

# Fixed and Operable Windows with Nail Fin Installation Guide

## InsightAL/InsightWD/I200A/I200W CityVu/CityLine/C600/C605/C700/C705 TimberVu/TimberLine/W600/W605/W700/W705

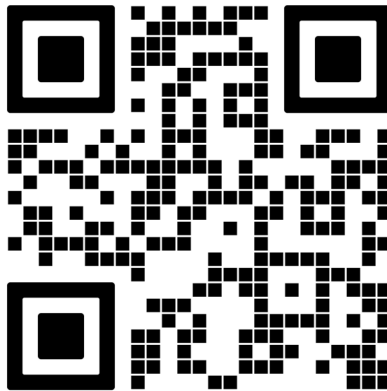

-Scan here for a digital version-

Part # IG-117 - V.1.0 3/13/2026

Pages 5 to 12 -- Weather Resistant Barrier (WRB) Application  
Pages 13 to 17 -- Liquid Barrier Application (LBA) Allowing Weeping at Sill  
Pages 18 to 22 -- Liquid Barrier Application (LBA) Not Allowing Weeping at Sill

If this set of instructions does not match your installation method or the wall conditions of the job site, please call Quaker Customer Service for additional information.



Quaker Window Products  
504 Highway 63 S  
Freeburg, MO 65035  
Phone: 800-347-0438  
Fax: 573-469-4151  
[www.quakerwindows.com](http://www.quakerwindows.com)

Note:

While the details within these instructions are based on the I200 Fixed configuration, the installation and sealing methods also apply for the other Operable and Operable/Fixed configurations.  
Some Wood and Aluminum Cladding is not shown for clarity.

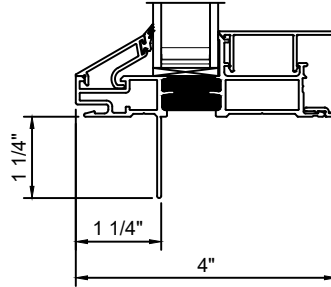

InsightAL/I200A

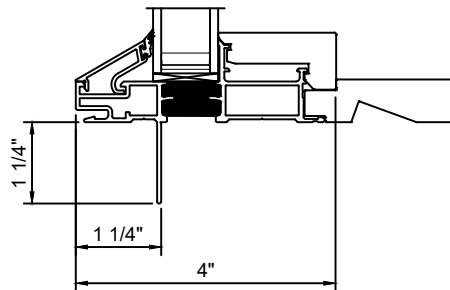

InsightWD/I200W

Fixed frames shown,  
but the following  
instructions will cover  
all frame options,  
including all  
operable windows.

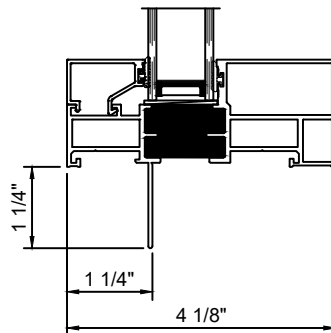

CityVu/CityLine/  
C600/C605/C700/C705

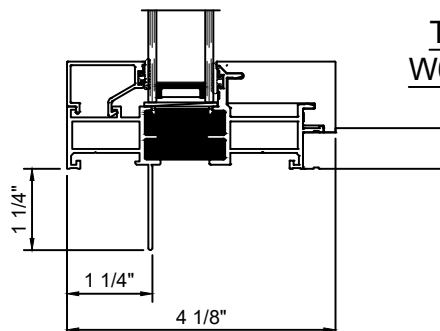

TimberVu/TimberLine/  
W600/W605/W700/W705

## Tools Required by Installer



## Materials Required by Installer



## **-Carefully read these instructions before starting any installation-**

Failure to install and maintain QUAKER® products according to these instructions may void any product warranty. However, these are generic instructions that cover common situations and applications, aspects of which may not be appropriate for all installations due to building design, site conditions, construction materials, or installation methods used. Refer to shop drawings, if applicable, for additional notes and details. Please consult Quaker for specific applications not covered in these installation instructions, or visit our website at [www.quakerwindows.com](http://www.quakerwindows.com), or call 800-347-0438 for additional information.

### Tools

- Follow manufacturer's instructions and safely operate tools, ladders, or scaffolding. Always wear safety glasses. Failure to do so could result in injury, product, or property damage.

### Handling

- Do not store QUAKER products outside or in an unprotected, high moisture, or high heat environment prior to installation. Doing so could result in product damage.
- Do not carry, transport, or store QUAKER products in a flat (horizontal) position. Doing so could result in product damage or injury.
- Window and door units should be kept or stored in an upright (vertical) position, with support across the sill to avoid bowing. Do not lay any units in a flat position!

### Glass

- If glass gets broken, please exercise caution, as glass fragments can cause lacerations or other injuries. In many areas, local building codes require safety glass to be used in certain applications. All QUAKER products are available with safety glass if they are ordered that way.

### Fastening

- Metal fasteners and components could corrode when used in contact with preservative-treated lumber. Use approved and appropriate fasteners and components to fasten QUAKER products in this application. Failure to do so could result in a product performance failure, injury, or property damage.
- Quaker does not provide anchorage or fastener calculations.
- Quaker is not responsible for determining structural adequacy of the anchorage and fasteners used to install QUAKER products, or the openings into which they are installed.

### Installation

- Report any damage to dealer immediately. Do not install product if damaged. Quaker is not responsible for addressing products that are damaged after delivery, or product that is installed in a damaged condition.
- Always support window or door products in an opening until fully fastened. Failure to do so could result in the product falling out of an opening and causing injury, product, or property damage.
- Nailing flanges and drip caps (integral or applied) do not take the place of window flashing. All QUAKER products must be properly flashed and sealed with material compatible sealant for protection against water and air infiltration around the entire exterior perimeter. Failure to do so could result in a product installation failure and property damage.
- Windows and doors must be properly shimmed. To properly shim a QUAKER product, follow relevant installation guidelines, and never set a window directly on a sill plate. Failure to shim properly is an installation failure that could result in product performance failure or property damage.
- Construction directly above an opening must be engineered and designed not to transfer loads directly to any windows or doors. If live or dead loads are transferred to a QUAKER product, this may affect functionality and result in glass failure or otherwise damage frame joinery, perimeter seals, or other aspects of the product. Proper construction of the rough opening must take place prior to the installation of the QUAKER product.
- Please confirm that any necessary vertical deflection of the head condition is consistent with the selected QUAKER product. Most QUAKER products are not designed to allow any deflection at the head condition. Shop drawings may indicate the maximum allowable vertical deflection at the head condition of a QUAKER product. If vertical deflection is a concern but shop drawings are not provided, please contact Quaker for assistance.
- Windows and doors have small parts that, if swallowed, could pose a choking hazard to young children. Please dispose of unused, loose, or easily removed small parts. Failure to do so could result in injury or death.
- Do not drill through or into the sill or frame of any QUAKER products, whether to install alarm wires or for any other reason.
- During installation and positioning of any window or door products with an aluminum frame, make sure to align the thermal break of the product, with the insulation plane or air barrier of the building itself, in order to maintain continuity and integrity of the thermal envelope, and prevent thermal bridging that leads to excessive thermal transfer and/or condensation. In other words, the thermal break of the product must be recessed from the exterior plane of the wall opening, remain fully embedded within the wall opening, and not be exposed directly to exterior elements.

## Sealing

- Follow supplier instructions for proper application of minimally expanding foam, sealant, water resistant barrier or liquid barrier, and flashing products and systems to ensure safety, proper material application, compatibility, and to understand the need for periodic maintenance for continued weather resistance of their products. Failure to do so could result in product performance failure or property damage.
- Minimally expanding foam insulation must be compliant with AAMA 812.
- If silicone is selected as an appropriate sealant, Quaker recommends using 100% neutral cure silicone sealant, that is ASTM C920 compliant. Always clean and prepare the surfaces where the sealant will be applied per the manufacturer's recommendation. Once applied, properly tool the sealant in place. Failure to do so could result in product performance failure or property damage.
- Flashing tape must meet ASTM-D779 performance requirements.
- Maintain and properly seal a minimum of 1/4" gap (or whatever is specified within these installation instructions or shop drawings) around the perimeter of the window or door frame and the exterior finish materials. Failure to do so could result in product installation failure or property damage.

## Joining

- Do not join any Quaker product to another product that is not designed for joining. Joined products must be individually supported in the opening. Failure to do so could affect operation and product performance and could result in a product installation failure or property damage.

## Cleaning

- Do not use any cleaning agent other than a mild, non-abrasive window washing solution or glass cleaner applied in accordance with any product labeling instructions and Quaker's care and maintenance instructions. The use of harsh chemicals (such as brickwash, bleach, alcohol, hydrochloric acid, or muriatic acid) for cleaning or other purposes may damage QUAKER products, glass, fasteners, hardware, seals, sealant, or metal flashing. Please protect these products by following the cleaning product's instructions for its proper use.
- Do not use a razor blade to clean a glass surface, as damage to the glass may result.

## IMPORTANT

- Buildings constructed prior to 1978 may contain lead paint which could be disturbed during window or door replacement. For more information on proper management of lead paint, go to: [www.epa.gov/lead](http://www.epa.gov/lead)
- Care must be taken to properly recycle or dispose of used or old materials. Any recyclable material should be separated from non-recyclable or hazardous materials. Please consult with local or state authorities regarding proper disposal of non-recyclable or hazardous materials.
- Inspect all window and door units for any damage or defects prior to installation. Contact the nearest QUAKER distributor if there are any problems or issues.
- **WARNING:** This product can expose you to chemicals, including titanium dioxide or methanol, which are known to the State of California to cause cancer and birth defects or other reproductive harm. For more information go to [www.P65Warnings.ca.gov](http://www.P65Warnings.ca.gov)
- **WARNING:** Drilling, sawing, sanding, or machining wood products can expose you to wood dust, a substance known to the State of California to cause cancer. Avoid inhaling wood dust or use a dust mask or other safeguards for your personal protection. For more information go to [www.P65Warnings.ca.gov](http://www.P65Warnings.ca.gov)
- When installation is completed, operable window and door products, and related hardware or equipment, may require some adjustments. Confirming operability and making minor adjustments are within the scope of the installation services performed by others.
- **WARNING - OVERHANG NEEDED:** It is recommended that doors (swing and sliding) with ADA or Low-Profile Sills be installed with an overhang depth equal in length to the height of the door. If you choose to use an overhang depth less than the height of the door, you must confirm that it is appropriate based on code requirements and the expected local wind and rain conditions.

# With Weather Resistant (WRB) Application (Pages 5-12)

--See FMA/AAMA 100-12 for additional information--

## WB1

From the interior, measure and verify the size of the rough opening. The rough opening should be  $\frac{3}{4}$ " wider and  $\frac{1}{2}$ " taller than the Window Unit, unless otherwise specified on the shop drawings. Verify the rough opening is flat, plumb, level, and square. Take diagonal measurements to check for square. The sill plate beneath the unit must be level for proper unit operation. Go to the exterior and cut the Weather-Resistant Barrier (WRB) in an 'I' pattern.

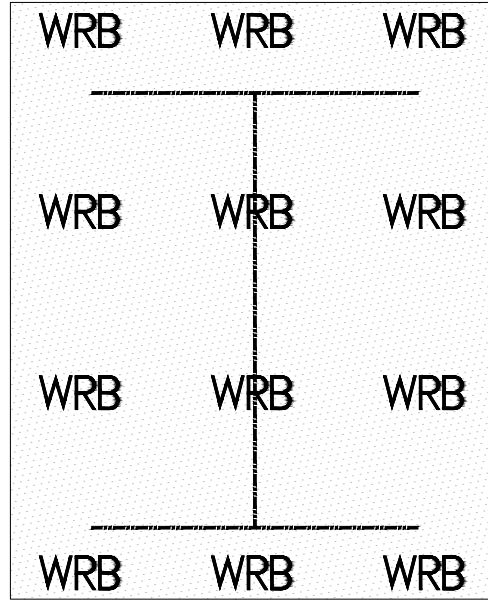
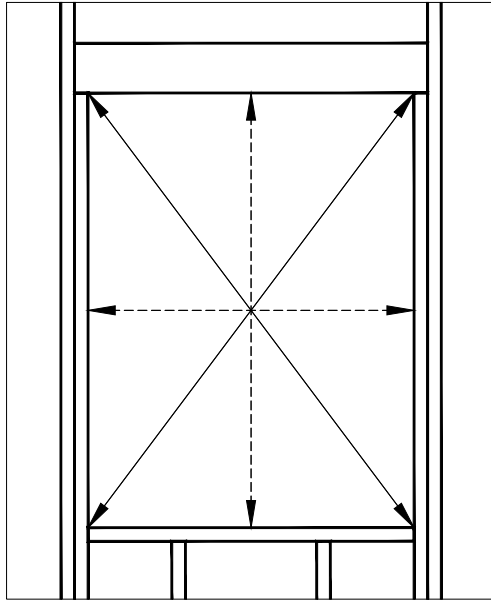

## WB2

Fold the WRB sides towards the interior and trim as needed. Do not staple in place. Make 4"-6" horizontal cuts in the WRB at the head and sill jambs. Make a 45° x 6" long cut at the head condition. Fold back WRB at the cut lines, and tape into place.

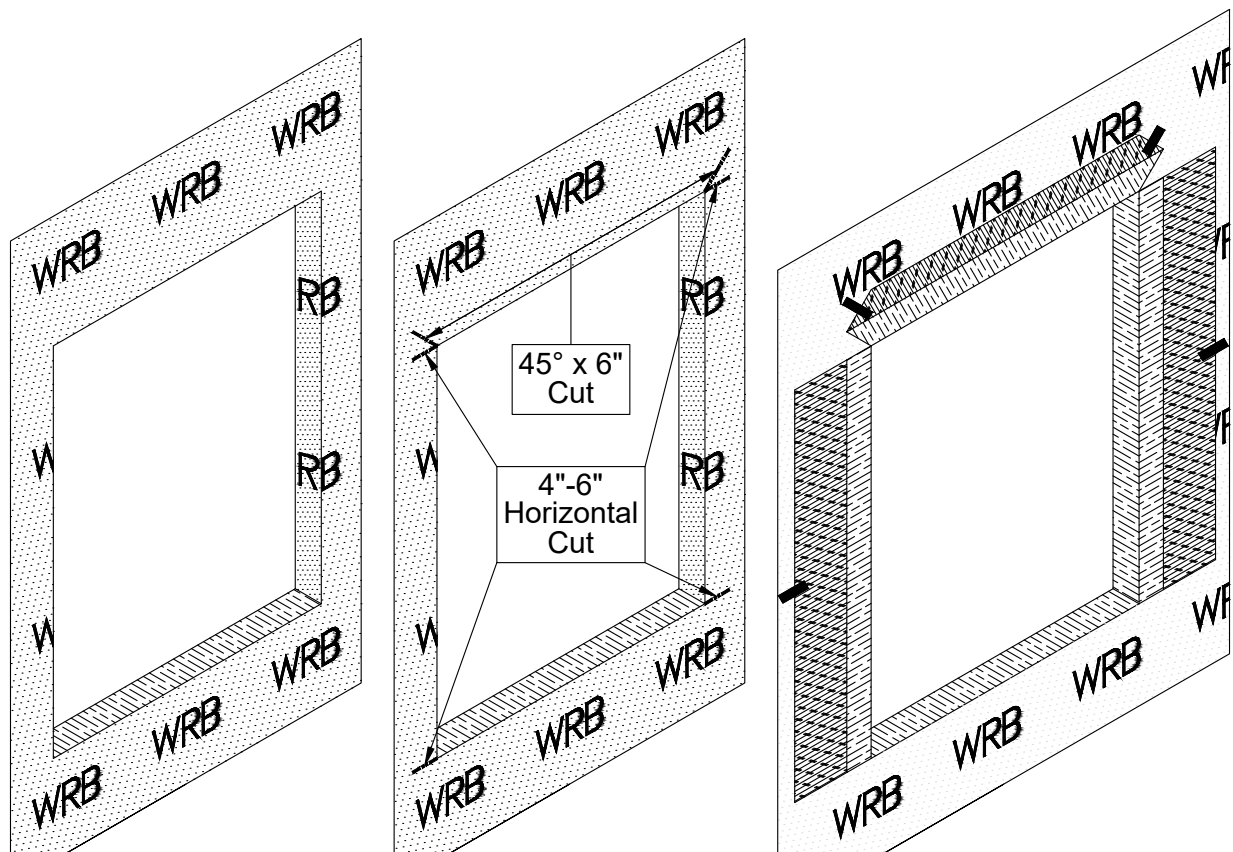

## WB3

Measure the width of the rough opening, and cut a length of self-adhering flashing that is 12", or more, than the width of the rough opening. This will allow the flashing to run 6"+ up each jamb condition. Apply the flashing to the exterior side first, allowing for a minimum of 3" below the sill and up each side. The flashing tape must cover the entire sill plate. If needed, apply an additional piece of flashing over the first one with a 1" minimum over-lap. Start from the exterior and work towards the interior. After applying the sill flashing, apply sealant at the jambs where shown. Fold the WRB jamb flaps back into place, over the sill flashing, and fix into place. Leave head flap in place.

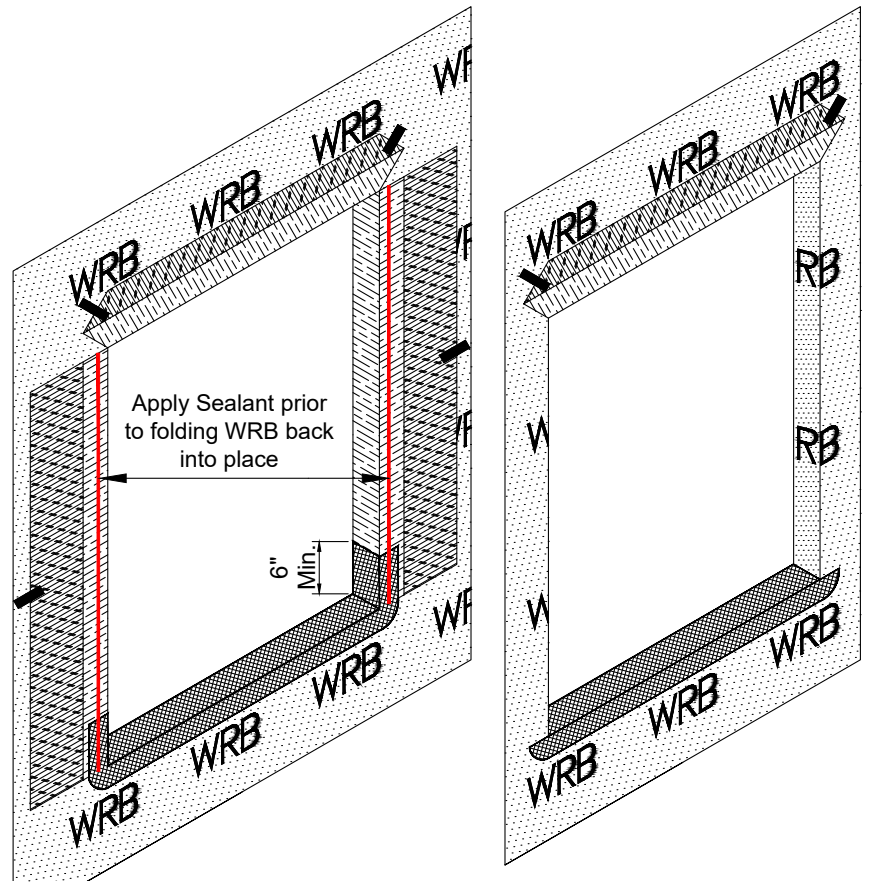

## WB4

Test fit the Window Unit in the opening to ensure proper fit. Make sure unit can be installed square, plumb, and level. Insert plastic shims at the sill and jambs. The unit will come with pre-punched holes for attachment. Match drill pilot holes in the structure per the Shop Drawings or anchorage calculations. Typically, 3" from the ends and 8" to 10" on center.

**NOTE:** Not all pre-punched holes will be used. When done, remove the unit.

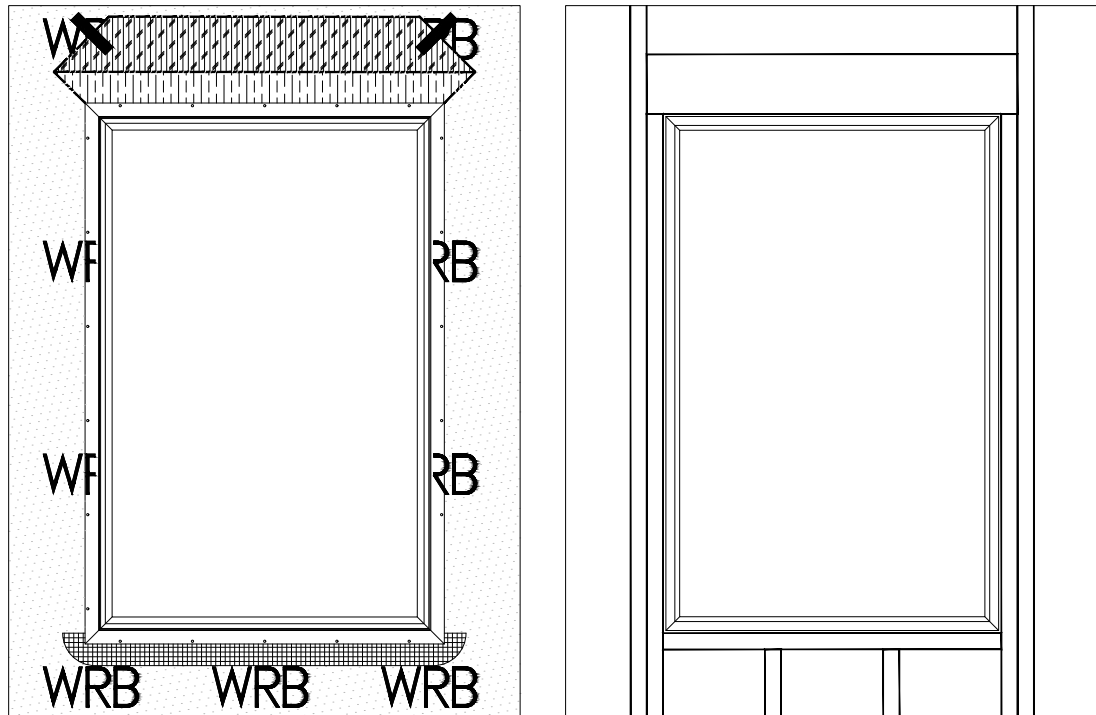

# WB5

## -THIS STEP REQUIRED ONLY WHEN WOOD INTERIOR TRIM IS FACTORY APPLIED-

Apply flashing tape (similar to the WRB flashing tape shown in Step WB3) to the underside of the wood trim and frame, and 6" up each jamb as shown below.

This step is required to be done by the installer.

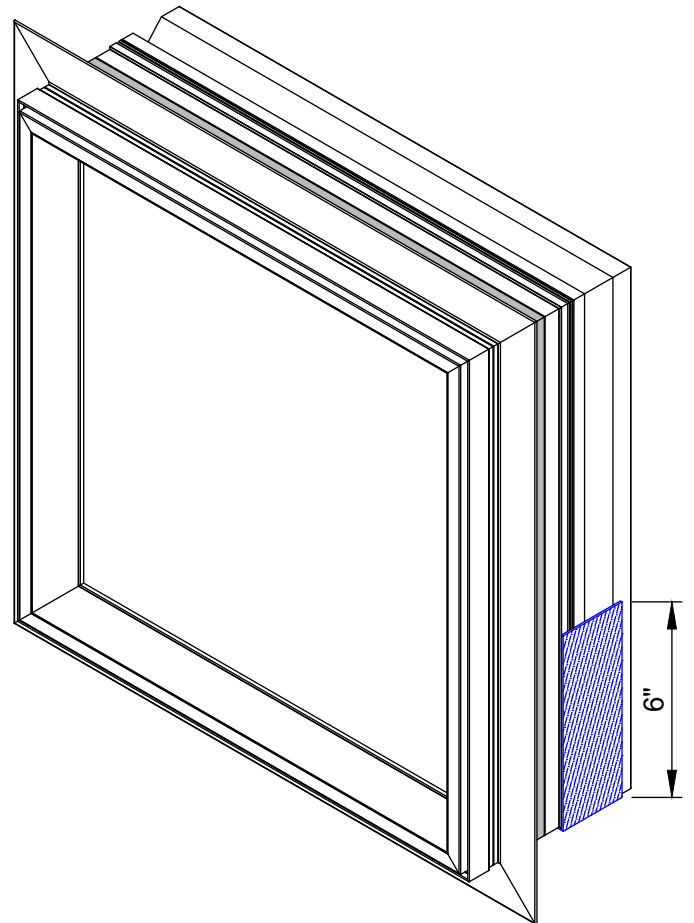
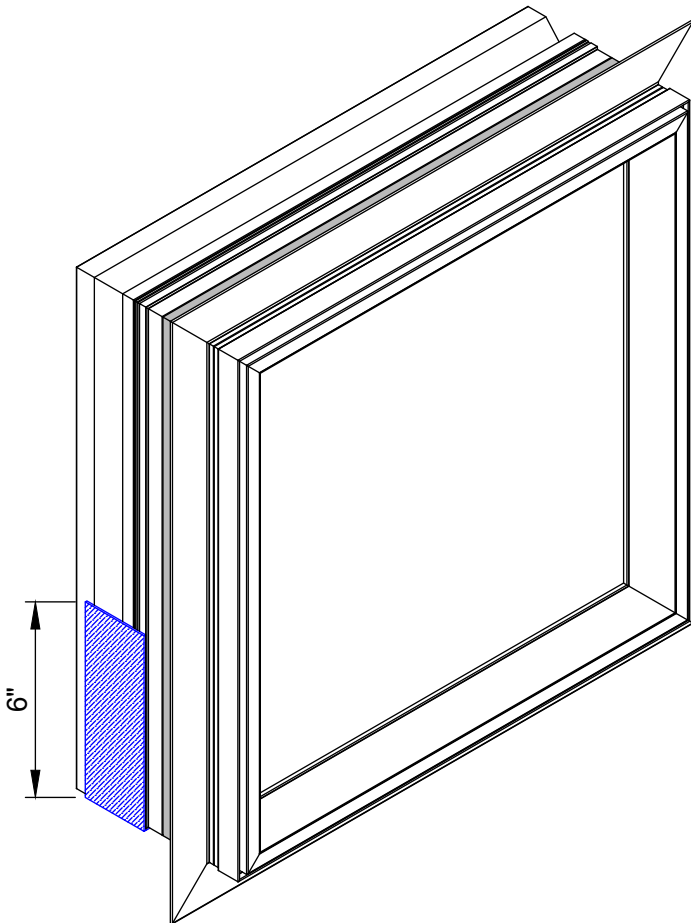
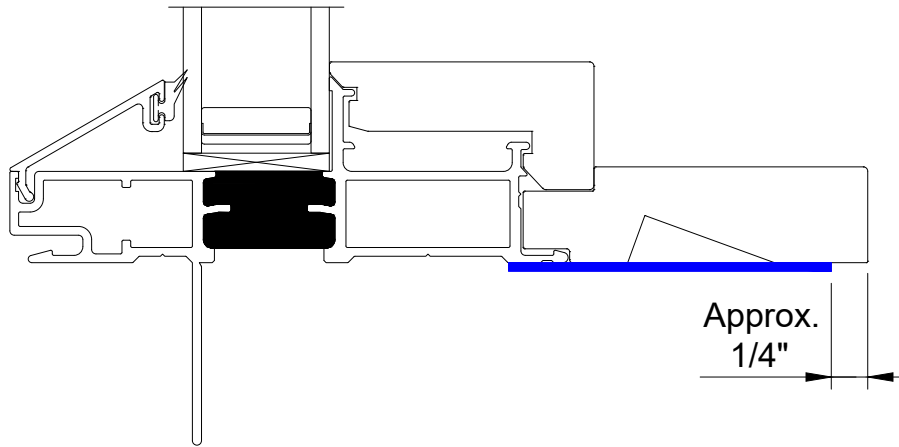

# WB6

Apply a generous amount of sealant around the entire Nail Fin as shown in the sketch, leaving (2) 2" voids no more than 4" from jambs at the sill. Make sure placement of sealant will contact the WRB and/or Flashing.

Also, apply sealant at the interior mitered Nail Fin corner joints.

**--WRB Supplier is required to specify what type of sealant should be used for compatibility--**

Re-Install the unit in the opening by pushing unit tight against the structure. Use plastic shims at the perimeter.

Make sure the unit is tight against the surrounding conditions, and is square, plumb, and level.

**DO NOT PLACE WINDOW UNIT DIRECTLY ON THE BUILDING STRUCTURE WITHOUT SHIMS.**

Use the appropriate fasteners to attach to the building structure.

DO NOT over-tighten the fasteners and check for level several times while fastening in place. Seal securely over all the fastener heads and at the exterior mitered Nail Fin corner joints.

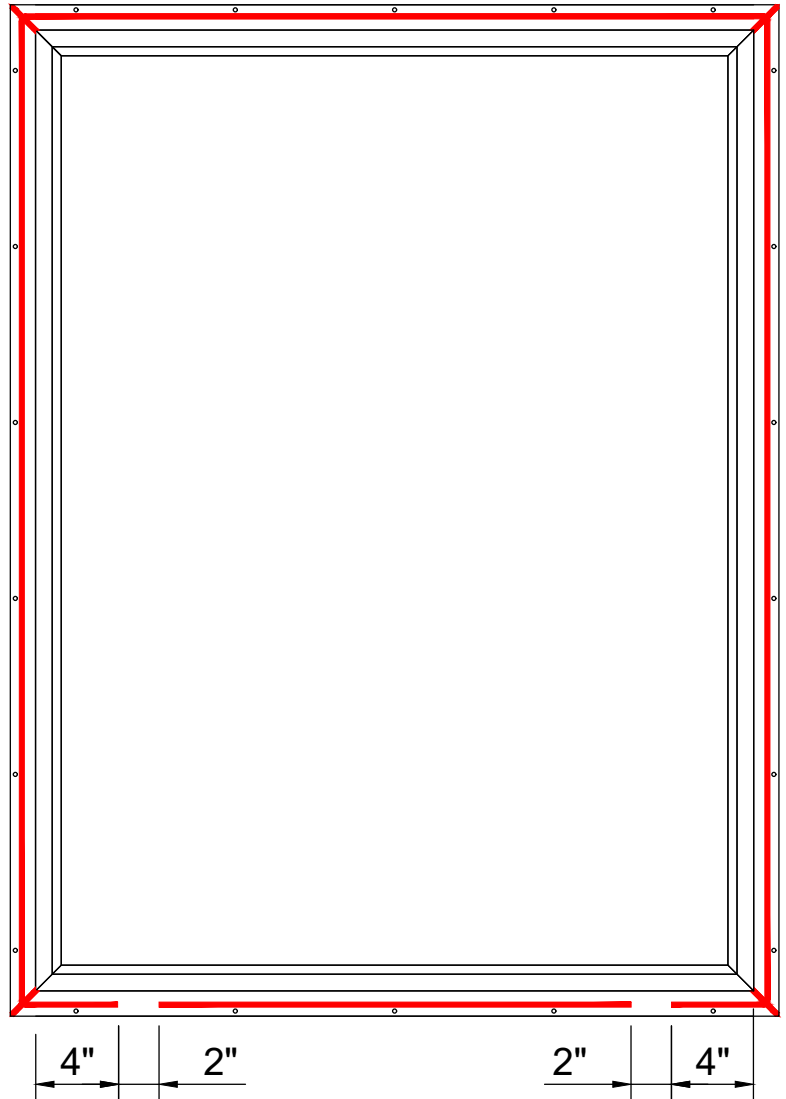
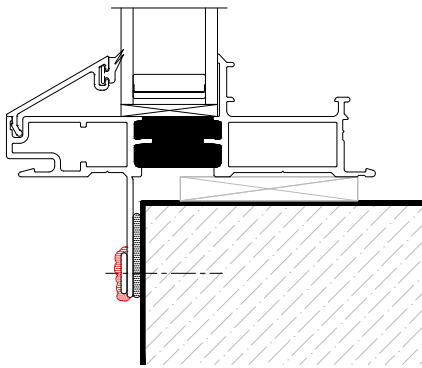
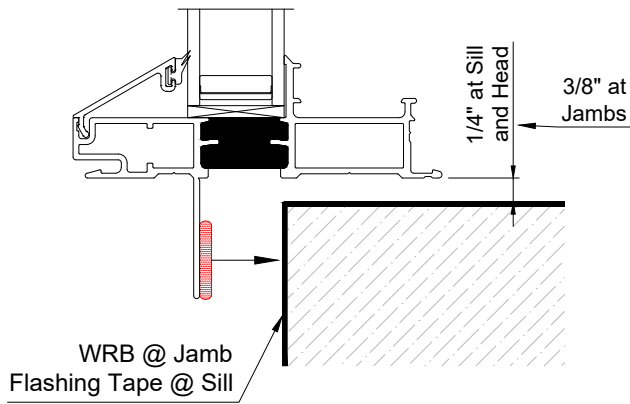

# WB7

**This step must be done for this application.**

If not already done, cut the Flashing to size. Ideally the Sill Flashing will extend past the facing of the building. Not extending the brake metal to the building face may cause water penetration to the interior, that Quaker Windows will not be responsible for. Apply sealant to the top and bottom of the Window Frame where shown, and set the Flashing into place and if required attach the flashing to building. Apply sealant over the fastener heads, then seal the top and sides of the Flashing to the building.

**DO NOT** seal the bottom of the Flashing at the sill.

Seal the gap between the Window Frame and the Flashing as shown below.

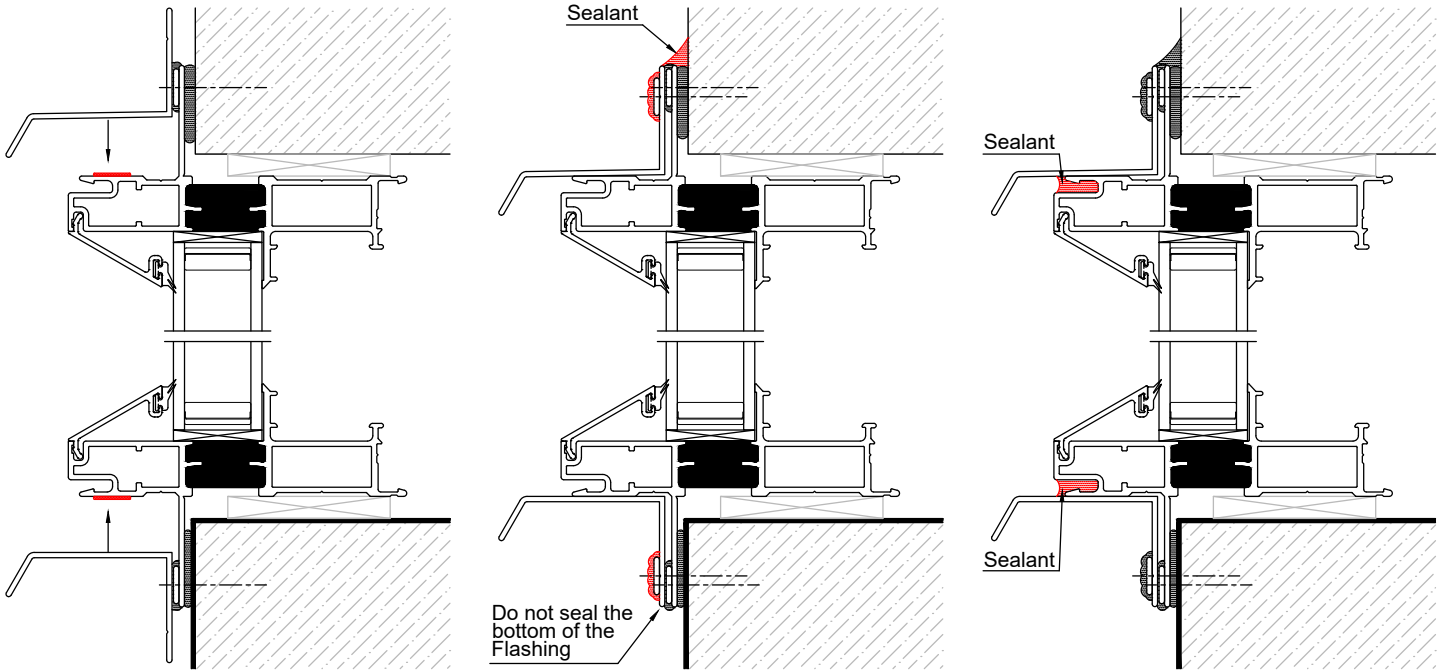

# WB8

Apply flashing tape at the sides of the window frame as shown. Extend tape a minimum of 1" past the Nail Fin, but not more than the width of the flashing tape. Smooth the tape using a J-Roller.

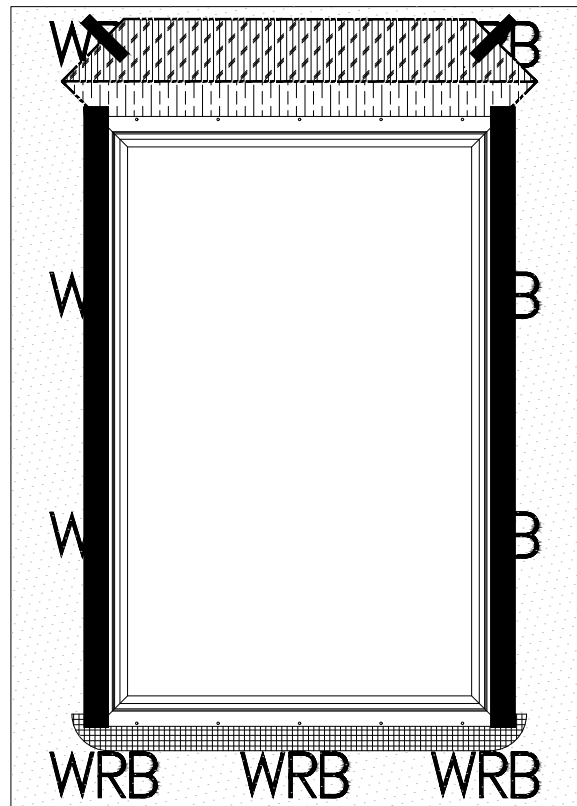

# WB9

Apply flashing tape at the top of the window frame as shown, overlapping the side flashing tape.  
Smooth the tape using a J-Roller.  
**Side flashing tape cannot extend above the top flashing tape. Doing so could result in product or property damage.**

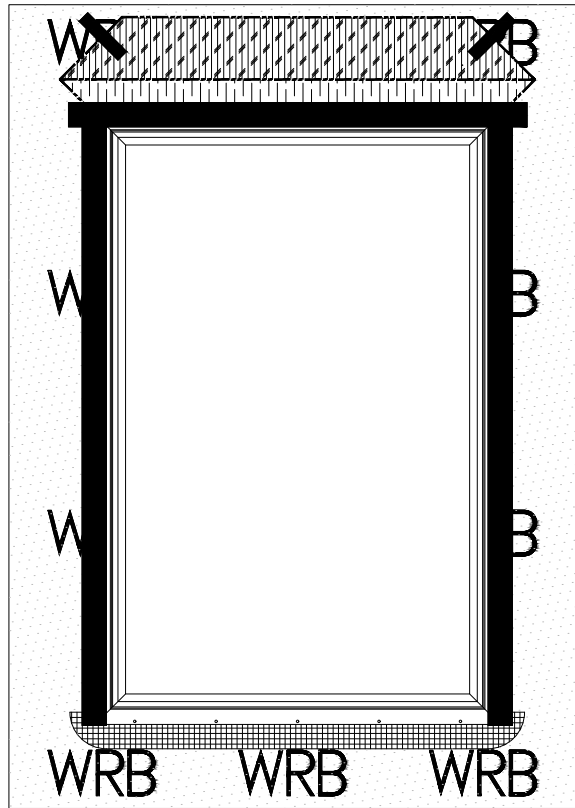

# WB10

Unfold the top flap of the wrap, and tape the angled seams as shown. Smooth the tape using a J-Roller.

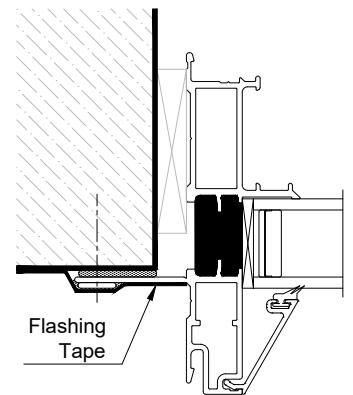
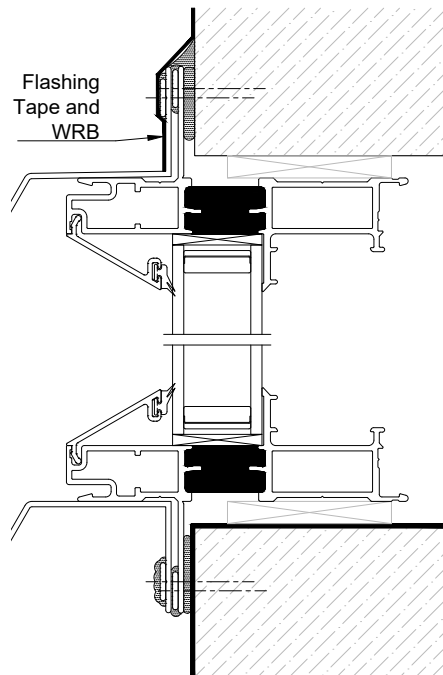
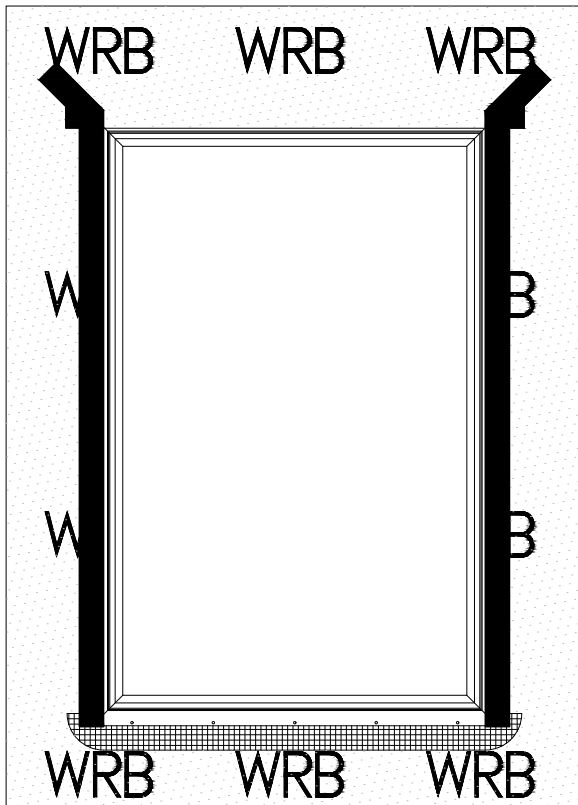

# WB11

Refer to the Shop Drawings if additional flashing or other material is required. After exterior building construction is completed, install backer rod, then apply a continuous bead of sealant around entire exterior perimeter of window frame and tool in place.

Note:

Installer to verify that Sealant being used is compatible with Quaker window frame and the surrounding building construction materials.

Note:

Please inform the exterior facade installer that they must maintain a minimum 1/4" gap between the facade material and the Window Unit, and that the facade material should never come in contact with the Window Unit.

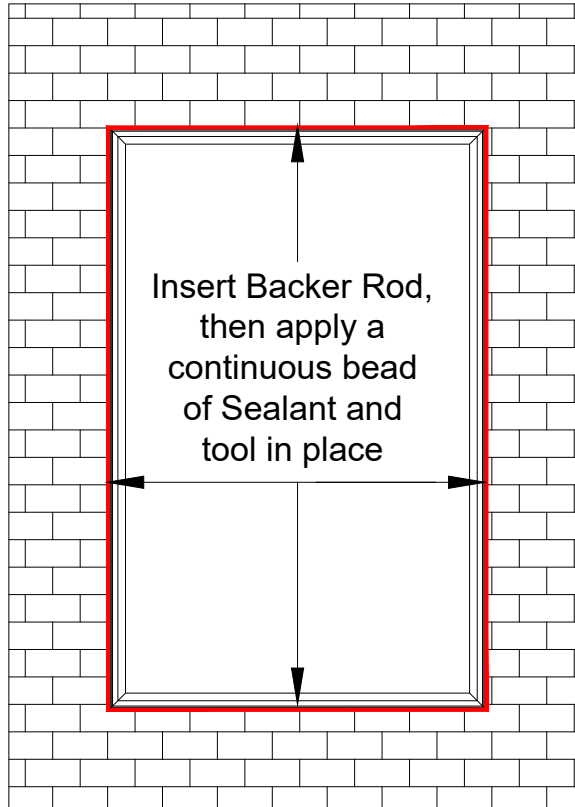

## This step must be done for this application.

At the interior head and jambs, insert insulation between the frame and the building conditions (no insulation at the sill). Install a backer rod, then apply a continuous bead of sealant around the entire interior perimeter of the window frame. Tool sealant in place as needed.

If Extension Jambs are used/required, refer to Instruction IG-118.

### Note:

Installer to verify that Sealant being used is compatible with Quaker window frame and the surrounding building construction materials.

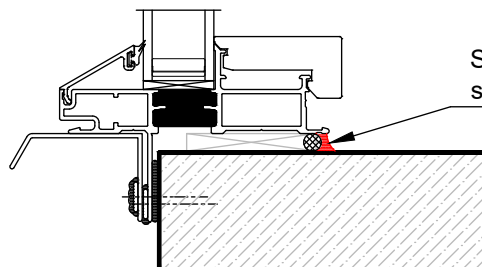
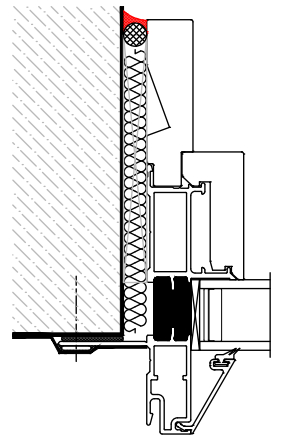
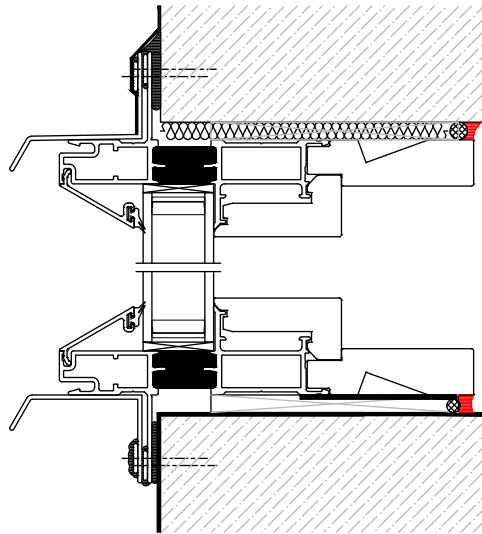
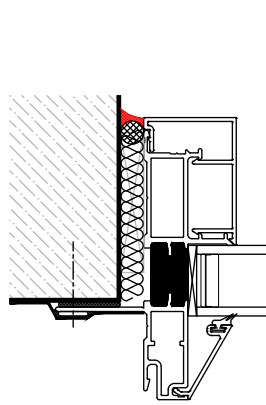
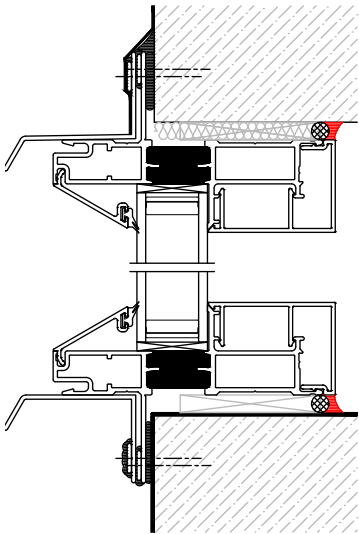
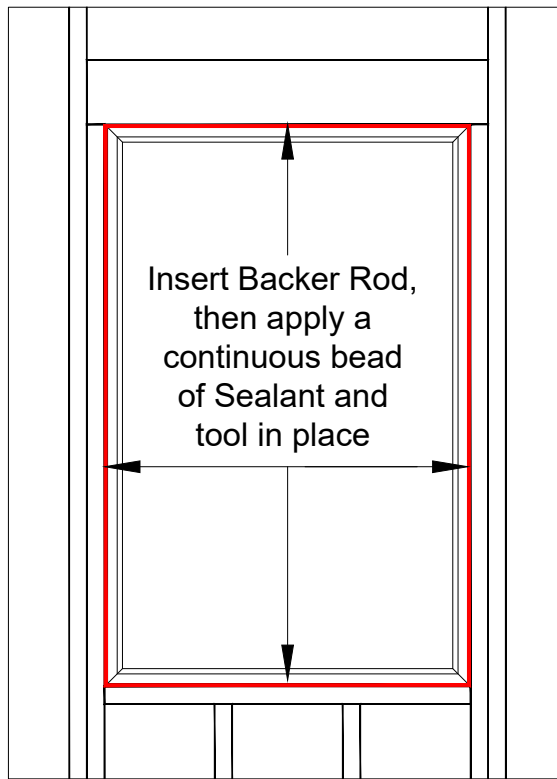

Seal here when Extension Jambs are shipped loose or are 'By Others'

**This Completes the Installation when a Weather Resistant Barrier is being used**

# Liquid Barrier Application (LBA) ALLOWING Sill Weeping (Pages 13-17)

## LB1

After the initial LBA has been applied, from the interior measure and verify the size of the rough opening. The rough opening should be  $3/4$ " wider and  $1/2$ " taller than the Window Unit, unless otherwise specified on the shop drawings. Verify the rough opening is flat, plumb, level, and square. Take diagonal measurements to check for square. The sill plate beneath the unit must be level for proper unit operation.

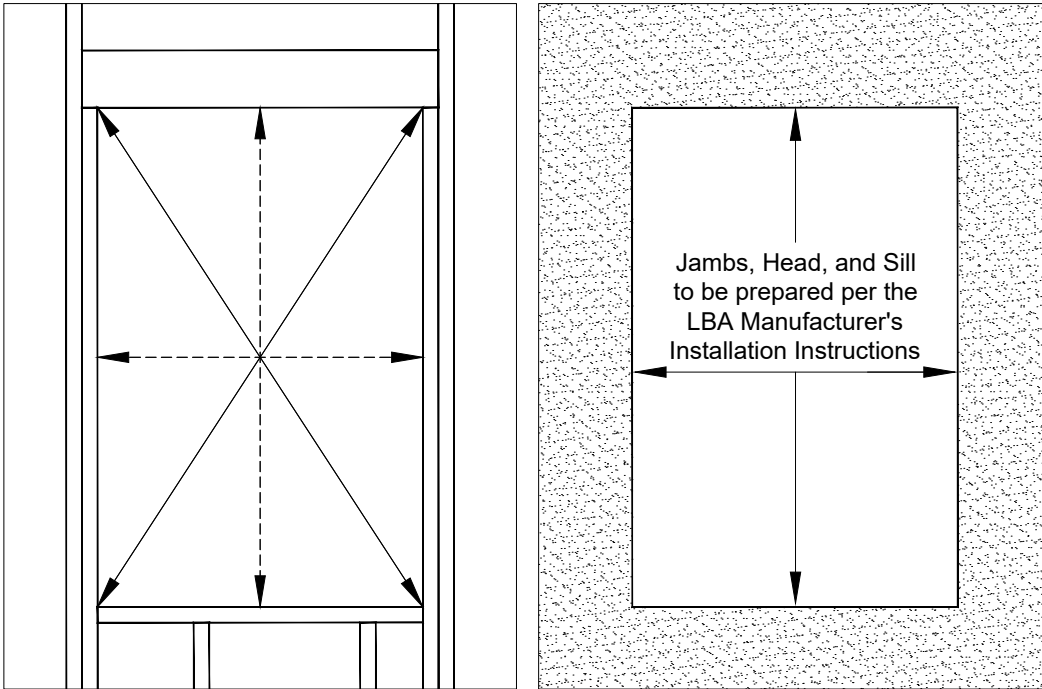

## LB2

Test fit the Window Unit in the opening to ensure proper fit. Make sure unit can be installed square, plumb, and level. Insert plastic shims at the sill and jambs. The unit will come with pre-punched holes for attachment. Match drill pilot holes in the structure per the Shop Drawings or anchorage calculations.

Typically, 3" from the ends and 12" on center.

**NOTE:** Not all pre-punched holes will be used. When done, remove the unit.

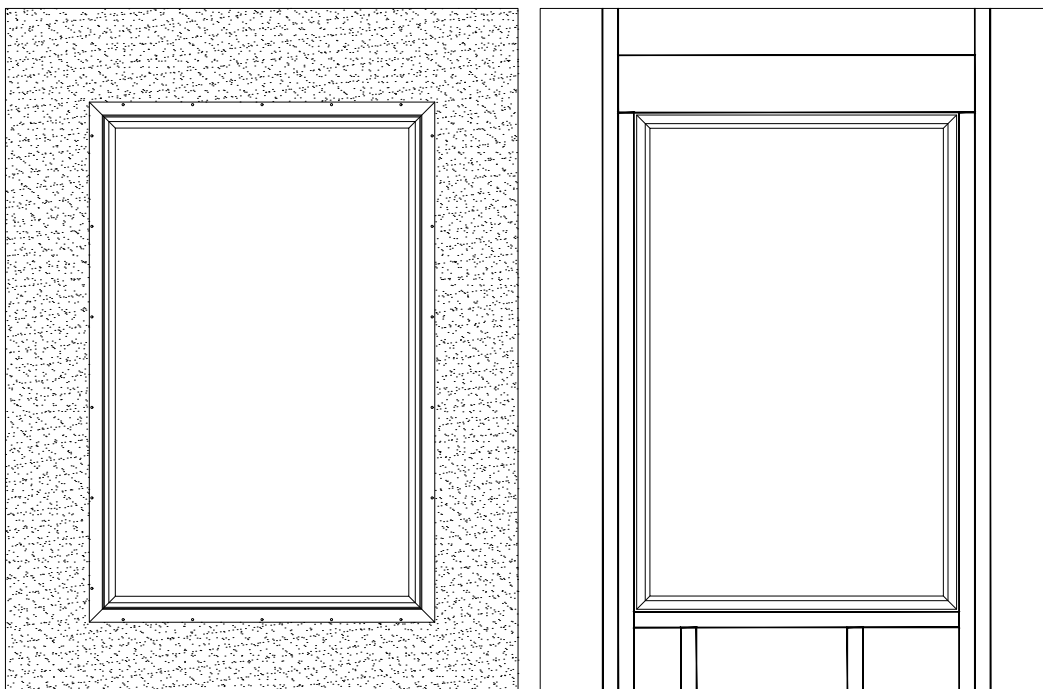

**-Before proceeding refer to Step WB5 on Page 7-**

Apply a generous amount of sealant around the entire Nail Fin as shown in the sketch, leaving (2) 2" voids no more than 4" from jambs at the sill. Make sure placement of sealant will contact the WRB and/or Flashing.

Also, apply sealant at the interior mitered Nail Fin corner joints.

**-WRB Supplier is required to specify what type of sealant should be used for compatibility--**

Re-Install the unit in the opening by pushing unit tight against the structure. Use plastic shims at the perimeter.

Make sure the unit is tight against the surrounding conditions, and is square, plumb, and level.

**DO NOT PLACE WINDOW UNIT DIRECTLY ON THE BUILDING STRUCTURE WITHOUT SHIMS.**

Use the appropriate fasteners to attach to the building structure.

DO NOT over-tighten the fasteners and check for level several times while fastening in place. Seal securely over all the fastener heads and at the exterior mitered Nail Fin corner joints.

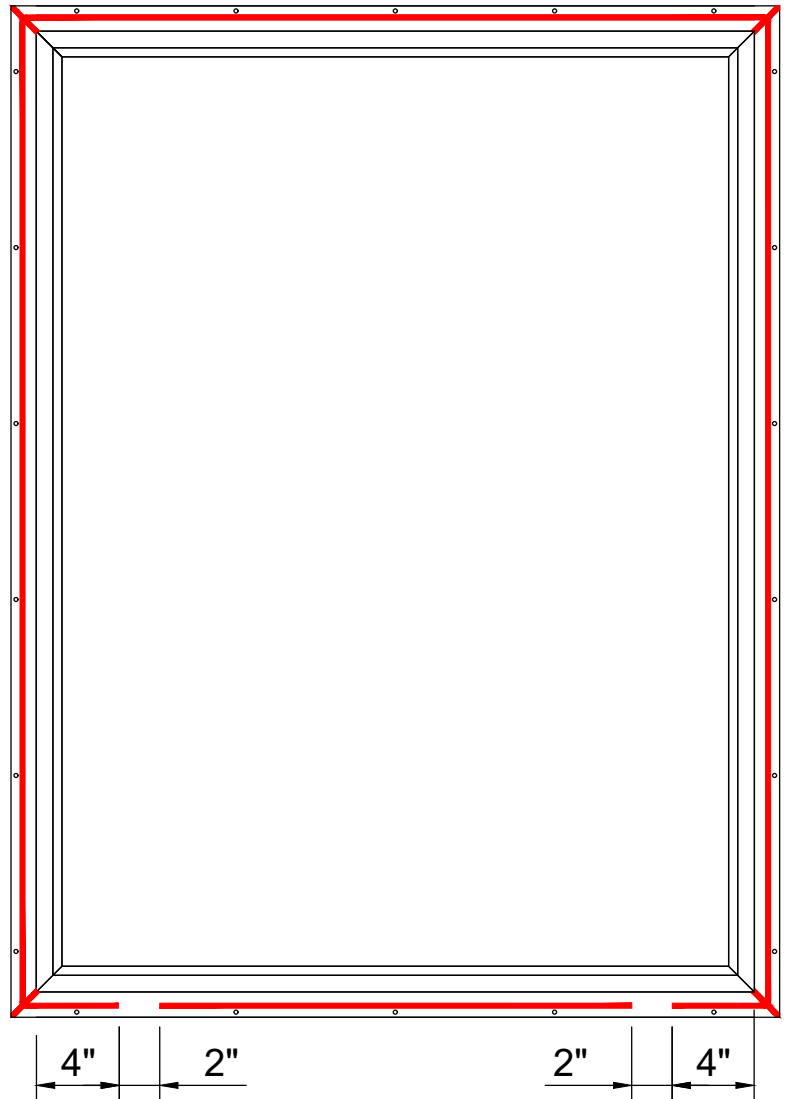
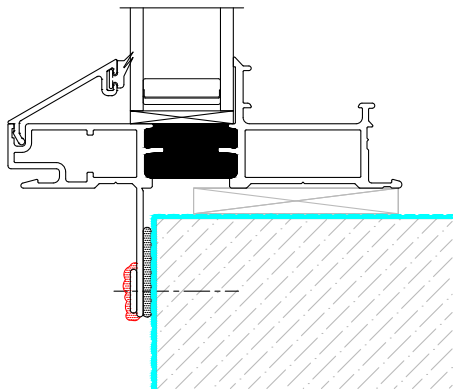
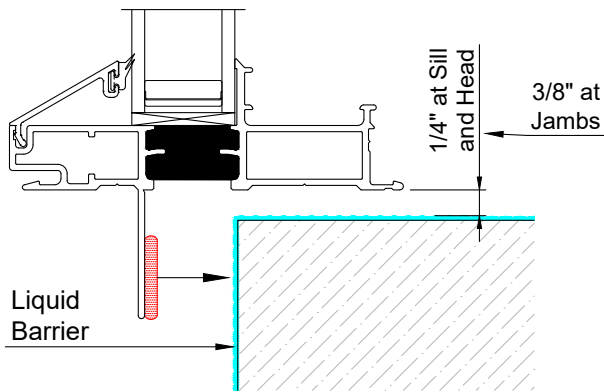

# LB4

**This step must be done for this application.**

If not already done, cut the Flashing to size. Ideally the Sill Flashing will extend past the facing of the building. Not extending the brake metal to the building face may cause water penetration to the interior, that Quaker Windows will not be responsible for. Apply sealant to the top and bottom of the Window Frame where shown, and set the Flashing into place and if required attach the flashing to building. Apply sealant over the fastener heads, then seal the top and sides of the Flashing to the building.

**DO NOT** seal the bottom of the Flashing at the sill.

Seal the gap between the Window Frame and the Flashing as shown below.

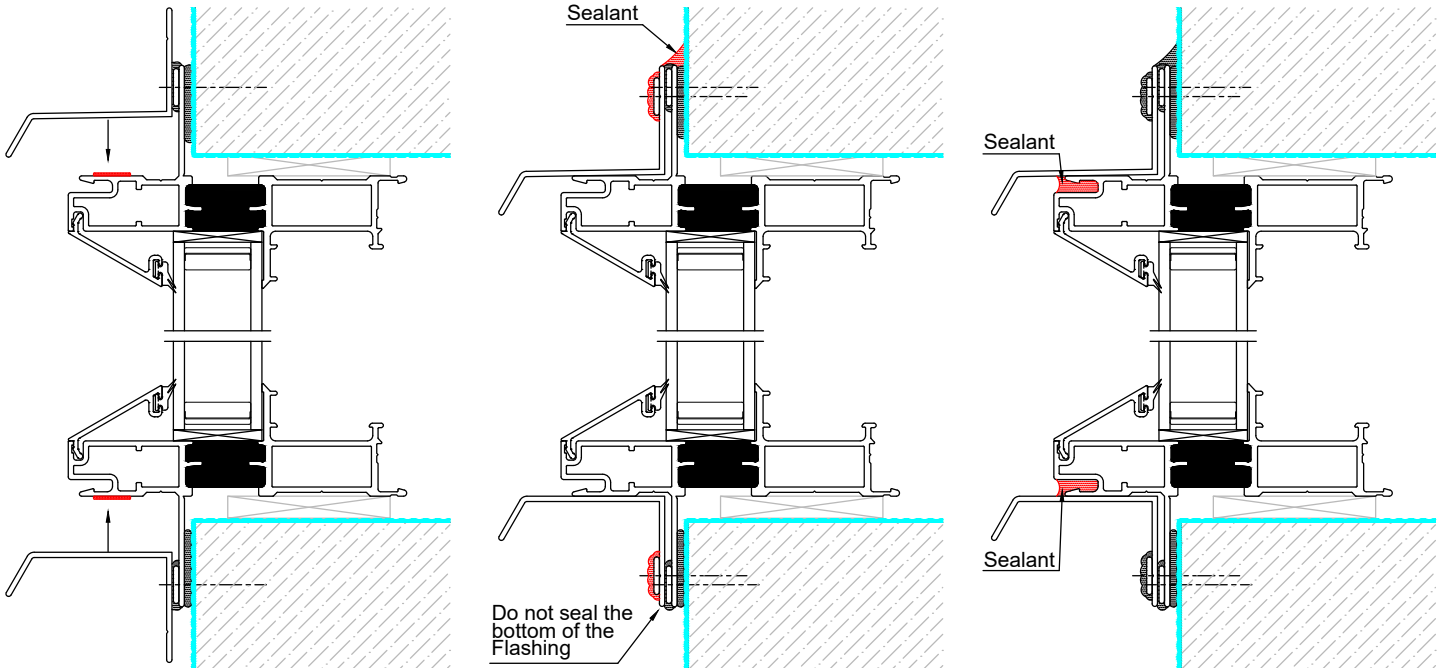

# LB5

Apply a Liquid Barrier over the Nail Fins and perimeter fasteners at the sill, head, and jambs. Liquid Barrier must be continuous and cover entire face as shown without any gaps or holes. At the interior head and jambs, insert insulation between the frame and the building conditions (no insulation at the sill).

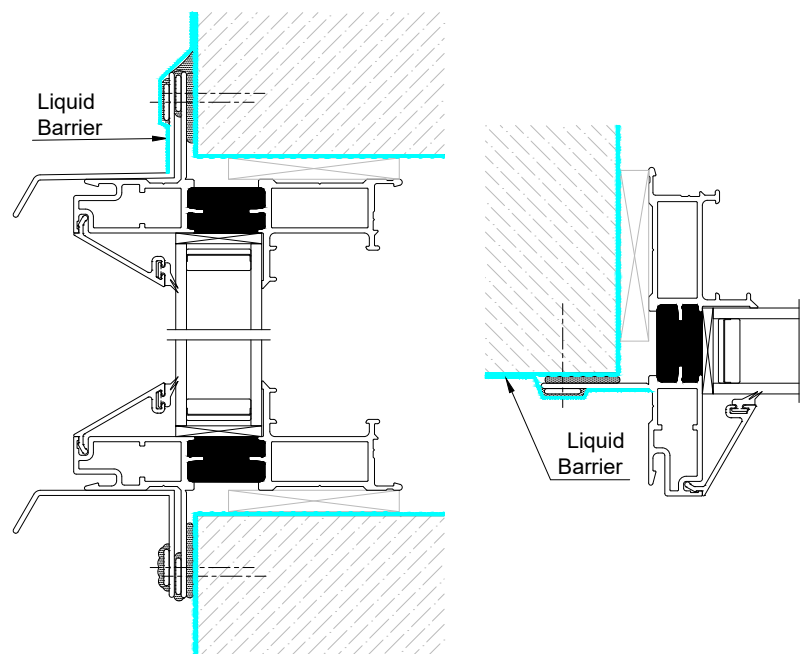
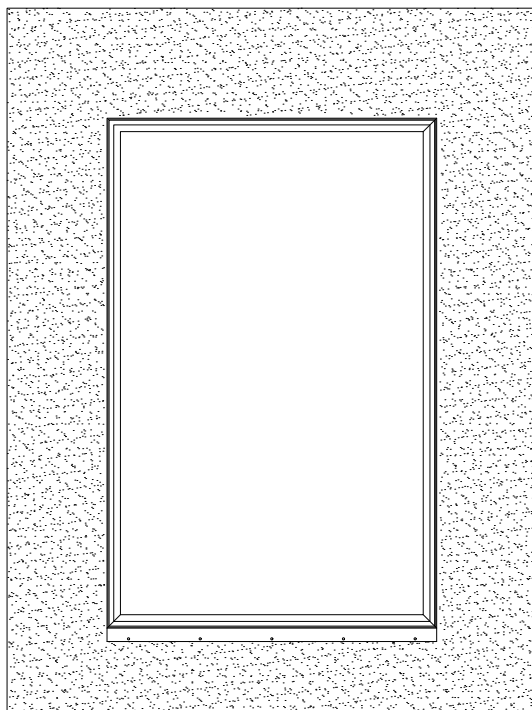

# LB6

Refer to the Shop Drawings if additional flashing or other material is required. After exterior building construction is completed, install backer rod, then apply a continuous bead of sealant around entire exterior perimeter of window frame and tool in place.

Note:

Installer to verify that Sealant being used is compatible with Quaker window frame and the surrounding building construction materials.

Note:

Please inform the exterior facade installer that they must maintain a minimum 1/4" gap between the facade material and the Window Unit, and that the facade material should never come in contact with the Window Unit.

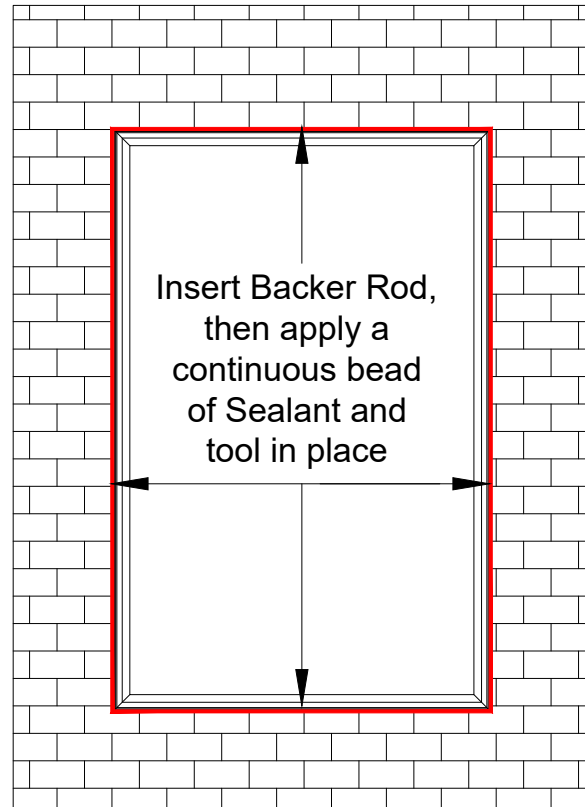

# LB7

**This step must be done for this application.**

At the interior head and jambs, insert insulation between the frame and the building conditions (no insulation at the sill). Install a backer rod, then apply a continuous bead of sealant around the entire interior perimeter of the window frame. Tool sealant in place as needed.

If Extension Jambs are used/required, refer to Instruction IG-118. Install a backer rod and apply a continuous bead of sealant around the entire perimeter.

Note:

Installer to verify that Sealant being used is compatible with Quaker window frame and the surrounding building construction materials.

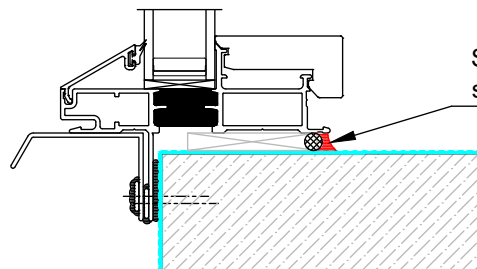
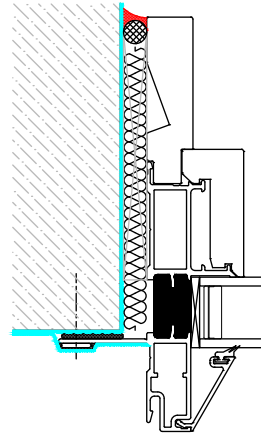
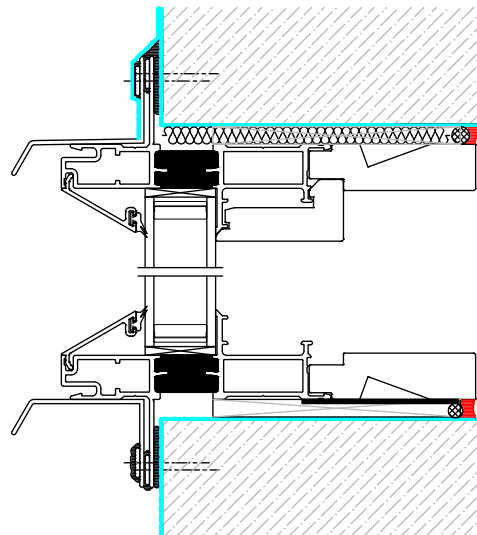
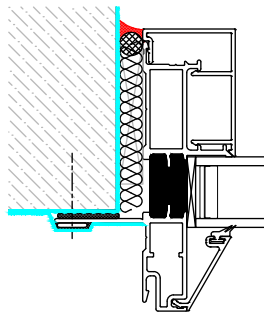
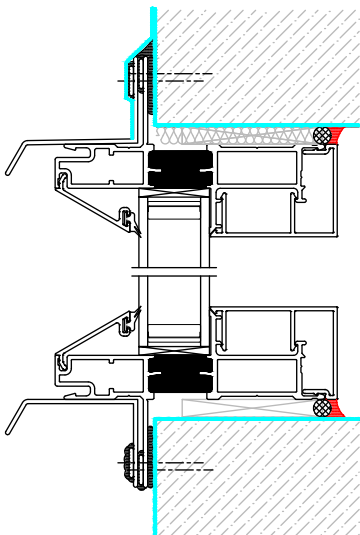
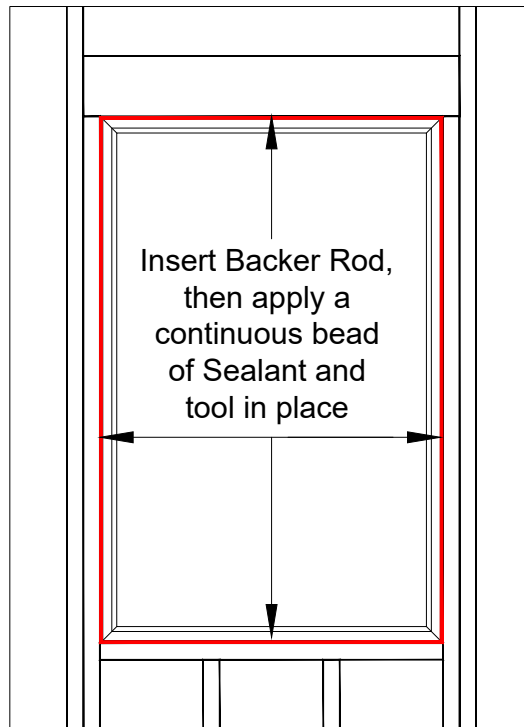

Seal here when Extension Jambs are shipped loose or are 'By Others'

**This Completes the Installation when a Liquid Barrier Application (LBA)  
ALLOWING Sill Weeping is being used**

# Liquid Barrier Application (LBA) NOT ALLOWING Sill Weeping (Pages 18-22)

## LBN1

After the initial LBA has been applied, from the interior measure and verify the size of the rough opening. The rough opening should be  $\frac{3}{4}$ " wider and  $\frac{1}{2}$ " taller than the Window Unit, unless otherwise specified on the shop drawings. Verify the rough opening is flat, plumb, level, and square. Take diagonal measurements to check for square. The sill plate beneath the unit must be level for proper unit operation.

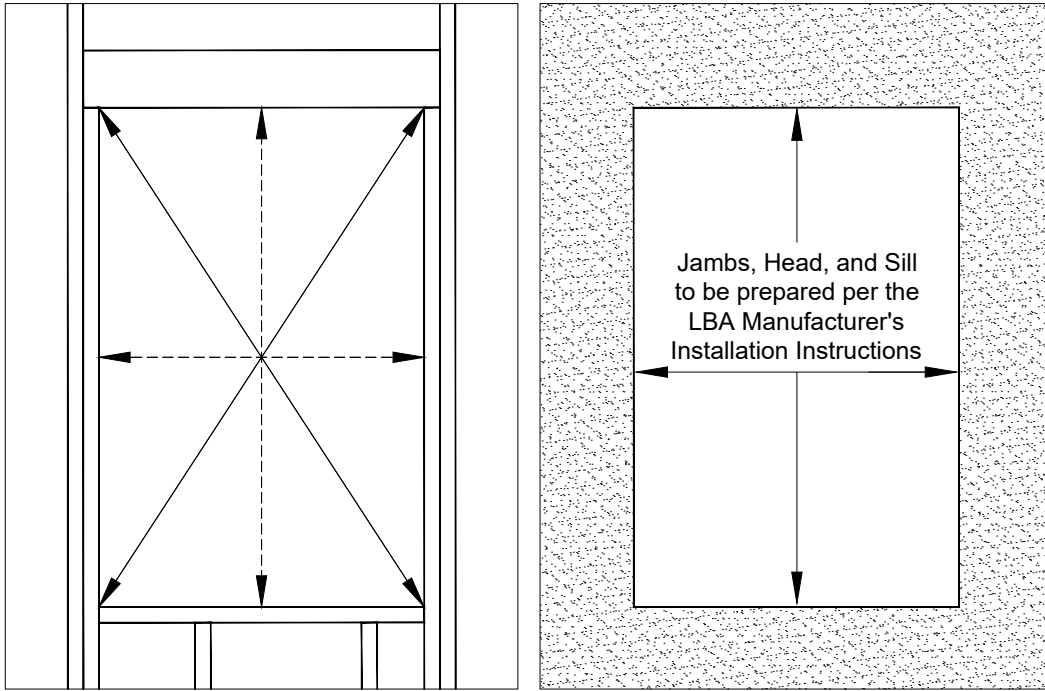

## LBN2

Test fit the Window Unit in the opening to ensure proper fit. Make sure unit can be installed square, plumb, and level. Insert plastic shims at the sill and jambs. The unit will come with pre-punched holes for attachment. Match drill pilot holes in the structure per the Shop Drawings or anchorage calculations.

Typically, 3" from the ends and 12" on center.

**NOTE:** Not all pre-punched holes will be used. When done, remove the unit.

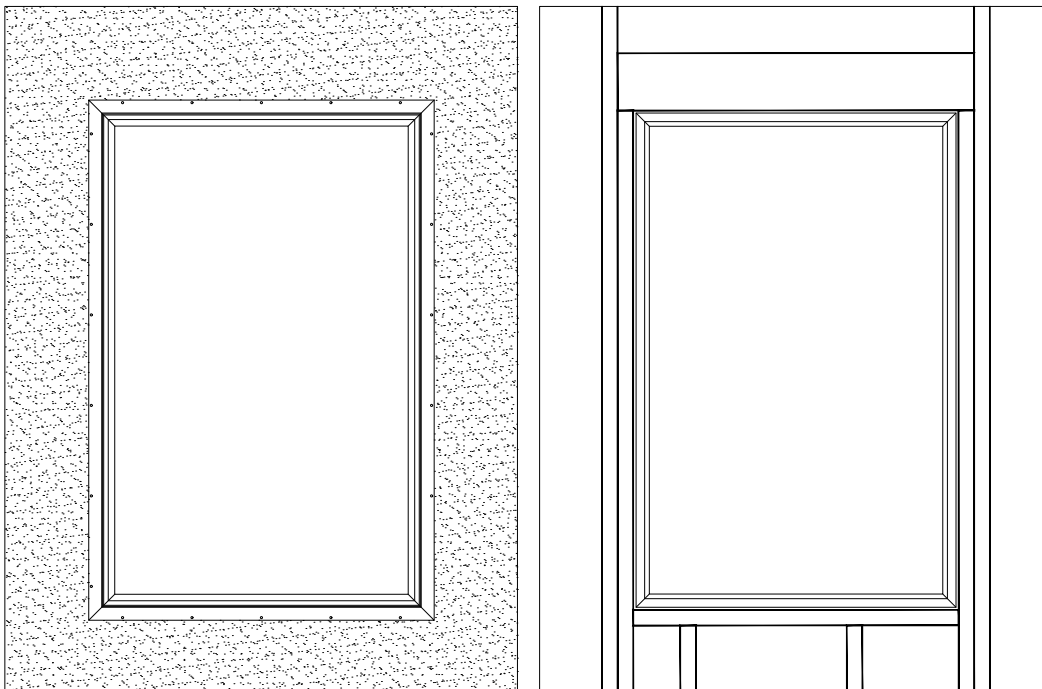

## -Before proceeding refer to Step WB5 on Page 7-

Apply a generous amount of sealant around the entire Nail Fin as shown in the sketch.

Make sure placement of sealant will contact the WRB and/or Flashing.

Also, apply sealant at the interior mitered Nail Fin corner joints.

## -WRB Supplier is required to specify what type of sealant should be used for compatibility-

Re-Install the unit in the opening by pushing unit tight against the structure. Use plastic shims at the perimeter.

Make sure the unit is tight against the surrounding conditions, and is square, plumb, and level.

## DO NOT PLACE WINDOW UNIT DIRECTLY ON THE BUILDING STRUCTURE WITHOUT SHIMS.

Use the appropriate fasteners to attach to the building structure.

DO NOT over-tighten the fasteners and check for level several times while fastening in place. Seal securely over all the fastener heads and at the exterior mitered Nail Fin corner joints.

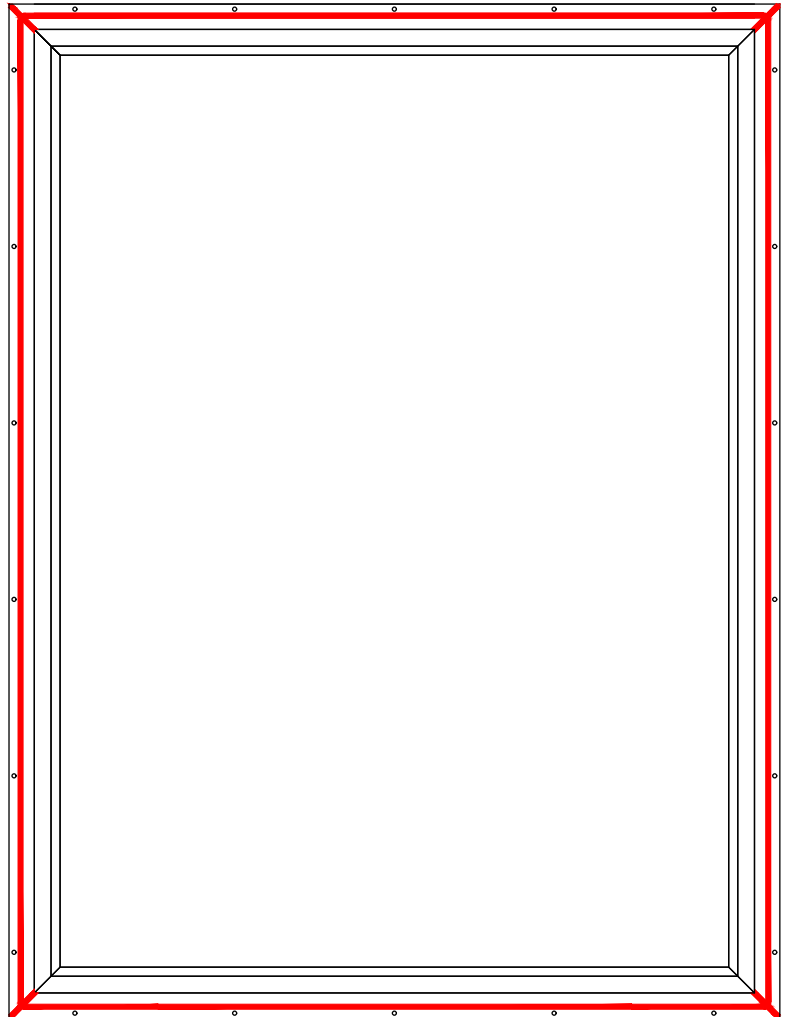
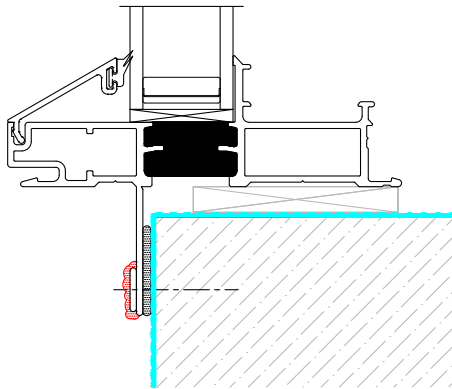
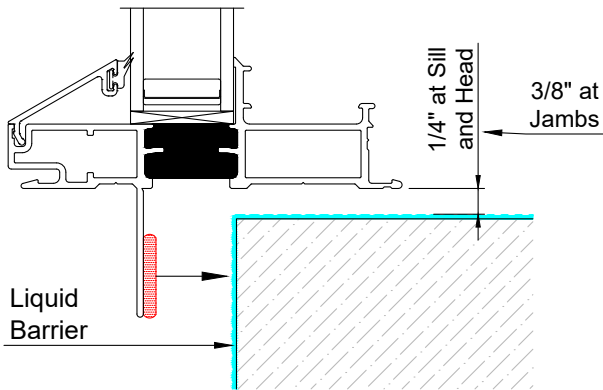

# LBN4

Apply a Liquid Barrier over the Nail Fins and perimeter fasteners at the sill, head, and jambs only.

Liquid Barrier must be continuous and cover entire face as shown without any gaps or holes.

**DO NOT APPLY THE LIQUID BARRIER OVER THE NAIL FIN AT THE SILL.**

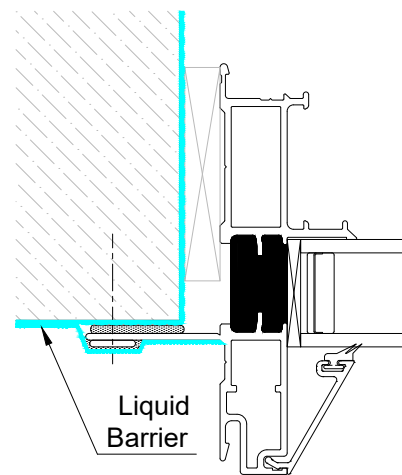
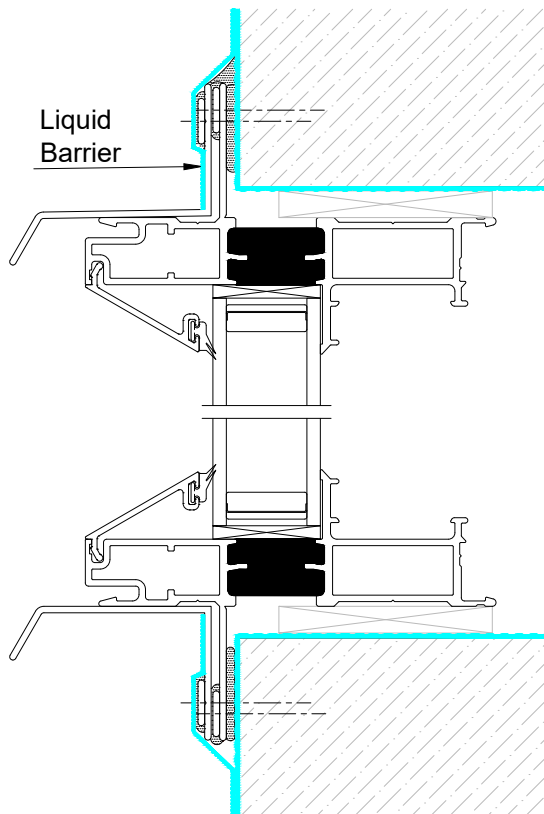
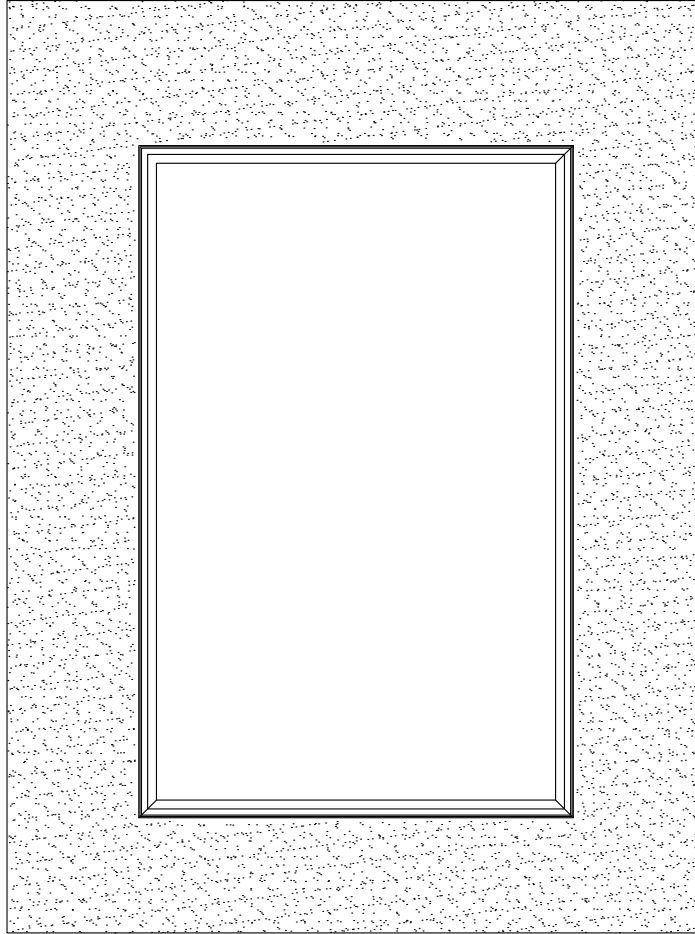

# LBN5

Refer to the Shop Drawings if additional flashing or other material is required. After exterior building construction is completed, install backer rod, then apply a continuous bead of sealant around entire exterior perimeter of window frame and tool in place.

Note:

Installer to verify that Sealant being used is compatible with Quaker window frame and the surrounding building construction materials.

Note:

Please inform the exterior facade installer that they must maintain a minimum 1/4" gap between the facade material and the Window Unit, and that the facade material should never come in contact with the Window Unit.

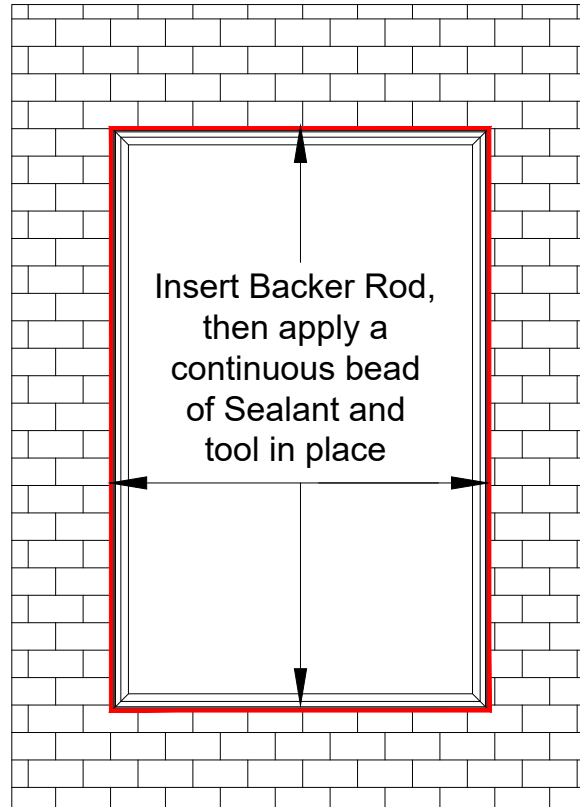

# LBN6

At the interior head and jambs, insert insulation between the frame and the building conditions (no insulation at the sill). Install a backer rod, then apply a continuous bead of sealant around the entire interior perimeter of the window frame. Tool sealant in place as needed. If Extension Jambs are used/required, refer to Instruction IG-118. Install a backer rod and apply a continuous bead of sealant around the entire perimeter.

Note:

Installer to verify that Sealant being used is compatible with Quaker window frame and the surrounding building construction materials.

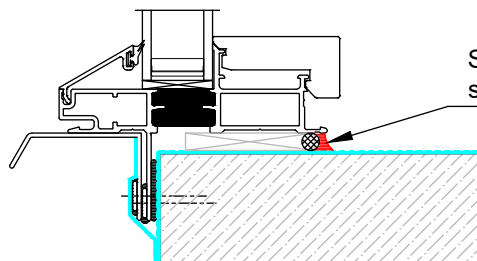
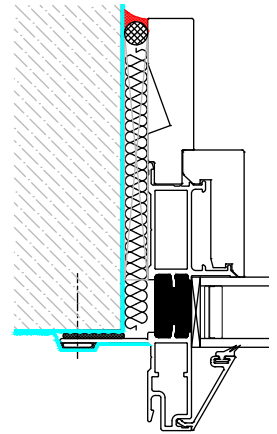
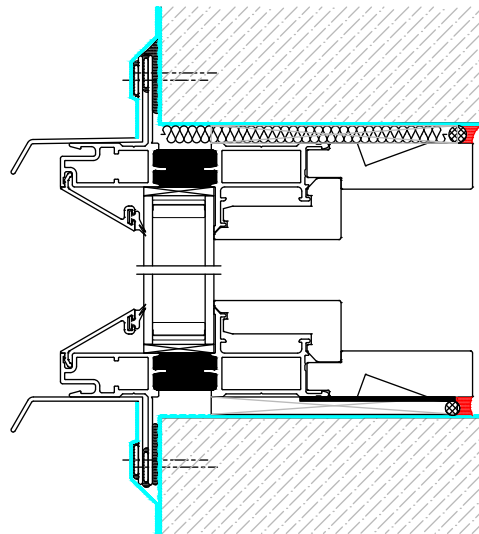
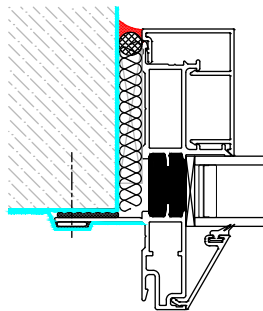
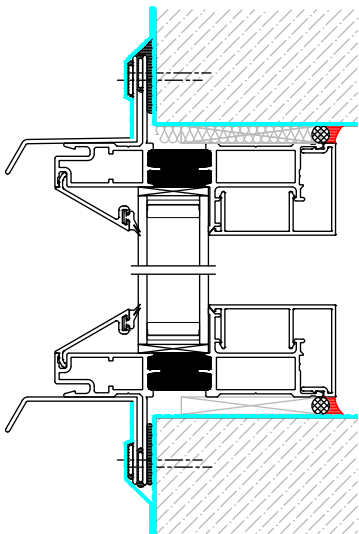
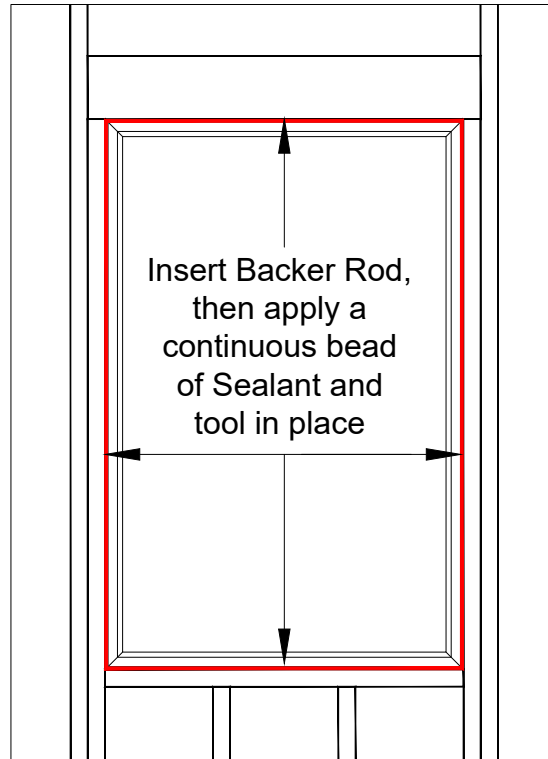

Seal here when Extension Jambs are shipped loose or are 'By Others'

**This Completes the Installation when a Liquid Barrier Application (LBA)  
NOT ALLOWING Sill Weeping is being used**