

# V300 Outswing Door with Standard Sill and Sidelite with Flashing Flange Installation Guide

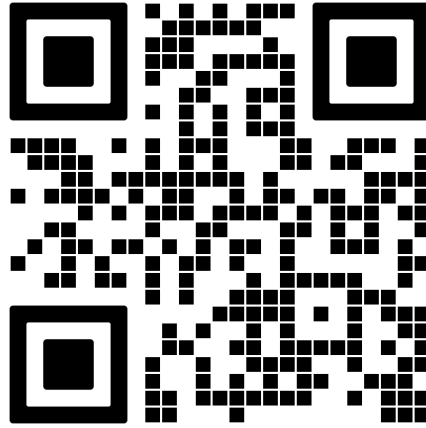

-Scan here for a digital version-

Part # IG-104 - V.1.4 4/10/2026

Pages 5 to 26 -- Weather Resistant Barrier (WRB) Application

Pages 27 to 29 -- Liquid Barrier Application (LBA) Application

Pages 30 to 31 -- Door Installation and Hinge Adjustment Instructions

If this set of instructions does not match your installation method or the wall conditions of the job site, please check our website listed below for other options, or call Quaker Customer Service for additional information.



Quaker Window Products  
504 Highway 63 S  
Freeburg, MO 65035  
Phone: 800-347-0438  
Fax: 573-469-4151  
[www.quakerwindows.com](http://www.quakerwindows.com)

## Note:

The details below show Out-Swing Door, Sidelite, and Transom options.  
The details within these instructions are based on the Out-Swing Doors (no transom)  
with Sidelite, but also apply all other Door/Frame options.  
When different, these options will be shown and noted.

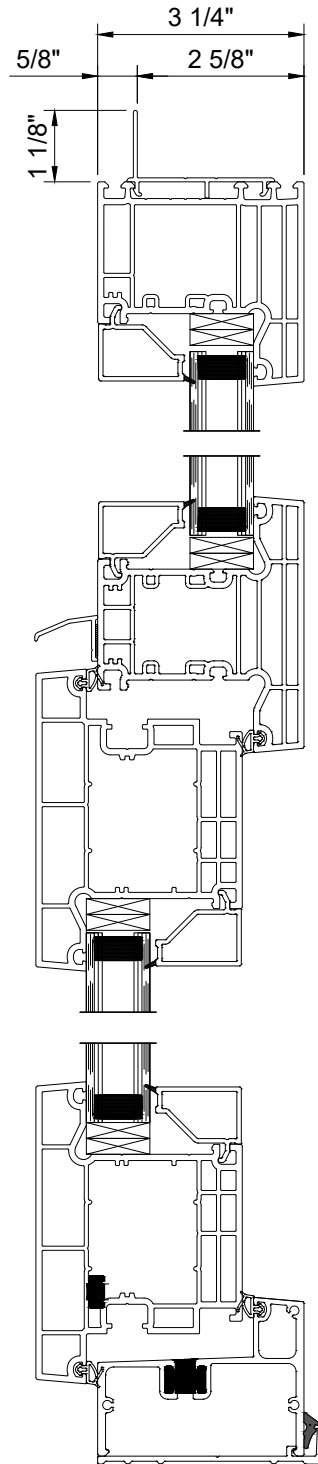

Out-Swing Door  
w/ Transom

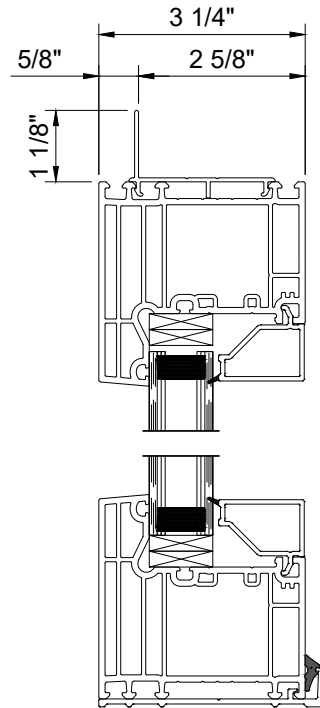

Sidelite

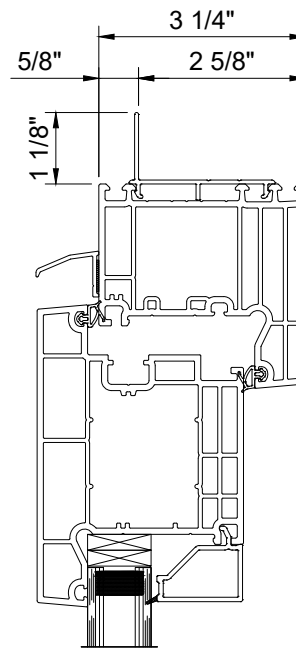

Out-Swing Door  
w/o Transom

## Tools Required by Installer

Safety Glasses



Drill/Driver



Level



Caulk Gun



Utility Knife



Metal Cutting Saw



Tape Measure



Staple Gun



Rubber Mallet



J-Roller



## Materials Required by Installer

Foam Backer Rod



Plastic Shims



Self-Adhering Flashing Tape



Perimeter Fasteners



Sealant



Denatured Rubbing Alcohol



## **-Carefully read these instructions before starting any installation-**

Failure to install and maintain QUAKER® products according to these instructions may void any product warranty. However, these are generic instructions that cover common situations and applications, aspects of which may not be appropriate for all installations due to building design, site conditions, construction materials, or installation methods used. Refer to shop drawings, if applicable, for additional notes and details. Please consult Quaker for specific applications not covered in these installation instructions, or visit our website at [www.quakerwindows.com](http://www.quakerwindows.com), or call 800-347-0438 for additional information.

### Tools

- Follow manufacturer's instructions and safely operate tools, ladders, or scaffolding. Always wear safety glasses. Failure to do so could result in injury, product, or property damage.

### Handling

- Do not store QUAKER products outside or in an unprotected, high moisture, or high heat environment prior to installation. Doing so could result in product damage.
- Do not carry, transport, or store QUAKER products in a flat (horizontal) position. Doing so could result in product damage or injury.
- Window and door units should be kept or stored in an upright (vertical) position, with support across the sill to avoid bowing. Do not lay any units in a flat position!

### Glass

- If glass gets broken, please exercise caution, as glass fragments can cause lacerations or other injuries. In many areas, local building codes require safety glass to be used in certain applications. All QUAKER products are available with safety glass if they are ordered that way.

### Fastening

- Metal fasteners and components could corrode when used in contact with preservative-treated lumber. Use approved and appropriate fasteners and components to fasten QUAKER products in this application. Failure to do so could result in a product performance failure, injury, or property damage.
- Quaker does not provide anchorage or fastener calculations.
- Quaker is not responsible for determining structural adequacy of the anchorage and fasteners used to install QUAKER products, or the openings into which they are installed.

### Installation

- Report any damage to dealer immediately. Do not install product if damaged. Quaker is not responsible for addressing products that are damaged after delivery, or product that is installed in a damaged condition.
- Always support window or door products in an opening until fully fastened. Failure to do so could result in the product falling out of an opening and causing injury, product, or property damage.
- Nailing flanges and drip caps (integral or applied) do not take the place of window flashing. All QUAKER products must be properly flashed and sealed with material compatible sealant for protection against water and air infiltration around the entire exterior perimeter. Failure to do so could result in a product installation failure and property damage.
- Windows and doors must be properly shimmed. To properly shim a QUAKER product, follow relevant installation guidelines, and never set a window directly on a sill plate. Failure to shim properly is an installation failure that could result in product performance failure or property damage.
- Construction directly above an opening must be engineered and designed not to transfer loads directly to any windows or doors. If live or dead loads are transferred to a QUAKER product, this may affect functionality and result in glass failure or otherwise damage frame joinery, perimeter seals, or other aspects of the product. Proper construction of the rough opening must take place prior to the installation of the QUAKER product.
- Please confirm that any necessary vertical deflection of the head condition is consistent with the selected QUAKER product. Most QUAKER products are not designed to allow any deflection at the head condition. Shop drawings may indicate the maximum allowable vertical deflection at the head condition of a QUAKER product. If vertical deflection is a concern but shop drawings are not provided, please contact Quaker for assistance.
- Windows and doors have small parts that, if swallowed, could pose a choking hazard to young children. Please dispose of unused, loose, or easily removed small parts. Failure to do so could result in injury or death.
- Do not drill through or into the sill or frame of any QUAKER products, whether to install alarm wires or for any other reason.
- During installation and positioning of any window or door products with an aluminum frame, make sure to align the thermal break of the product, with the insulation plane or air barrier of the building itself, in order to maintain continuity and integrity of the thermal envelope, and prevent thermal bridging that leads to excessive thermal transfer and/or condensation. In other words, the thermal break of the product must be recessed from the exterior plane of the wall opening, remain fully embedded within the wall opening, and not be exposed directly to exterior elements.

## Sealing

- Follow supplier instructions for proper application of minimally expanding foam, sealant, water resistant barrier or liquid barrier, and flashing products and systems to ensure safety, proper material application, compatibility, and to understand the need for periodic maintenance for continued weather resistance of their products. Failure to do so could result in product performance failure or property damage.
- Minimally expanding foam insulation must be compliant with AAMA 812.
- If silicone is selected as an appropriate sealant, Quaker recommends using 100% neutral cure silicone sealant, that is ASTM C920 compliant. Always clean and prepare the surfaces where the sealant will be applied per the manufacturer's recommendation. Once applied, properly tool the sealant in place. Failure to do so could result in product performance failure or property damage.
- Flashing tape must meet ASTM-D779 performance requirements.
- Maintain and properly seal a minimum of 1/4" gap (or whatever is specified within these installation instructions or shop drawings) around the perimeter of the window or door frame and the exterior finish materials. Failure to do so could result in product installation failure or property damage.

## Joining

- Do not join any Quaker product to another product that is not designed for joining. Joined products must be individually supported in the opening. Failure to do so could affect operation and product performance and could result in a product installation failure or property damage.

## Cleaning

- Do not use any cleaning agent other than a mild, non-abrasive window washing solution or glass cleaner applied in accordance with any product labeling instructions and Quaker's care and maintenance instructions. The use of harsh chemicals (such as brickwash, bleach, alcohol, hydrochloric acid, or muriatic acid) for cleaning or other purposes may damage QUAKER products, glass, fasteners, hardware, seals, sealant, or metal flashing. Please protect these products by following the cleaning product's instructions for its proper use.
- Do not use a razor blade to clean a glass surface, as damage to the glass may result.

## IMPORTANT

- Buildings constructed prior to 1978 may contain lead paint which could be disturbed during window or door replacement. For more information on proper management of lead paint, go to: [www.epa.gov/lead](http://www.epa.gov/lead)
- Care must be taken to properly recycle or dispose of used or old materials. Any recyclable material should be separated from non-recyclable or hazardous materials. Please consult with local or state authorities regarding proper disposal of non-recyclable or hazardous materials.
- Inspect all window and door units for any damage or defects prior to installation. Contact the nearest QUAKER distributor if there are any problems or issues.
- **WARNING:** This product can expose you to chemicals, including titanium dioxide or methanol, which are known to the State of California to cause cancer and birth defects or other reproductive harm. For more information go to [www.P65Warnings.ca.gov](http://www.P65Warnings.ca.gov)
- **WARNING:** Drilling, sawing, sanding, or machining wood products can expose you to wood dust, a substance known to the State of California to cause cancer. Avoid inhaling wood dust or use a dust mask or other safeguards for your personal protection. For more information go to [www.P65Warnings.ca.gov](http://www.P65Warnings.ca.gov)
- When installation is completed, operable window and door products, and related hardware or equipment, may require some adjustments. Confirming operability and making minor adjustments are within the scope of the installation services performed by others.
- **WARNING - OVERHANG NEEDED:** It is recommended that doors (swing and sliding) with ADA or Low-Profile Sills be installed with an overhang depth equal in length to the height of the door. If you choose to use an overhang depth less than the height of the door, you must confirm that it is appropriate based on code requirements and the expected local wind and rain conditions.

These instructions are based on an Out-Swing Door on the right side with a Sidelite to the left without transoms (viewed from exterior). Other configurations will be installed in a similar manner (see shop drawings if applicable).

The remainder of the installation up to WB5 on page 26 will show Weather Resistant Barrier surrounds.

When using Liquid Barrier, the installation will be the same.

Go to instruction LB1 on page 27 for Liquid Barrier installation and sealing instructions.

## BR1

If not already done, insert backer rod into the interior and exterior slots as shown below.

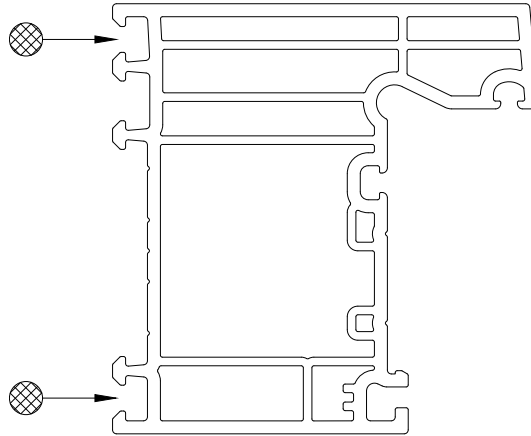

## RO1

From the interior, measure and verify the size of the rough opening. The rough opening should be a minimum 3/4" wider and 1/2" taller than the Total Unit size, unless otherwise specified on the shop drawings. Verify the rough opening is flat, plumb, level, and square. Take diagonal measurements to check for square.

The sill structure beneath the unit must be level for proper unit operation.

Go to the exterior and cut the Weather-Resistant Barrier (WRB) in an 'I' pattern.

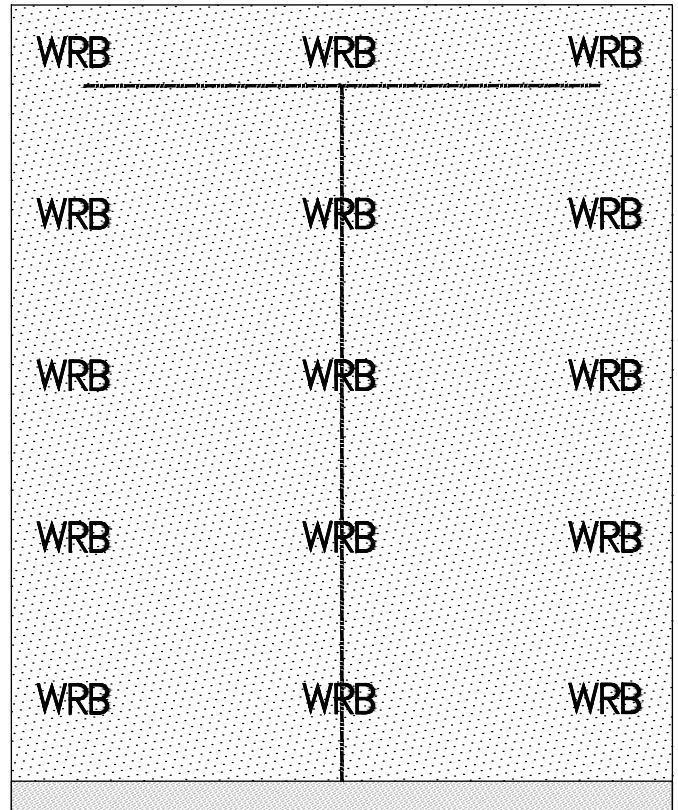
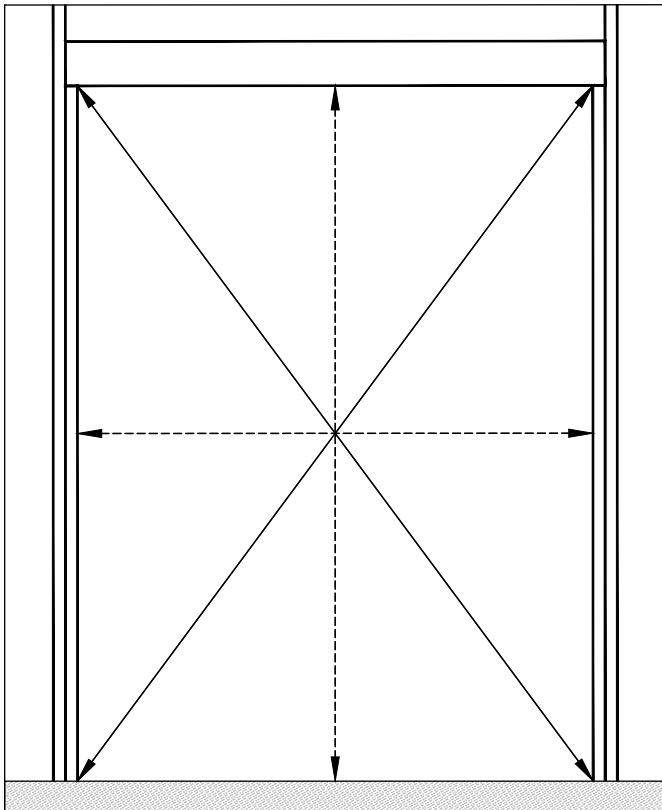

## RO2

Fold the WRB sides towards the interior and trim as needed. Do not staple in place. Make 4"-6" horizontal cuts in the WRB at the head and sill jambs. Make a 45° x 6" long cut at the head condition. Fold back WRB at the cut lines, and tape into place.

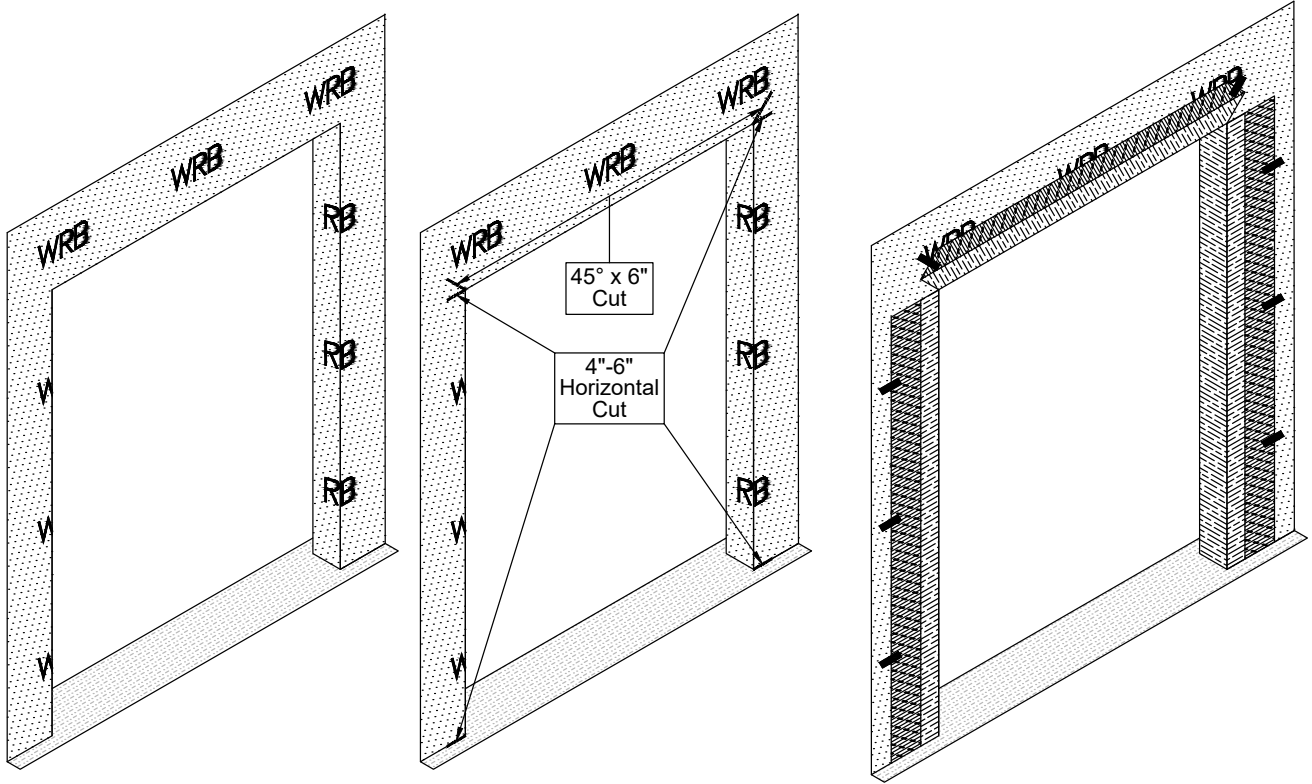

## RO3

Apply sealant at the jambs where shown. Fold the WRB jamb flaps back into place, over the sill flashing, and fix into place. Leave head flap in place.

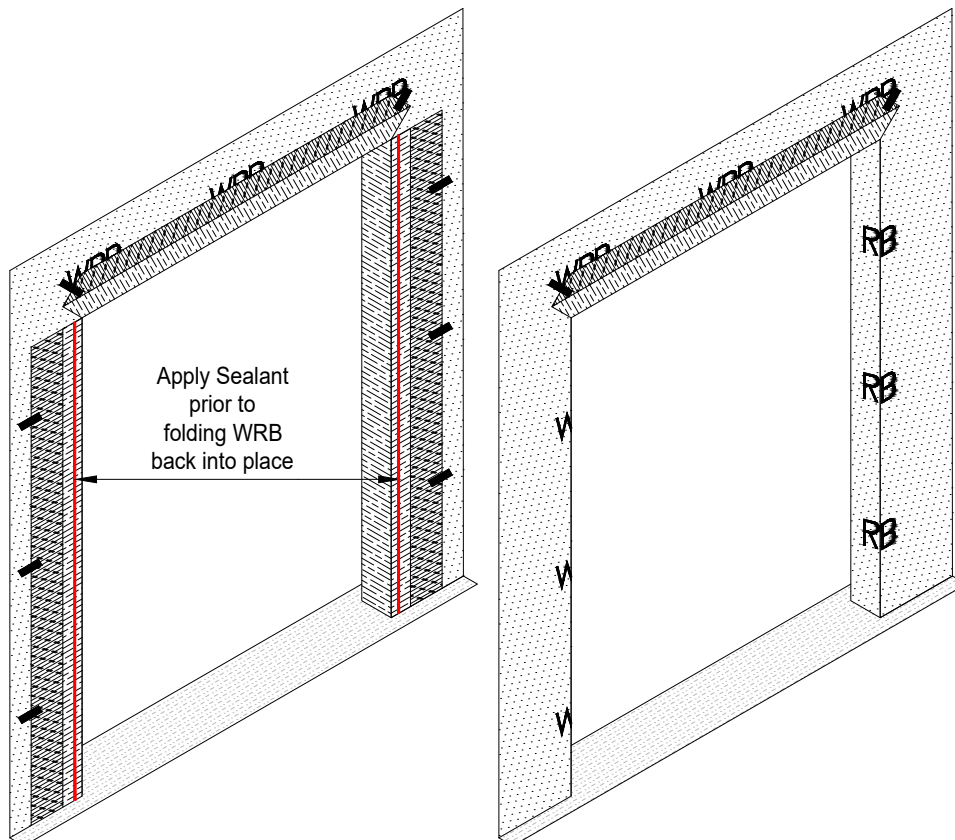

## NOTE:

For easier installation, remove the door from the frame. Open the door 90° and lift it off the hinges. Place the door in a safe area where it can not be damaged. See page 30 and 31 for hinge adjustment instructions.

**FF1**

Seal the inside and outside snap areas where shown, then snap the Flashing Flange into place with the flange to the exterior. If a Mallet is needed to engage Flashing Flange use a wood block in between the fin and the mallet.

-DO NOT HIT THE FLASHING FLANGE DIRECTLY WITH THE MALLET-

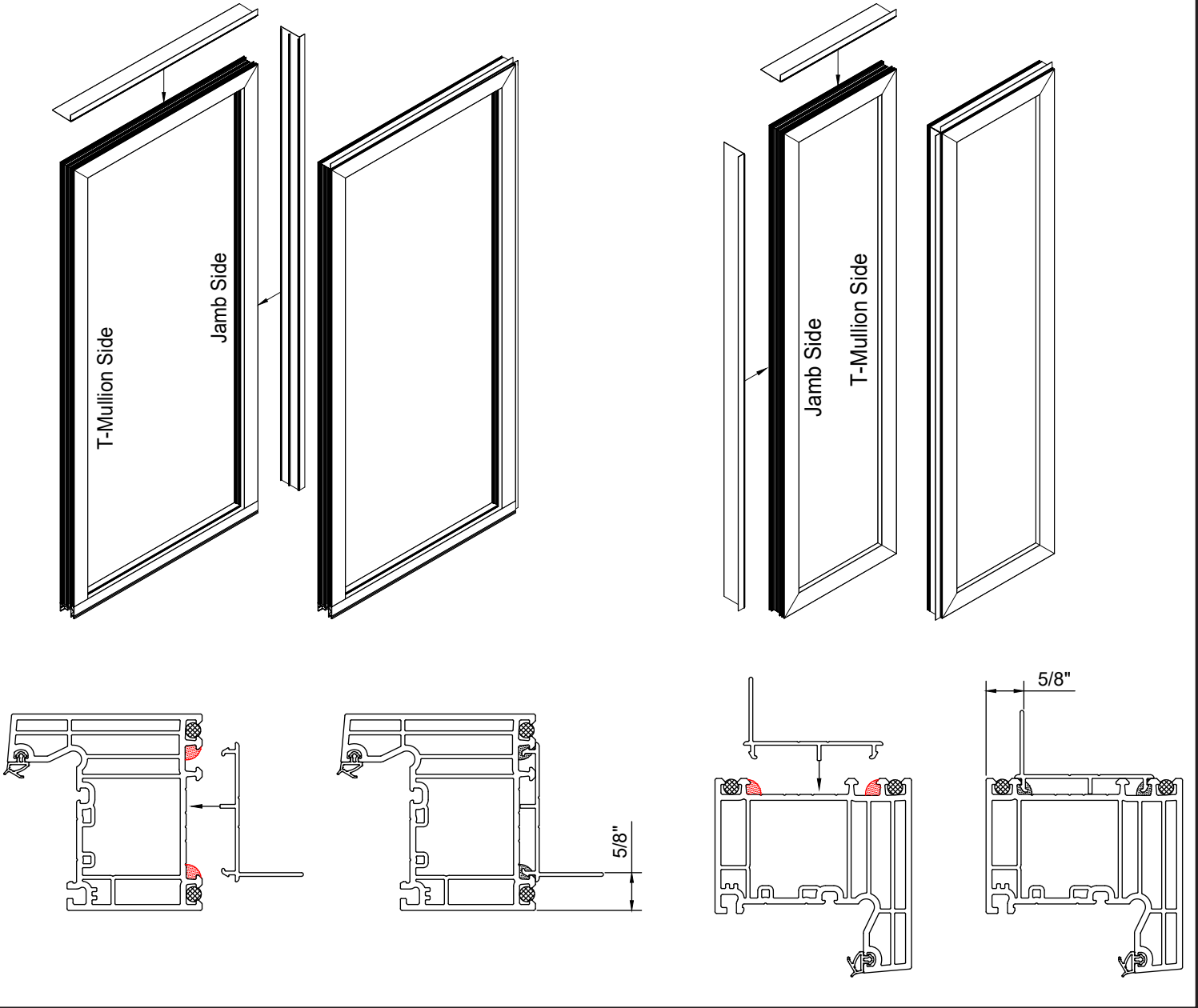

# Sill Pan Installation

## SP1

Cut the Sill Pan to fit allowing a 1/8" gap between the rough opening and the ends of the Sill Pan. Measure and set a chalk line on the subfloor 2 15/16" in from the exterior wall face. Dry fit the Sill Pan system with the rear upturned leg on this line. Check to see if the Sill Pan is level, and if not, be prepared to level area. Quaker first recommends **self-leveling concrete**. If not available, use plastic shims as needed to ensure system is level.

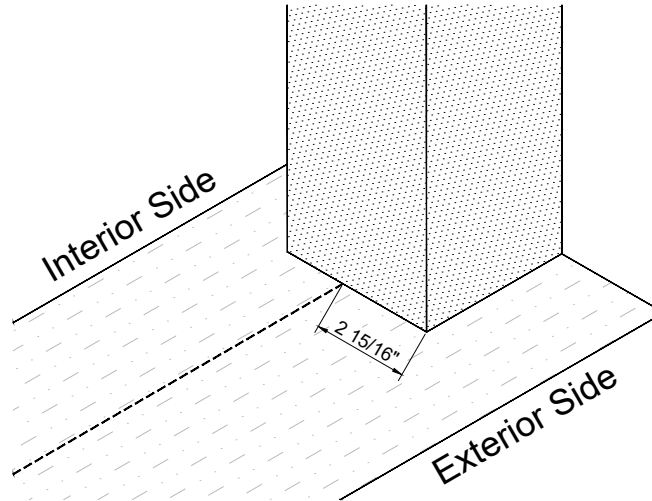

Snap another chalk line the width of the Sill Pan, from the previous chalk line. This is where the Sill Pan will sit.

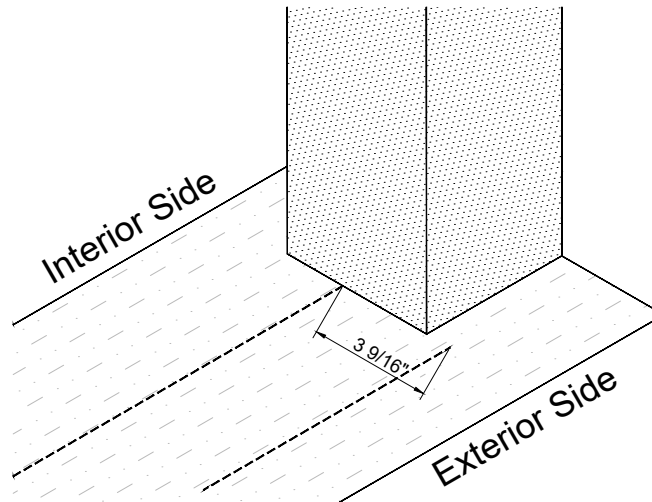

Dry fit the Sill Pan to ensure proper alignment and to verify if level. **DO NOT** seal or fasten Sill Pan in place yet.

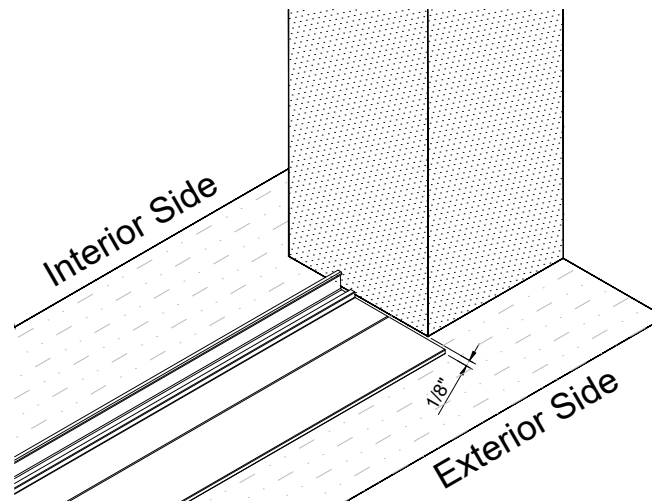

# SP2

Apply (3) 3/8" continuous beads of sealant across the entire width of the rough opening sill where the Sill Pan will set. Apply a 3/8" bed of sealant the depth of the Sill Pan being used, 1/2" from each side of the opening at the jambs.

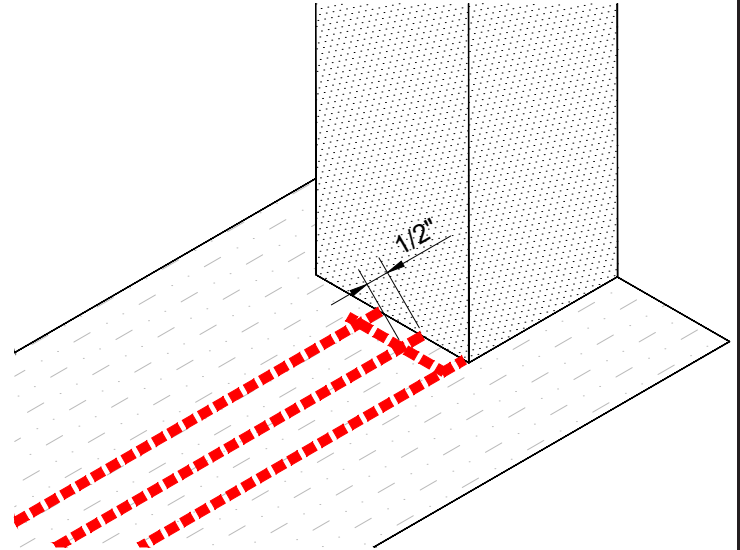
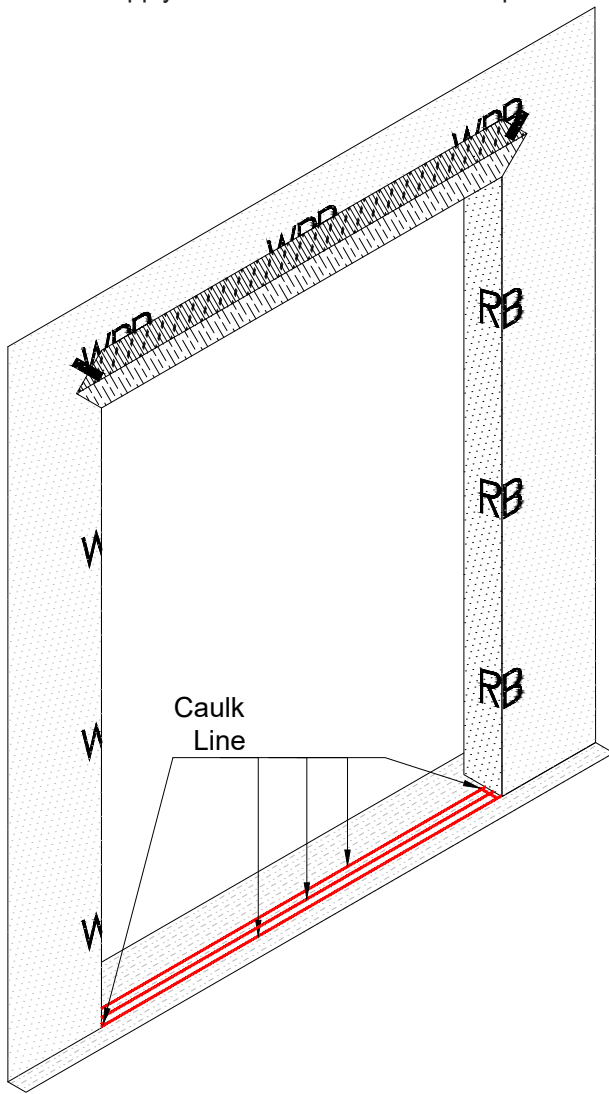

# SP3

Allow an 1/8" gap between the rough opening and the Sill Pan at both jambs.

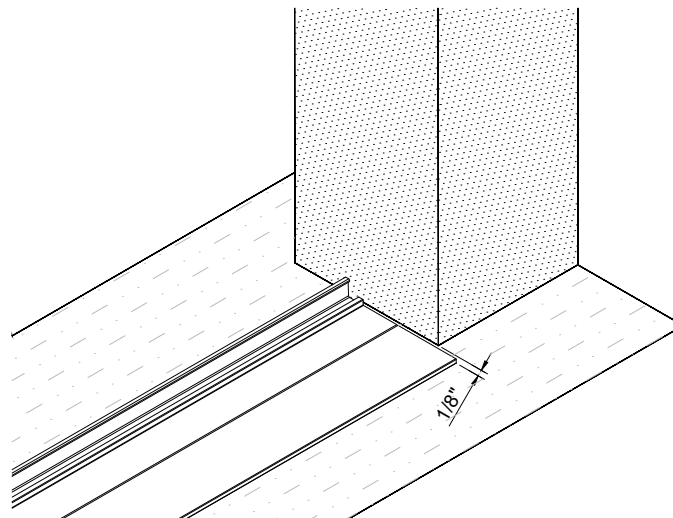

# SP4

Drill somewhere within the 1 5/8" dimension shown (make sure to leave enough room for screw heads). If pan head fasteners are being used, the head height cannot exceed 3/16". Drill bit size is determined by required screw size. Drill 3" from ends, and then at 14" O.C.

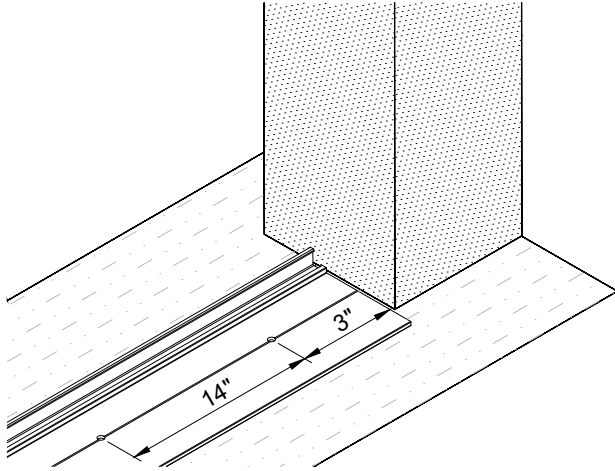

If the Sill Pan is not continually supported, add a continuous support as shown

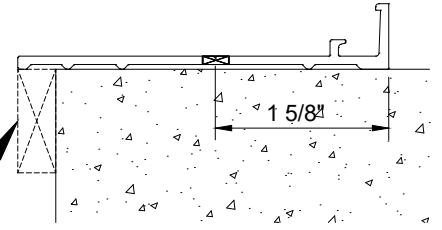

# SP5

Match drill the holes into the sill building construction. Fill these holes with silicone sealant and fasten the Sill Pan in place. After installing the perimeter fasteners, apply silicone over the screw heads and tool.

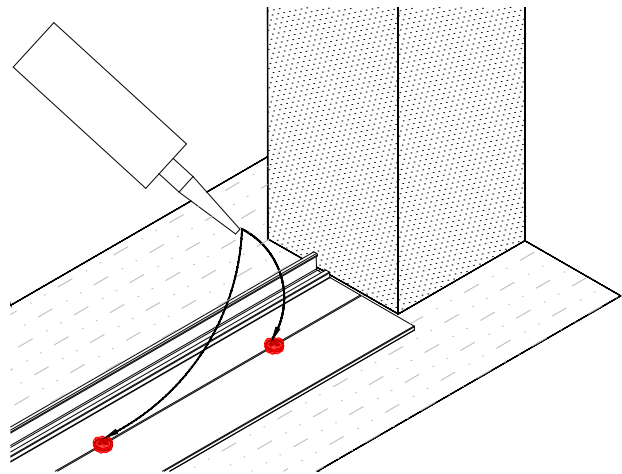
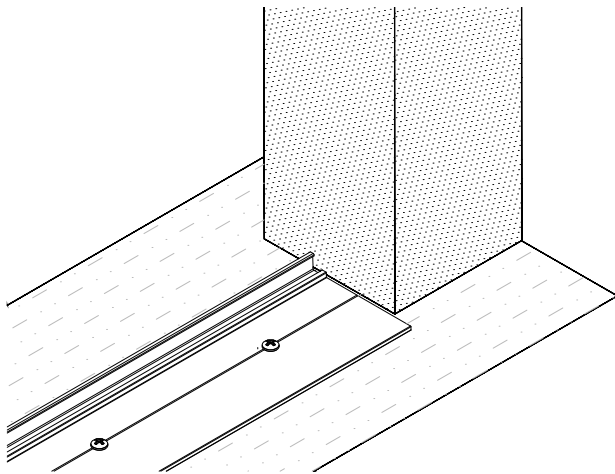

# SP6

With the Sill Pan in place, apply silicone sealant along the Sill Pan and along the upturn leg.

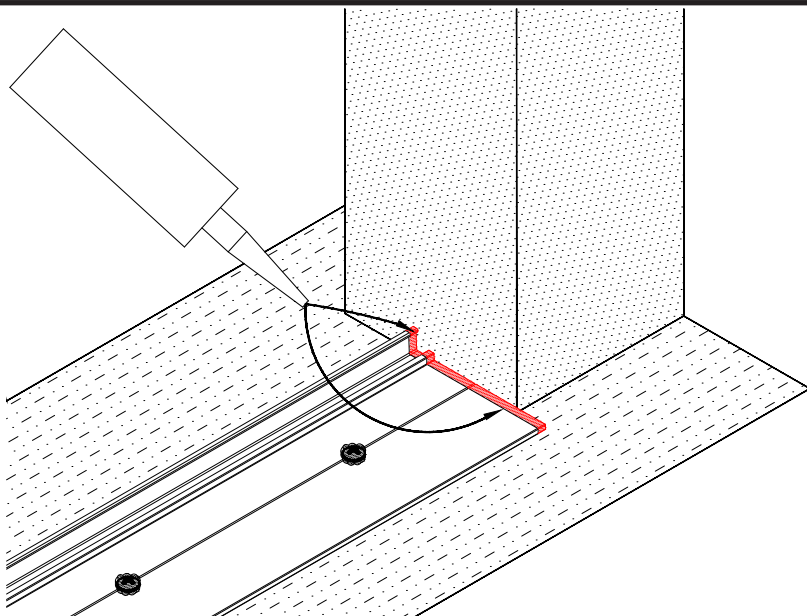

# Door and Sidelite Frame Installation

**FI1**

At the Door Frame, the perimeter fastener locations will need to be located per the Shop Drawings or the anchorage calculations. First, drill a 3/8" diameter clear hole where required at the Door Side, then drill the appropriate sized clear hole.

At the Sidelite Frame, remove all of the interior glass stops. The perimeter fastener locations will need to be drilled and countersunk per the Shop Drawings or the anchorage calculations. Take care to not damage the glass/infill.

NOTE: Drill Flange from 'exterior' side as noted below.

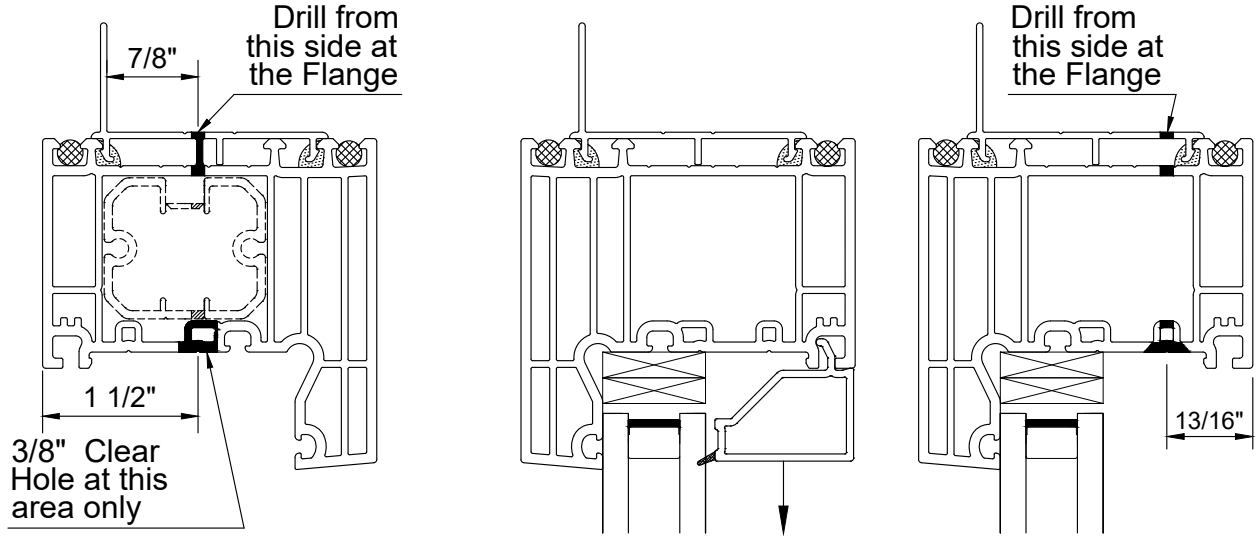

**FI2**

Apply a generous amount of sealant around the interior side of the Door Frame Flashing Flange as shown in the sketch below.

**-WRB and Liquid Barrier Supplier is required to specify what type of sealant should be used for compatibility-**

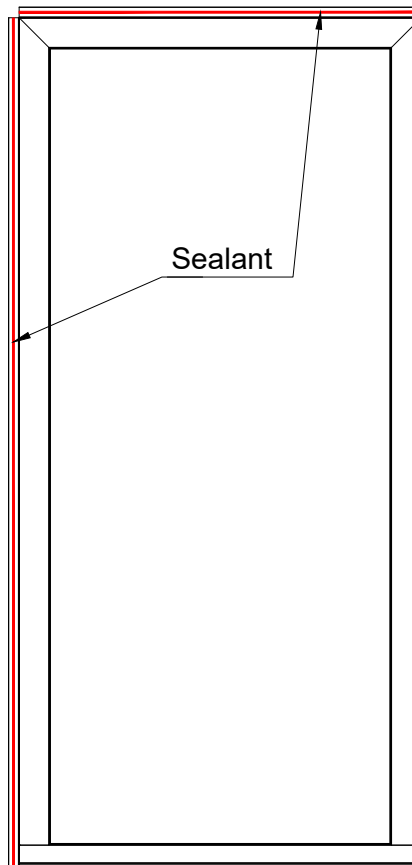

# FI3

Before inserting the Door Frame assembly into the opening, run a bead of silicone sealant into the groove at the Sill Pan. The sealant should run jamb-to-center of 'T' Mullion, and marry to the Sill Pan jamb sealant. Install the frame assembly by tilting top out and sliding it into the rough opening from the exterior side. Set the frame assembly onto the Sill Pan as shown below.

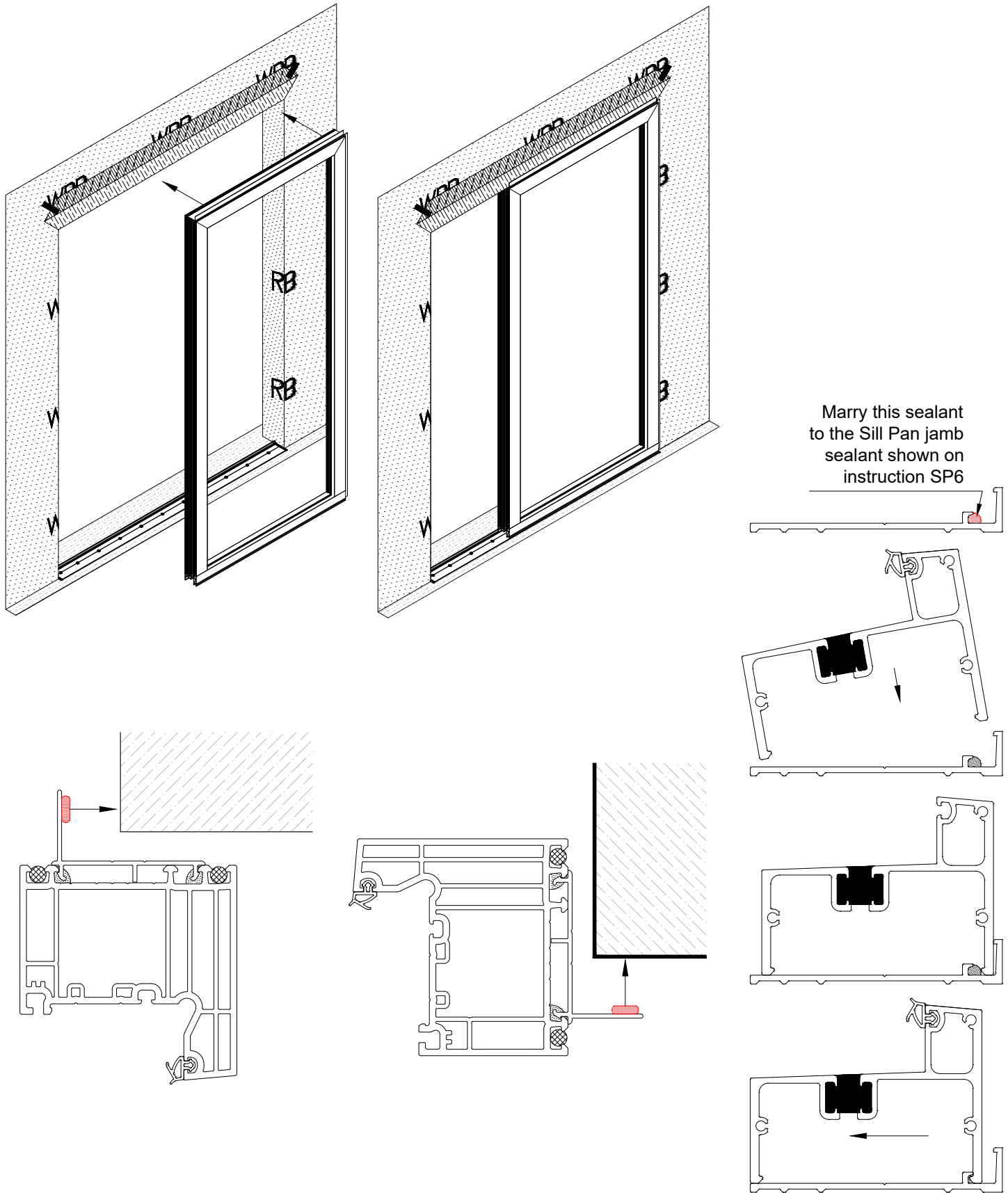

**FI4**

Verify head frame is level, plumb, and square.  
Temporarily secure the frame assembly in the opening at the head corners.

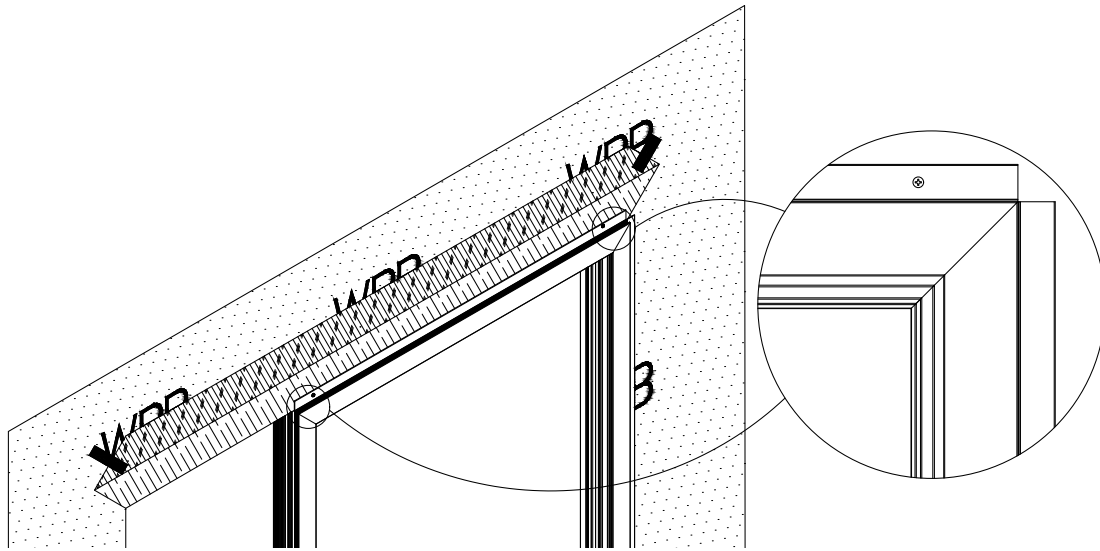

**FI5**

Install plastic shims as needed where the fasteners in the Door Frame are located.  
Attach the Door Frame to the surrounding conditions. Do not over-tighten the fasteners.  
When all fasteners are in place, install the provided Hole Plugs.

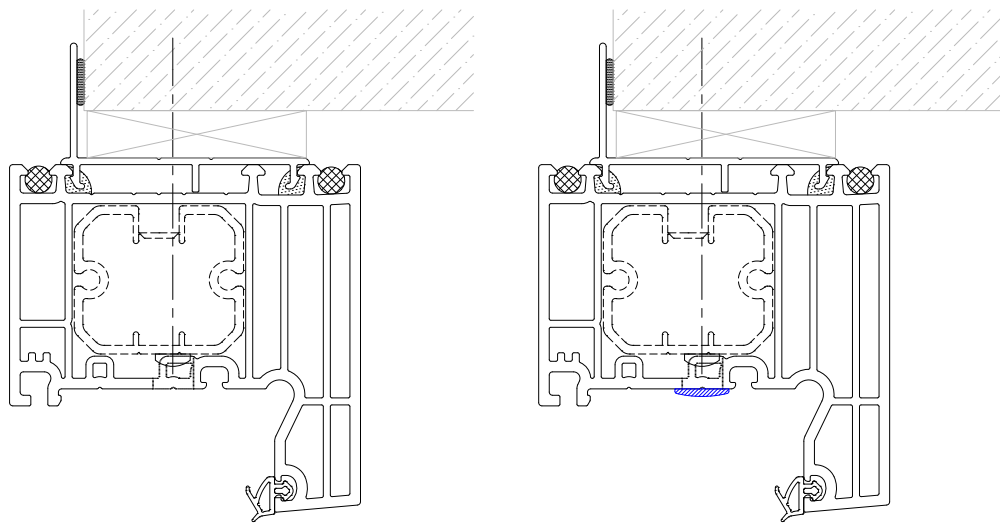

# FI6

If not already done, cut the 'T' Mullion, interior Cover, and Pressure Plate to size. The 'T' Mullion will be equal to the door frame height. The Pressure Plate and interior Cover will be  $11/16$ " less than the 'T' Mullion. A notch at the bottom of the 'T' Mullion is required as shown below. Position the Angle Clips where shown below and match drill the 'T' Mullion with a #27 Drill Bit (0.141 Dia.). Attach the Angle Clips with the supplied #8 Fasteners.

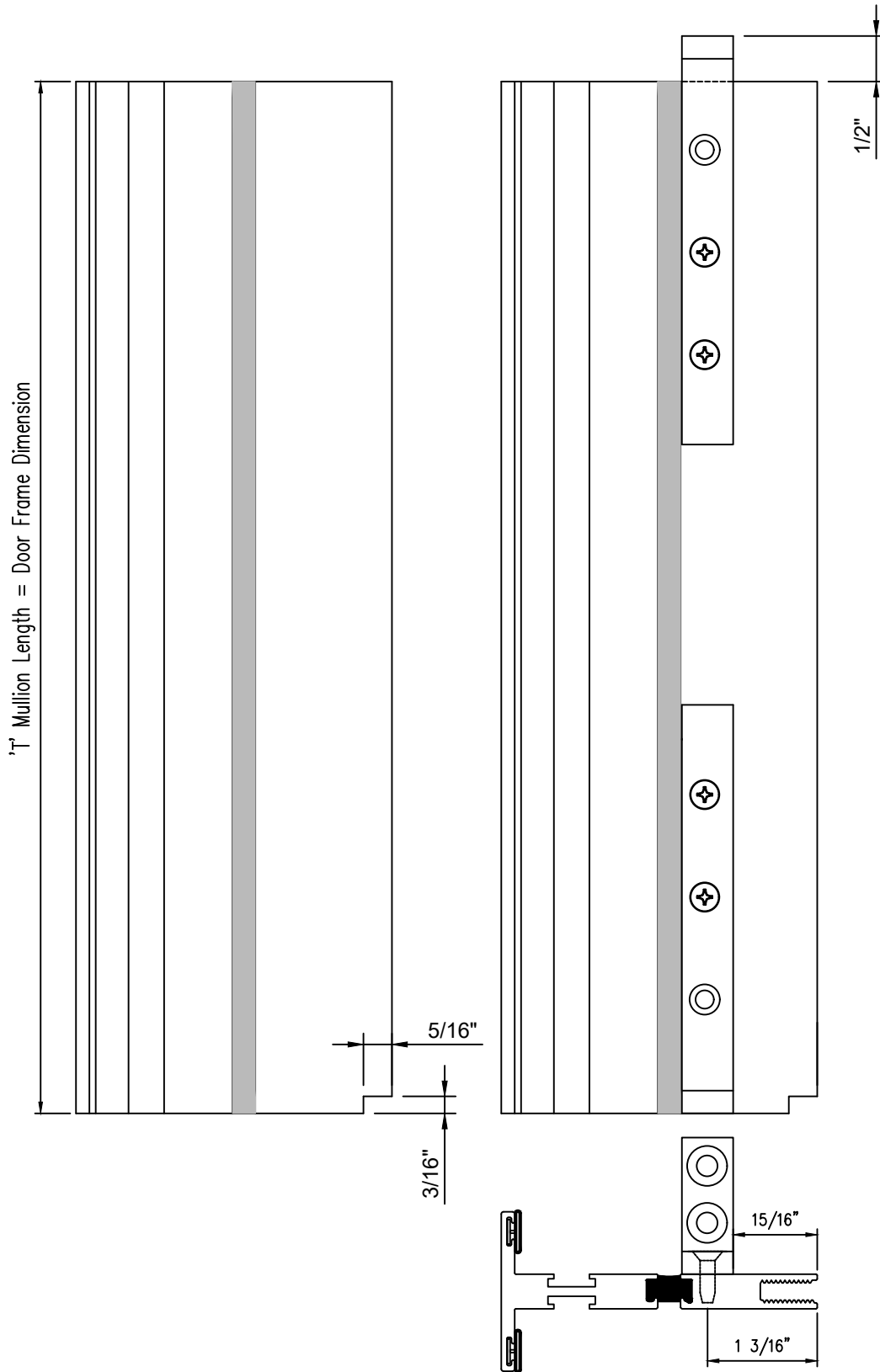

# FI7

Apply a generous amount of sealant to the Sill Pan where the Angle Clip will sit (see dimensions below), and on the exterior leg of the 'T' Mullion as shown below. Then install the 'T' Mullion assembly against the door frame by sliding it into place from the exterior. Push firmly against the door frame as shown. Tool sealant as needed.

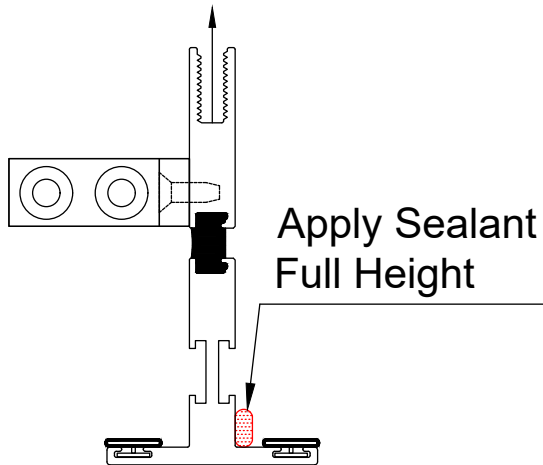
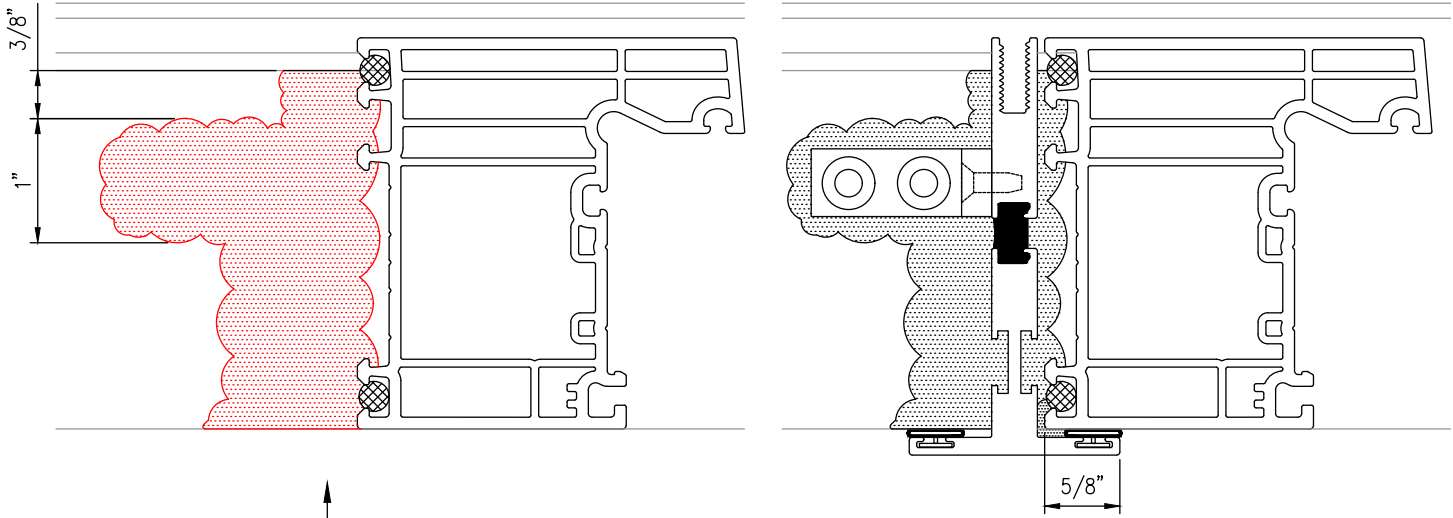

# FI8

When positioned correctly, fasten the Angle Clips in place. Securely seal the fastener heads at the sill Angle Clip and tool as needed. Sealing around the head Angle Clip and fasteners is optional.

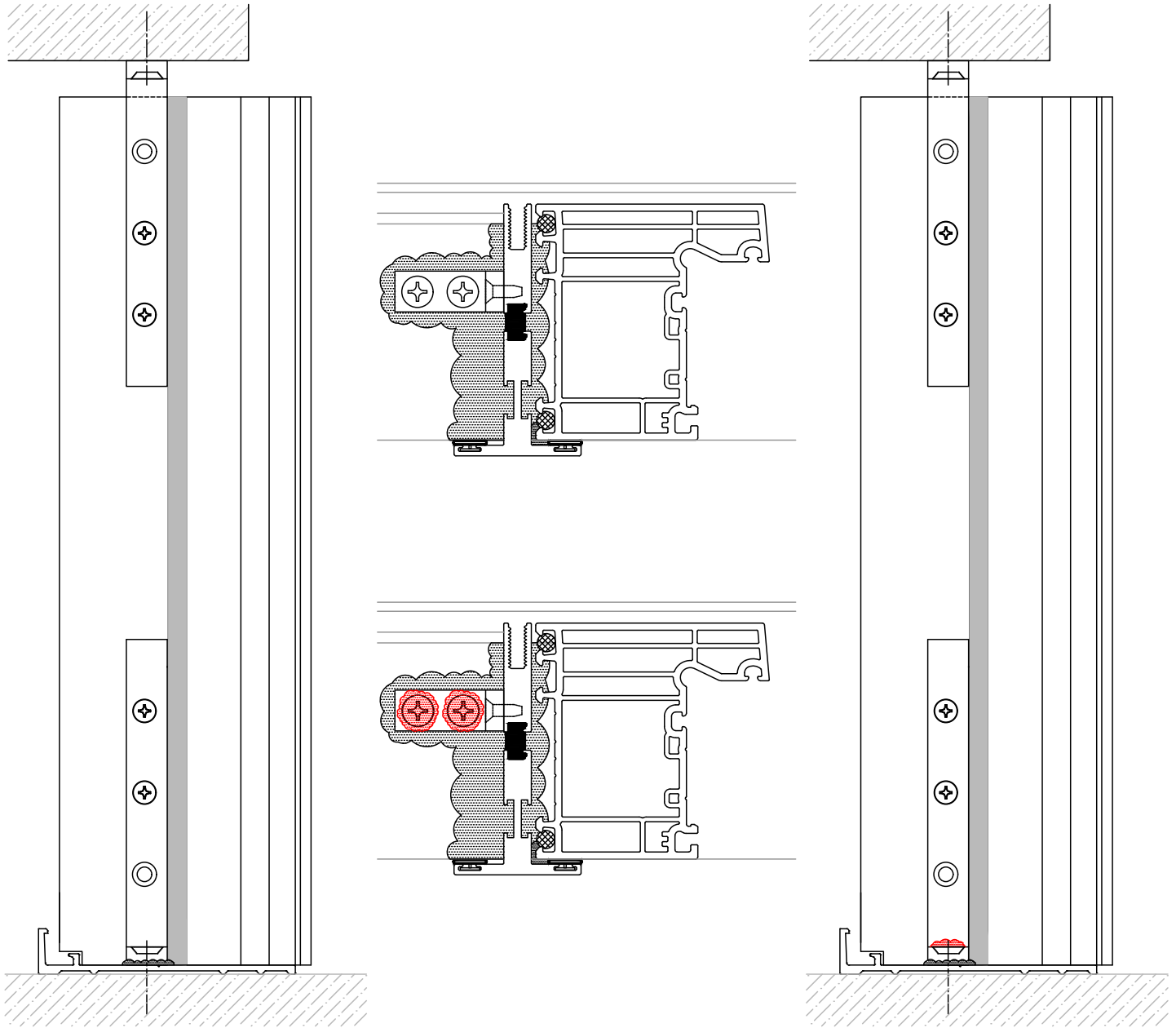

# FI9

Before inserting the Sidelite Frame assembly into the opening, run a bead of silicone sealant into the groove at the Sill Pan. The sealant should run jamb-to-center of 'T' Mullion, and marry to the Sill Pan jamb sealant and the Door Frame Sealant applied in instruction F12. Then apply a generous amount of sealant on the exterior leg of the 'T' Mullion as shown below.

Marry this sealant to the Sill Pan jamb sealant shown on instruction SP6

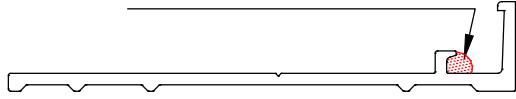

Apply Sealant Full Height

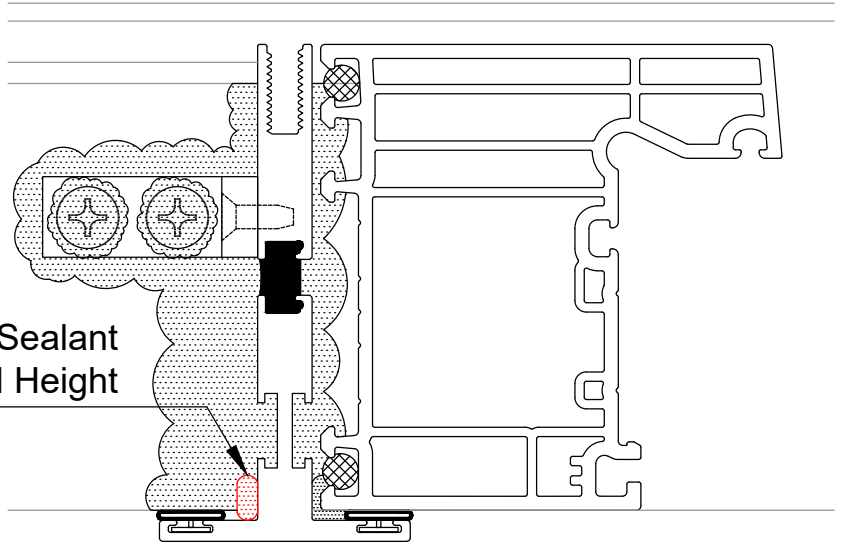

# FI10

Notch the inside corners of the Sidelite Panel as shown below. This is required so the panel can 'hook' into the Sill Pan. Then apply a generous amount of sealant around the interior side of the Door Frame Flashing Flange as shown in the sketch below.

**-WRB and Liquid Barrier Supplier is required to specify what type of sealant should be used for compatibility-**

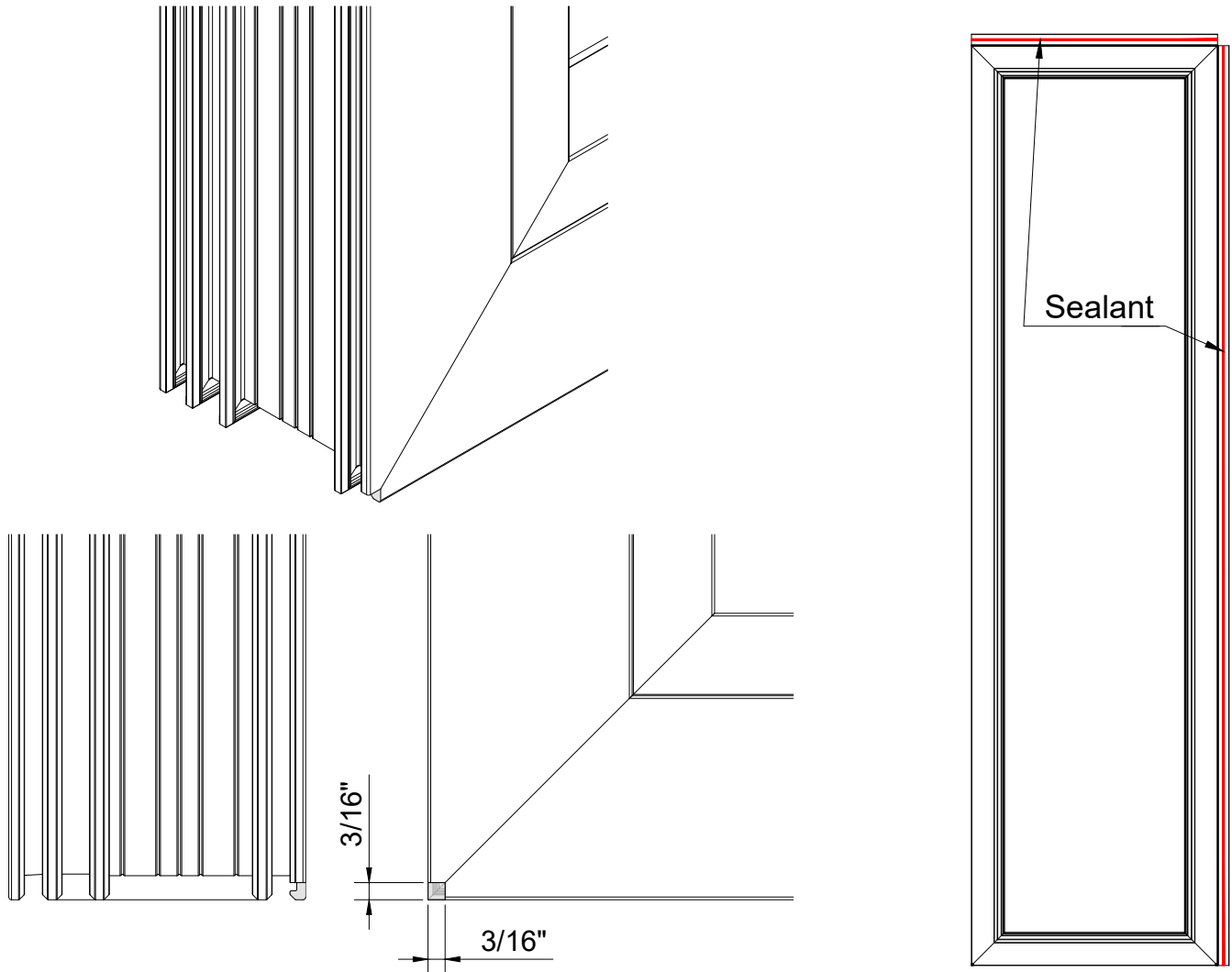

# FI11

Before inserting the Sidelite Frame assembly into the opening, run a bead of silicone sealant into the groove at the Sill Pan. The sealant should run jamb-to-center of 'T' Mullion, and marry to the Sill Pan jamb sealant. Install the frame assembly by angling it into the opening, and turning it into place. Make sure to lift the frame over the Sill Pan tab and the 'T' Mullion Clip. Set the frame assembly onto the Sill Pan as shown below.

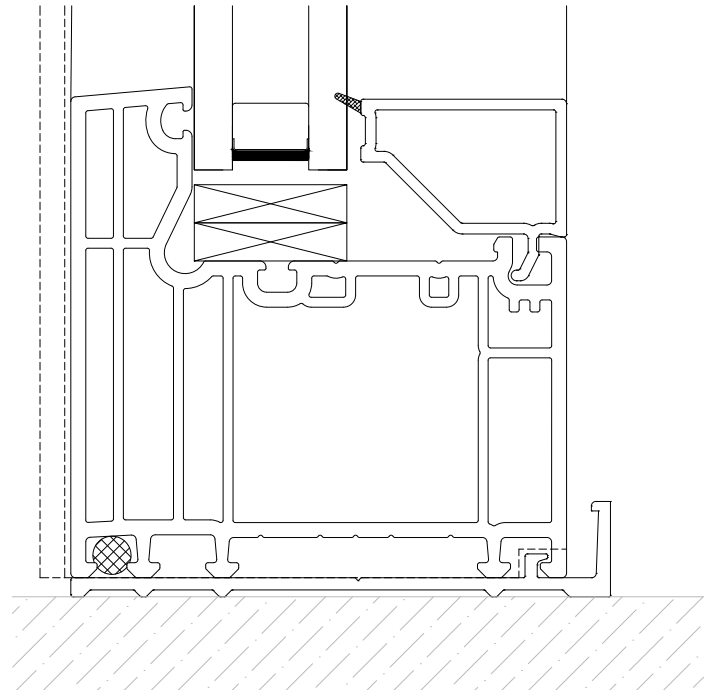
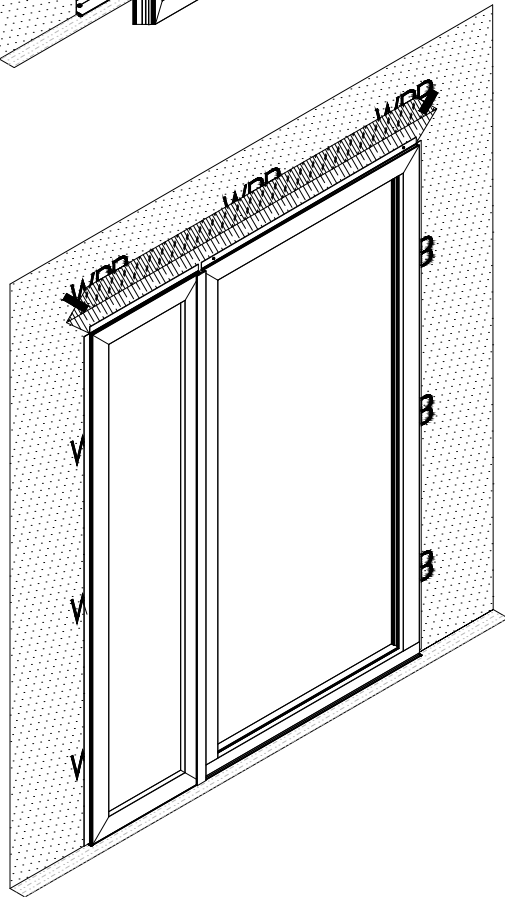
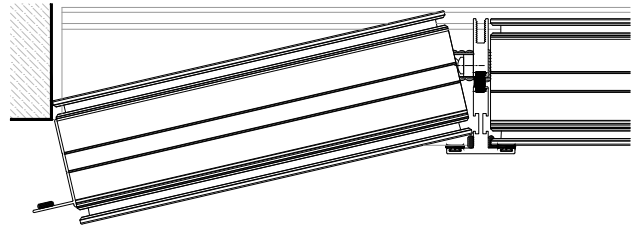
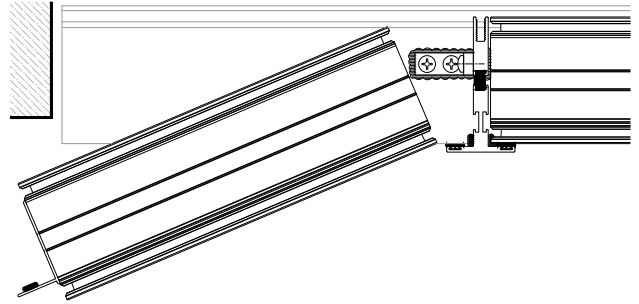
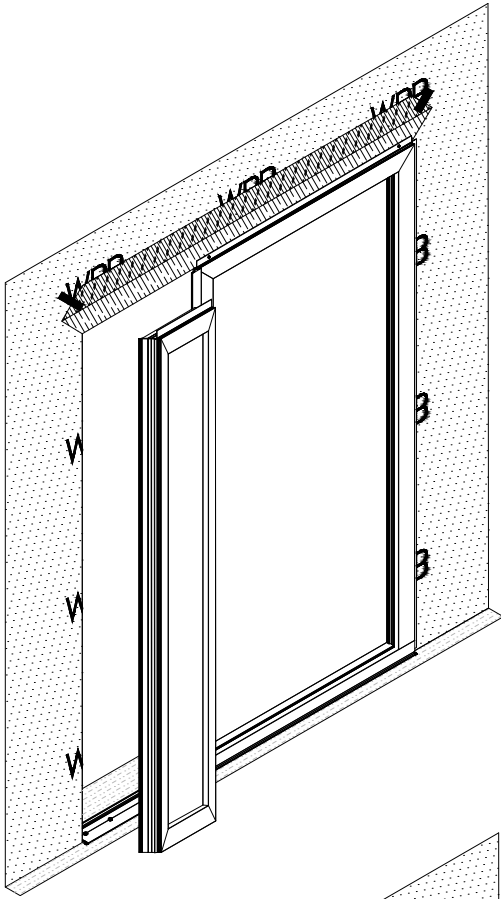

# FI12

Verify head frame is level, plumb, and square.  
Temporarily secure the frame assembly in the opening at the head corners.

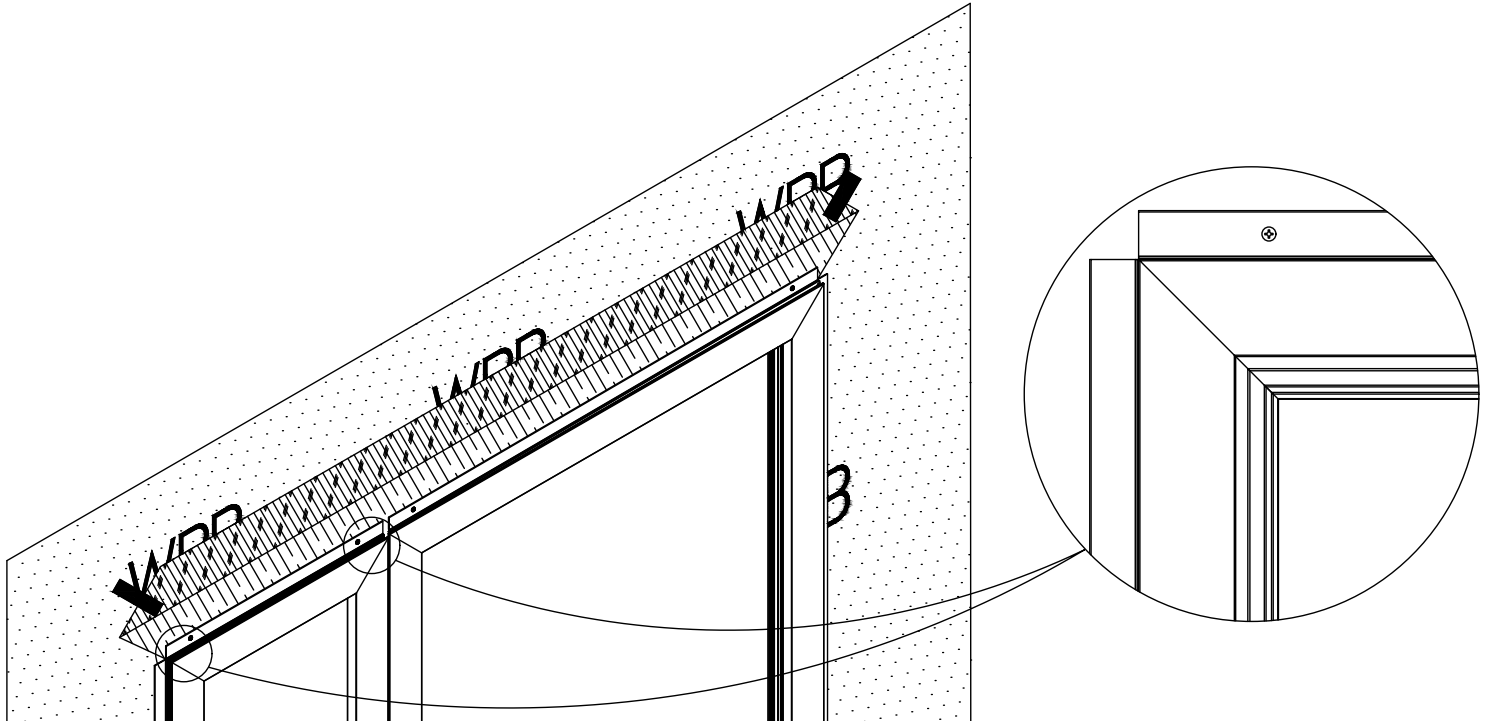

# FI13

Install plastic shims as needed where the fasteners in the Sidelite Frame are located.  
Attach the Sidelite Frame to the surrounding conditions. Do not over-tighten the fasteners.  
When all fasteners are in place, re-install the Glass Stops.

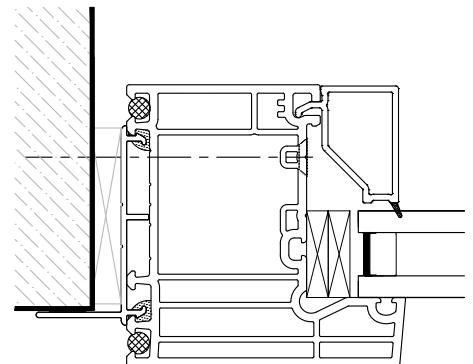
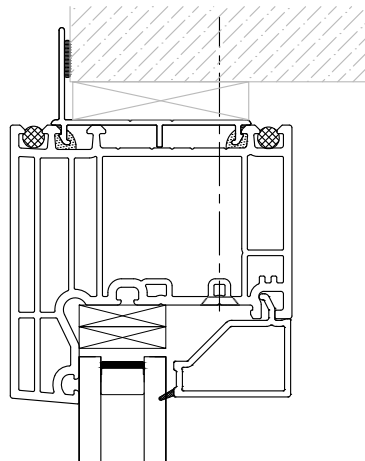
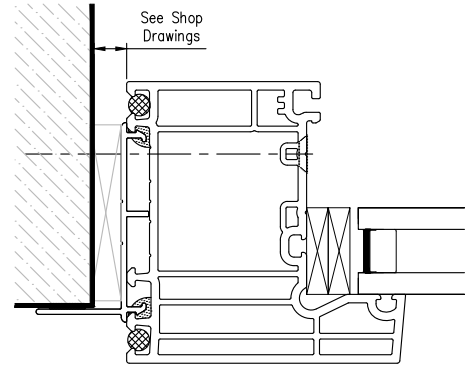
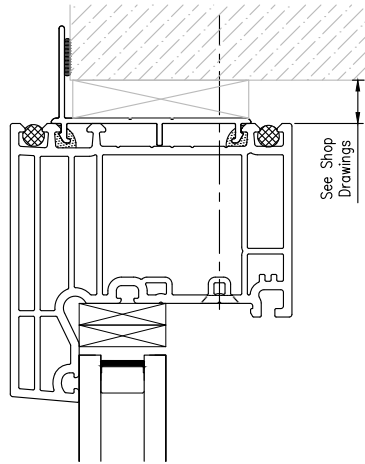

# FI14

Apply sealant full height at the window to T-Mullion area, and 6" from the top and bottom at the T-Mullion raceway as shown below.  
Apply the Pressure Plate with the supplied fasteners, 3" from the ends and 12" O.C.  
Make sure the fasteners are installed straight, and do not over-tighten the fasteners to ensure

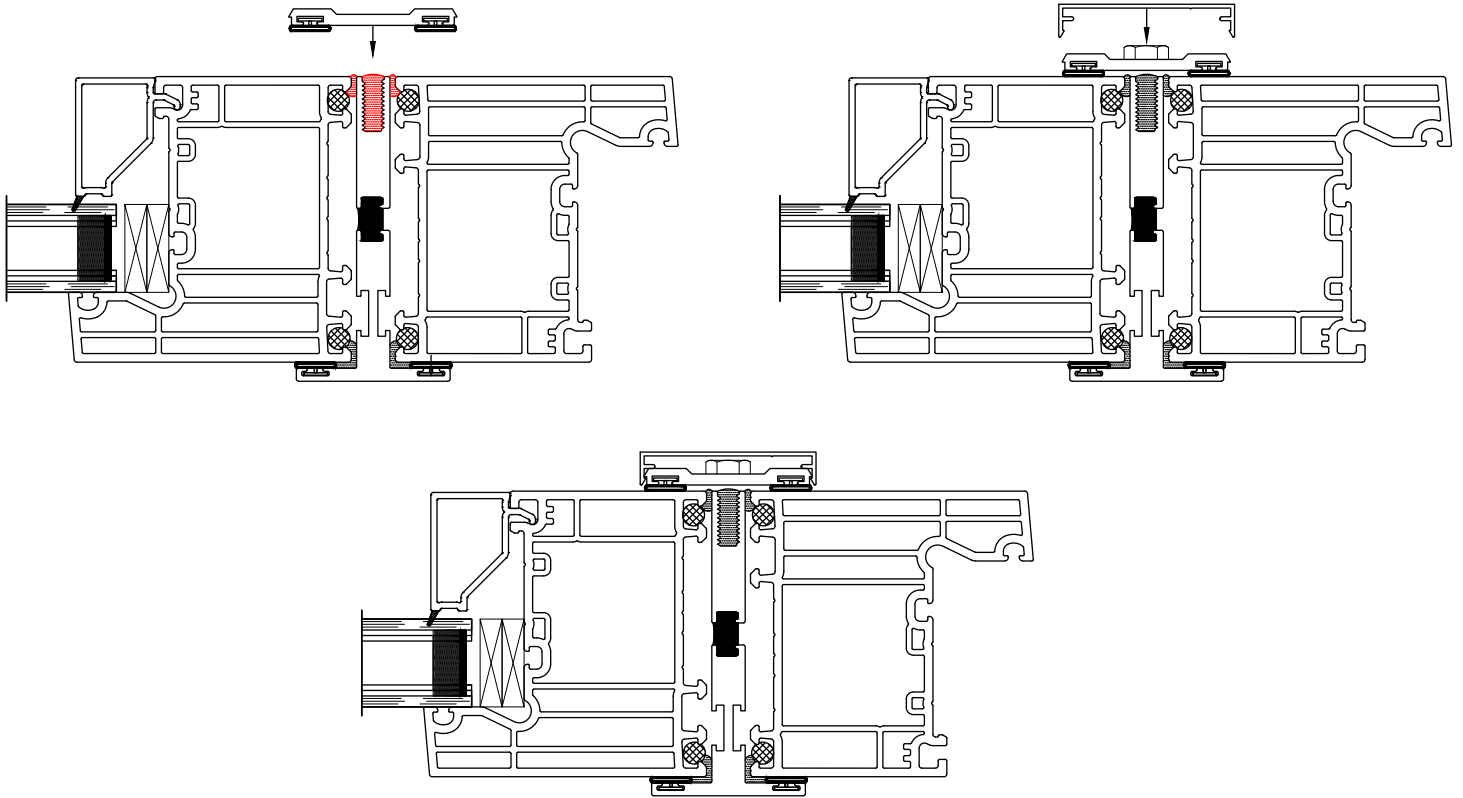

# FI15

Push the Wedge Gasket in to place.

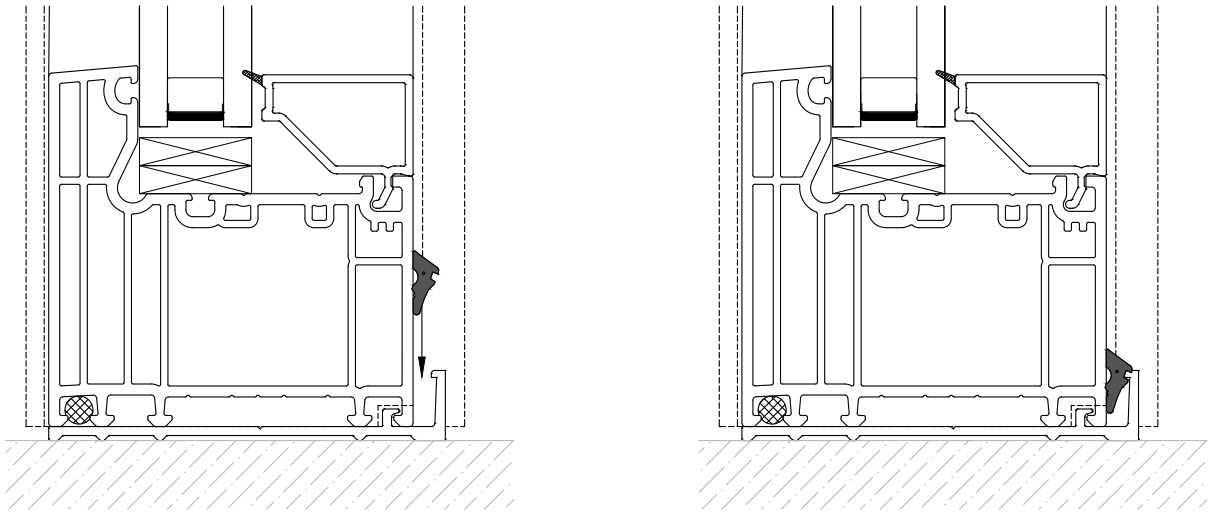

# FI16

After frame installation is complete, apply silicone sealant to the corner joints. Also where the frames meet the 'T' Mullion, fill the voids with backer rod and seal securely.

Install the (2) Top Foam Corner Gaskets over the exterior side of the Flashing Flange corner gaps.  
Tool the sealant as needed.

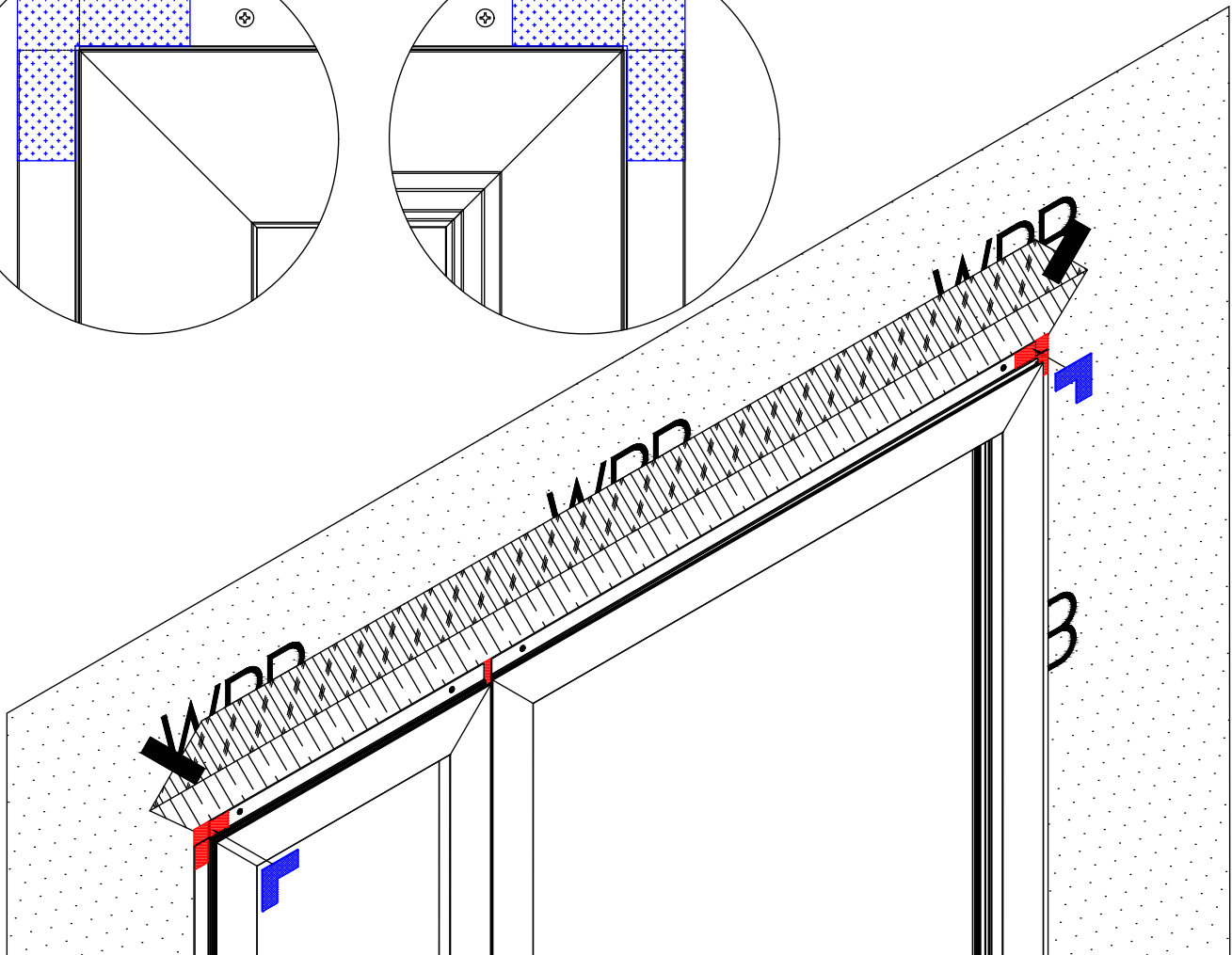
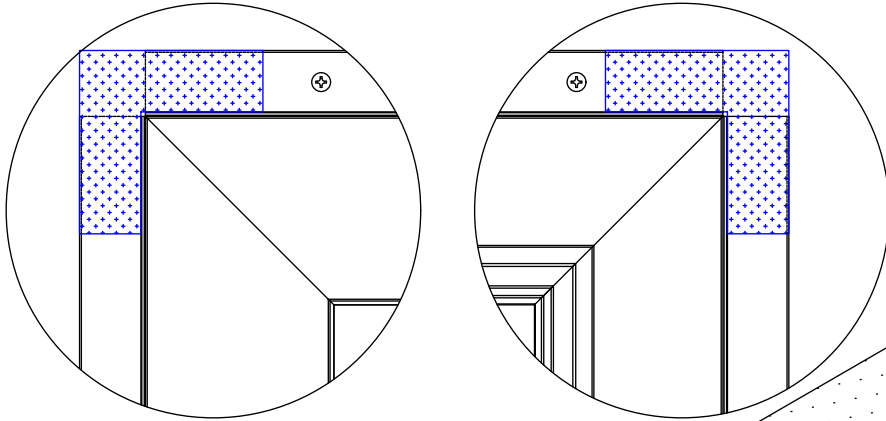
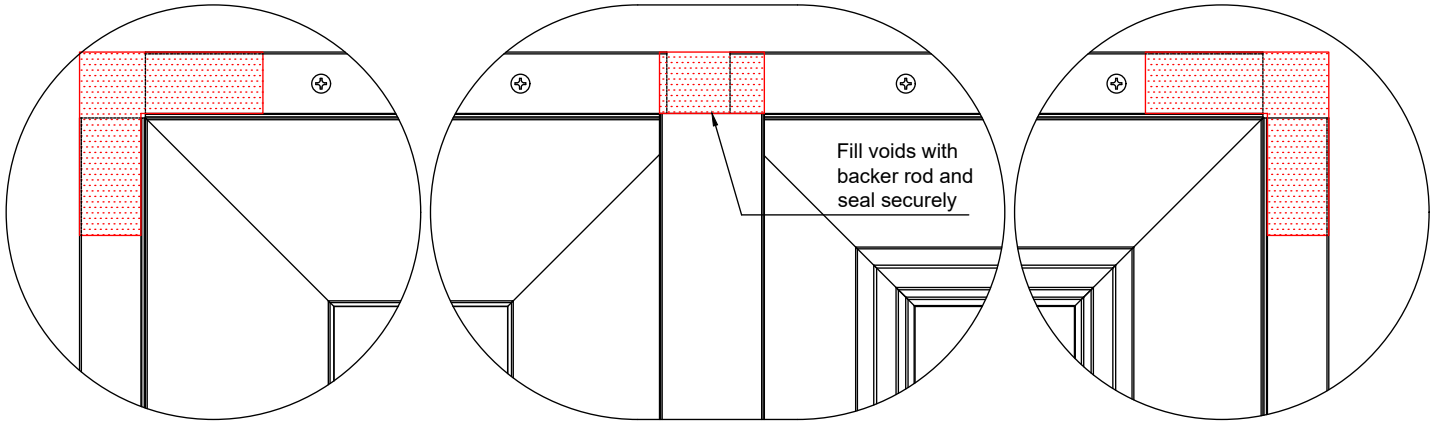

# FI17

## This step must be done for this application.

If not sized on the Shop Drawings, field size continuous Flashing that will cover the exterior of the Windows and 'T' Mullion. Ideally, this Flashing will extend past the facing of the building. Not extending the brake metal to the building face may cause water penetration to the interior, that Quaker Windows will not be responsible for. Apply sealant to the top of the head and T-Mullion. Set the Flashing into place and if required attach the flashing to building and apply sealant over the fastener heads. Tool the sealant as needed.

Then seal the top and sides of the Flashing to the building.

At the bottom of the T-Mullion where it extends past the sill flashing, seal securely around the T-Mullion face.

Tool all sealant as needed.

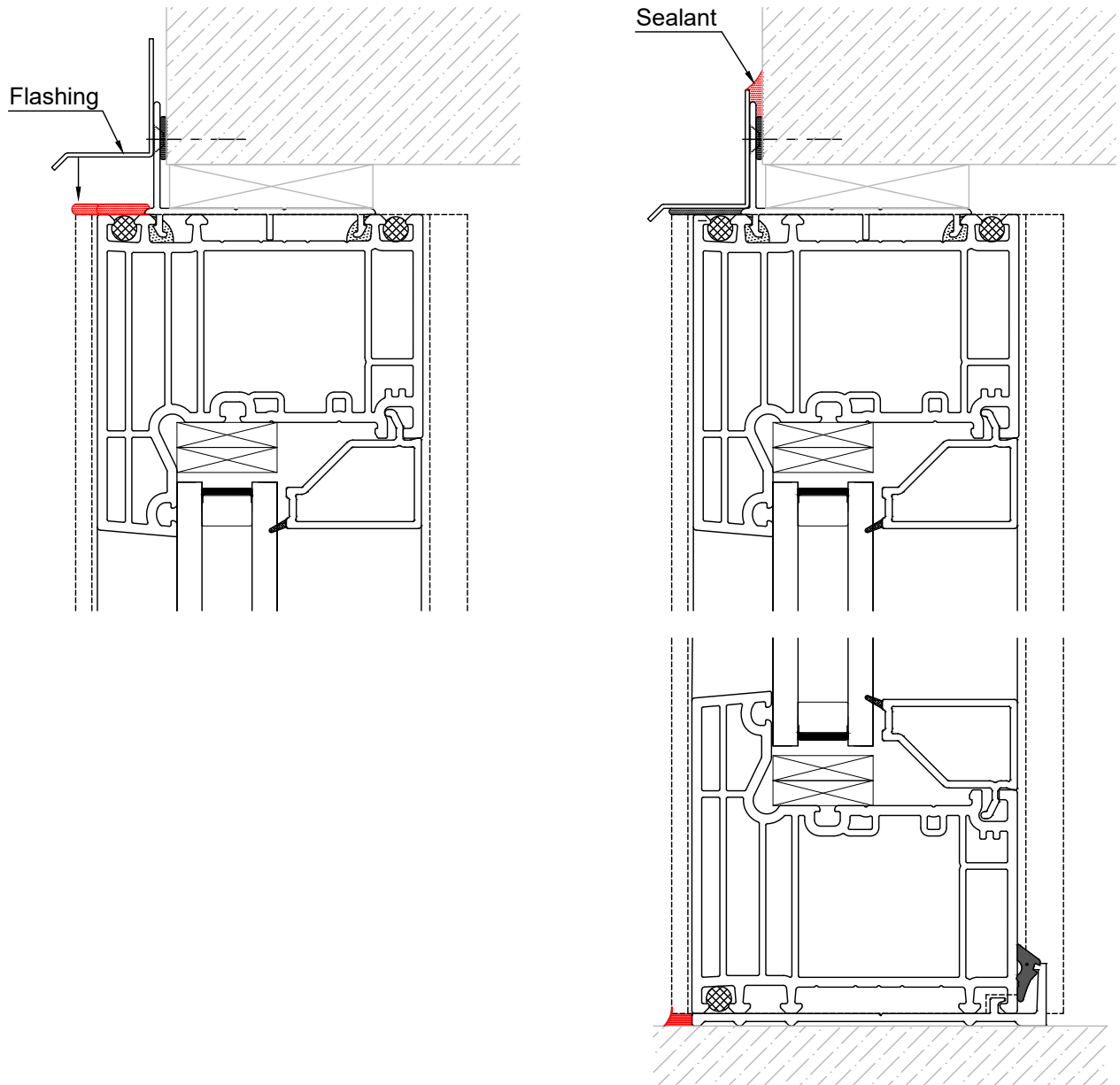

**This Completes the Door and Sidelite Frame Instruction Instructions**

# Weather Resistant Barrier Sealing Instructions

## WB1

Apply flashing tape at the sides of the window and door frames as shown. Extend tape a minimum of 1" past the Flashing Flange, but not more than the width of the flashing tape. Smooth the tape using a J-Roller.

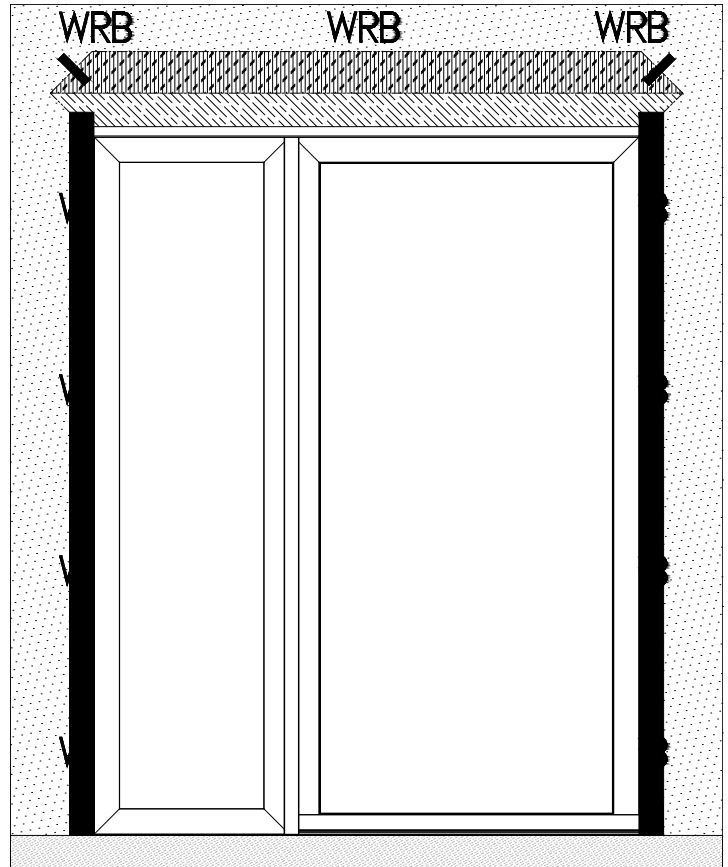

## WB2

Apply flashing tape at the top of the window and door frames as shown, overlapping the side flashing tape. Smooth the tape using a J-Roller. **Side flashing tape cannot extend above the top flashing tape. Doing so could result in product or property damage.**

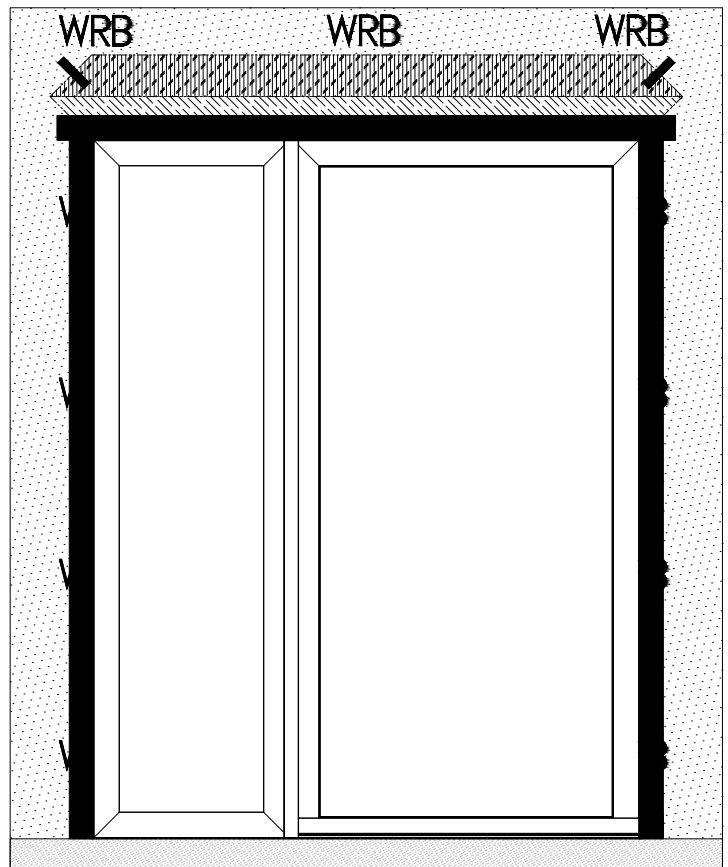

# WB3

Unfold the top flap of the wrap, and tape the angled seams as shown.  
Smooth the tape using a J-Roller. Insert insulation into the gap at the head and jambs as shown below.

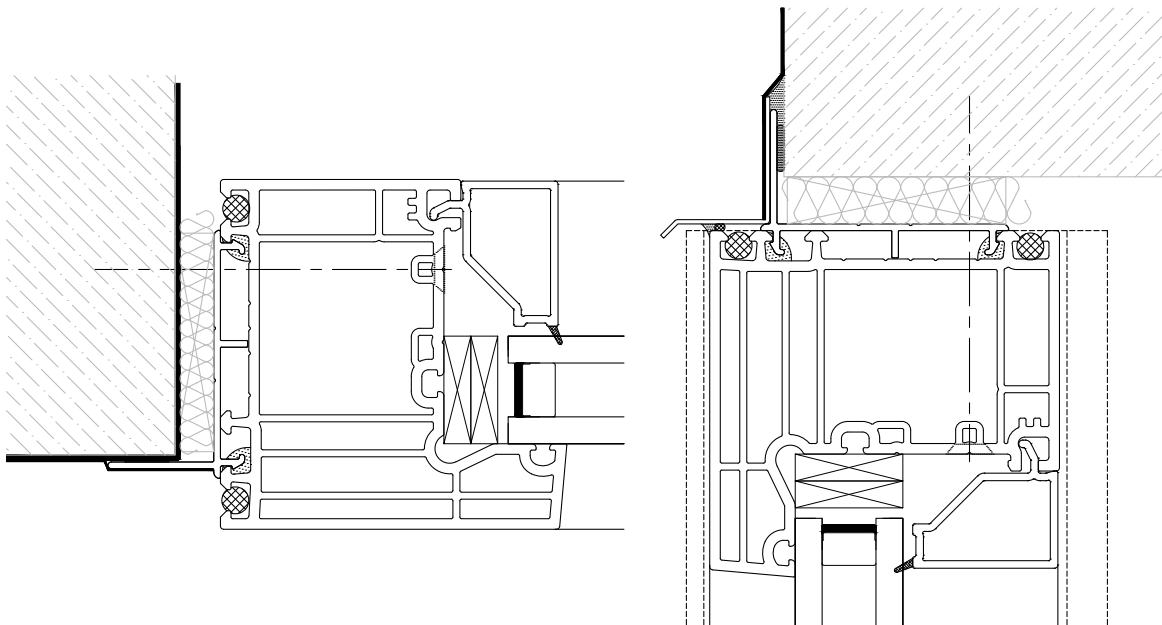
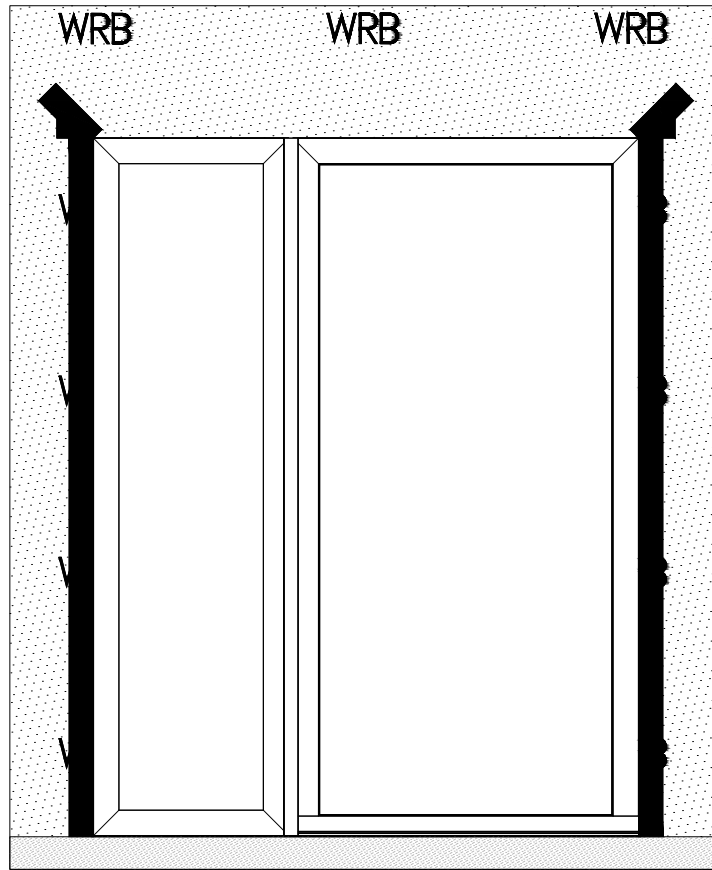

## WB4

Refer to the Shop Drawings if additional flashing or other material is required. After exterior building construction is completed, install back rod, then apply a continuous bead of sealant around entire perimeter of window frame and tool in place.

**Note:**

Installer to verify that Sealant being used is compatible with Quaker window frame and the surrounding building construction materials.

**Note:**

Please inform the exterior facade installer that they must maintain a minimum 1/4" gap between the facade material and the Window\Door Unit, and that the facade material should never come in contact with the Window Unit.

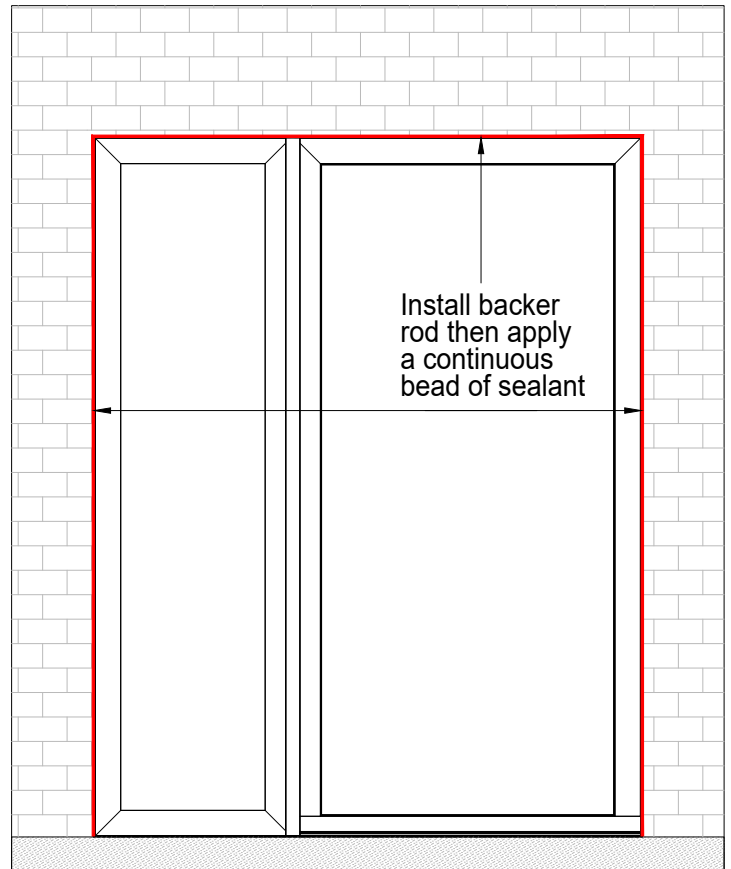

## WB5

At the interior jambs, peel back the Wedge Gasket at the sill. Insert a continuous backer rod at the jambs and head. Seal the window and T-Mullion to the building structure as shown below. Sealant should continue to the Sill Pan. Tool as needed then push the Wedge Gasket back into place.

**Note:**

Installer to verify that Sealant being used is compatible with Quaker window frame and the surrounding building construction materials.

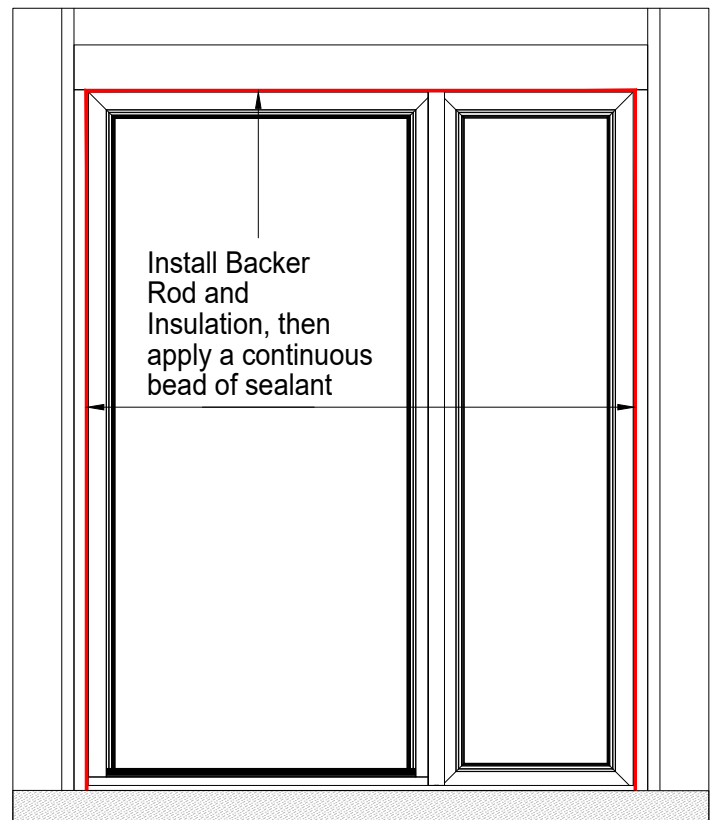
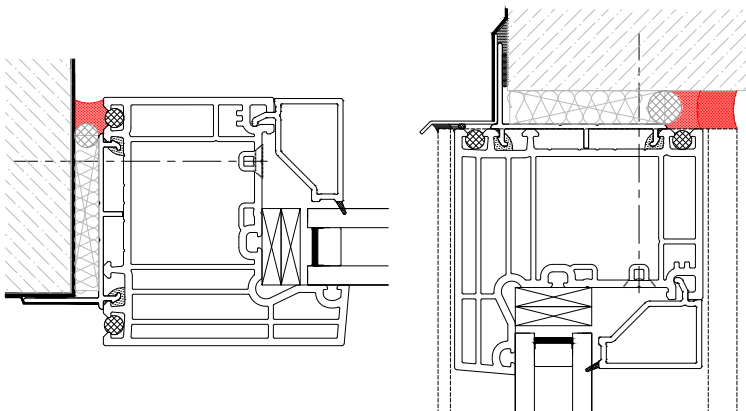

**This Completes the Weather Resistant Barrier Sealing Instructions**

## Liquid Barrier Instructions

### LB1

After the initial LBA has been applied, from the interior measure and verify the size of the rough opening. The rough opening should be  $\frac{3}{4}$ " wider and  $\frac{1}{2}$ " taller than the Total Unit size, unless otherwise specified on the shop drawings. Verify the rough opening is flat, plumb, level, and square. Take diagonal measurements to check for square. The sill structure beneath the unit must be level for proper unit operation.

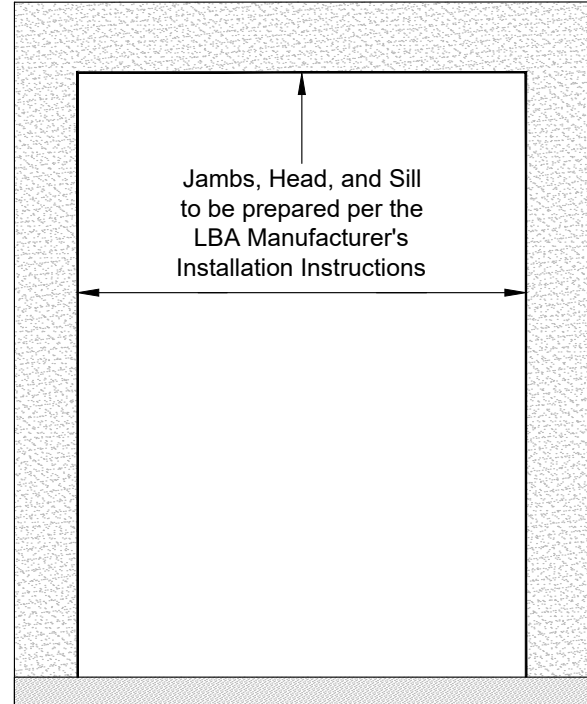
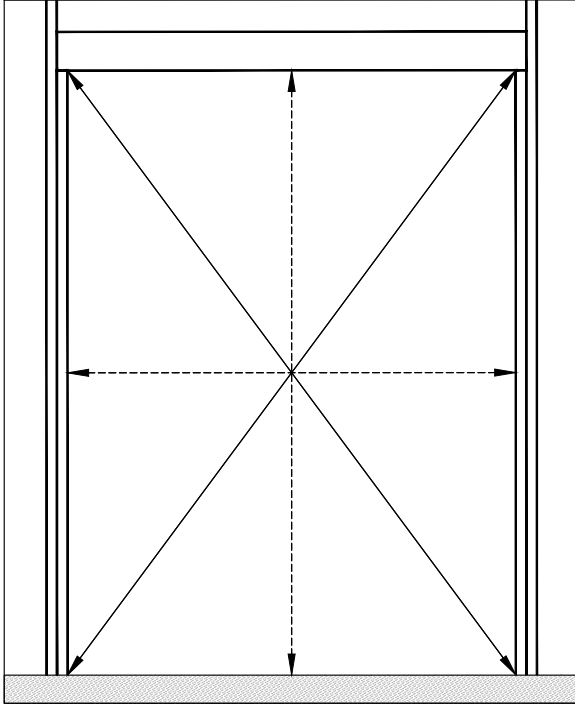

**Before proceeding to Instruction LB2, go to Instruction FF1 on page 7 and follow the installation thru Instruction FI17 on page 23.**

**These instructions will show WRB surrounds, but up to Instruction FI17, the Liquid Barrier installation will be the same. After Instruction FI17, proceed to Instruction LB2.**

# LB2

Apply a Liquid Barrier over the Flashing Flange and perimeter fasteners at the head and jams only.  
Liquid Barrier must be continuous and cover entire face as shown without any gaps or holes.  
Insert insulation into the gap at the head and jams as shown below.

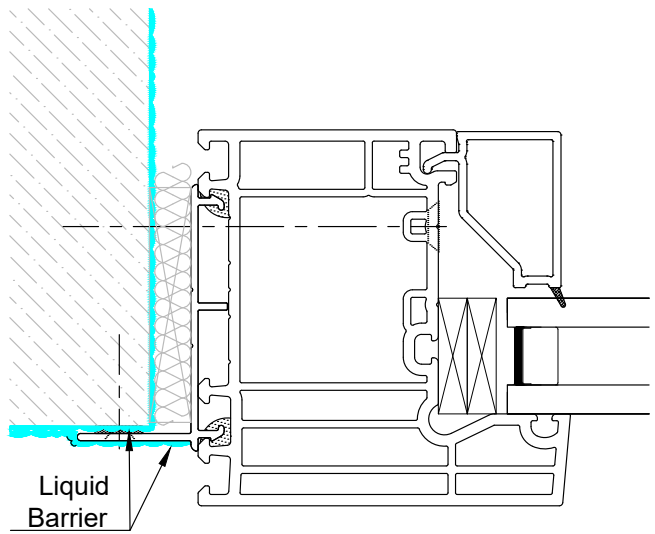
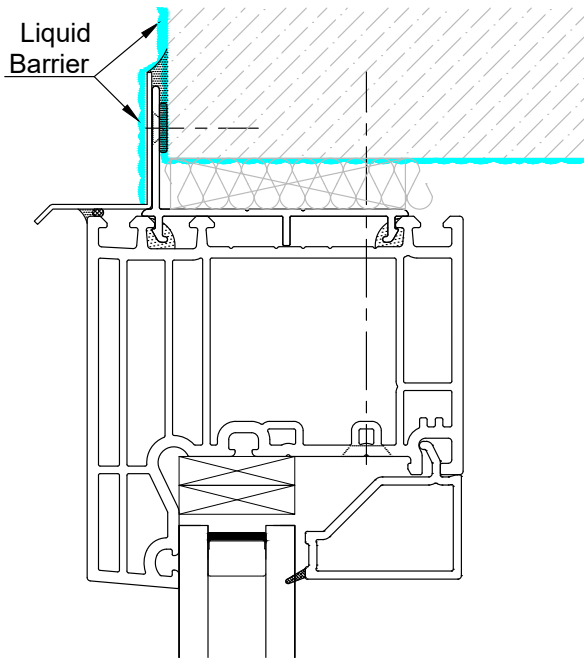
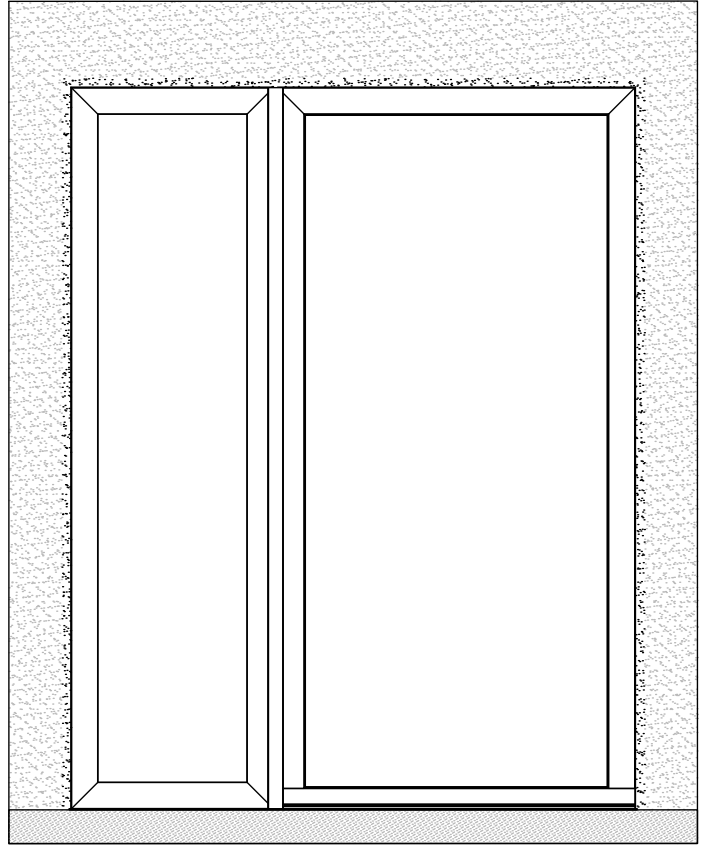
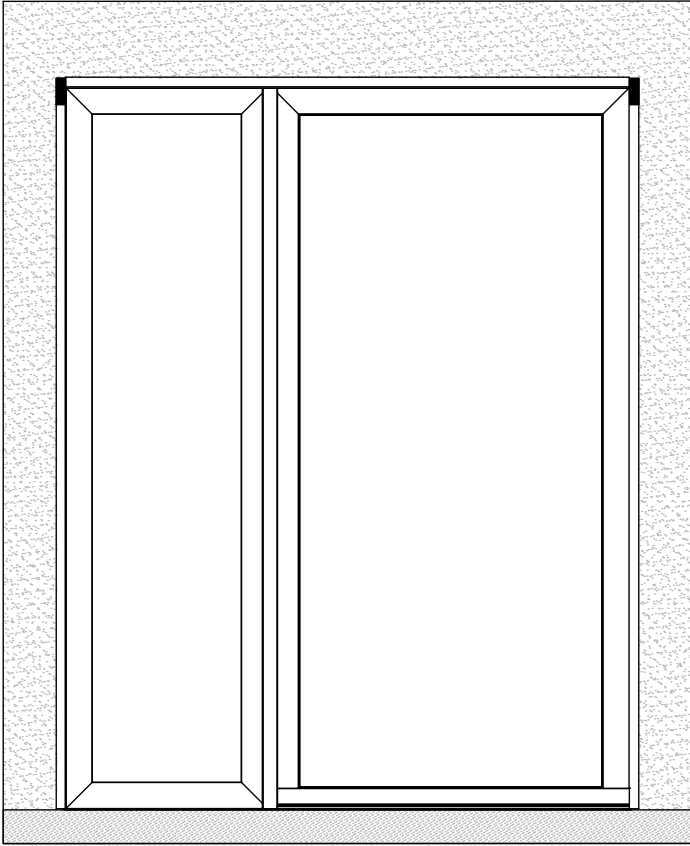

## LB3

Refer to the Shop Drawings if additional flashing or other material is required. After exterior building construction is completed, install back rod, then apply a continuous bead of sealant around entire perimeter of window frame and tool in place.

Note:

Installer to verify that Sealant being used is compatible with Quaker window frame and the surrounding building construction materials.

Note:

Please inform the exterior facade installer that they must maintain a minimum 1/4" gap between the facade material and the WindowDoor Unit, and that the facade material should never come in contact with the Window Unit.

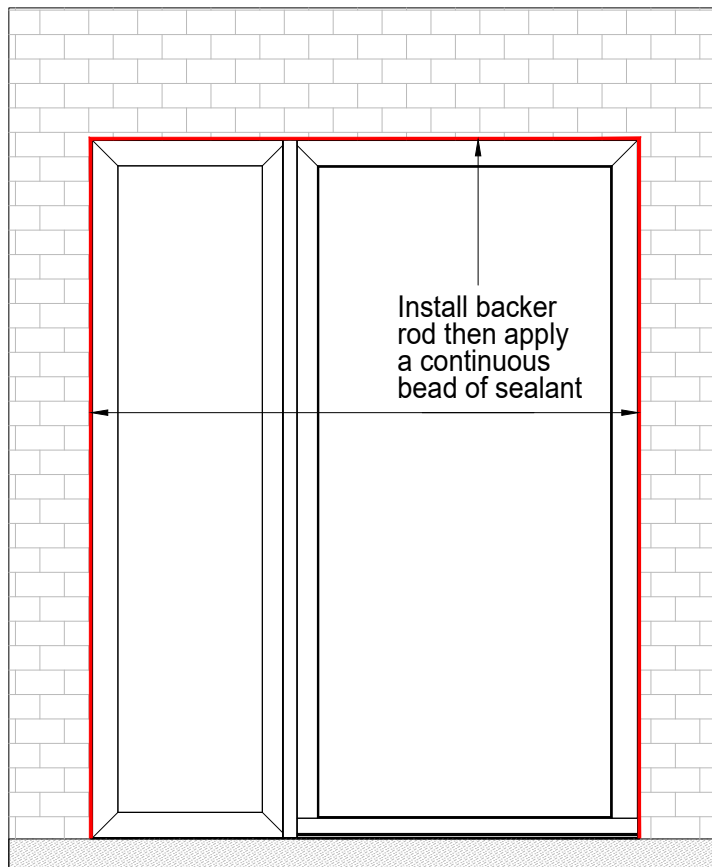

## LB4

At the interior jambs, peel back the Wedge Gasket at the sill. Insert a continuous backer rod at the jambs and head. Seal the window and T-Mullion to the building structure as shown below. Sealant should continue to the Sill Pan. Tool as needed then push the Wedge Gasket back into place.

Note:

Installer to verify that Sealant being used is compatible with Quaker window frame and the surrounding building construction materials.

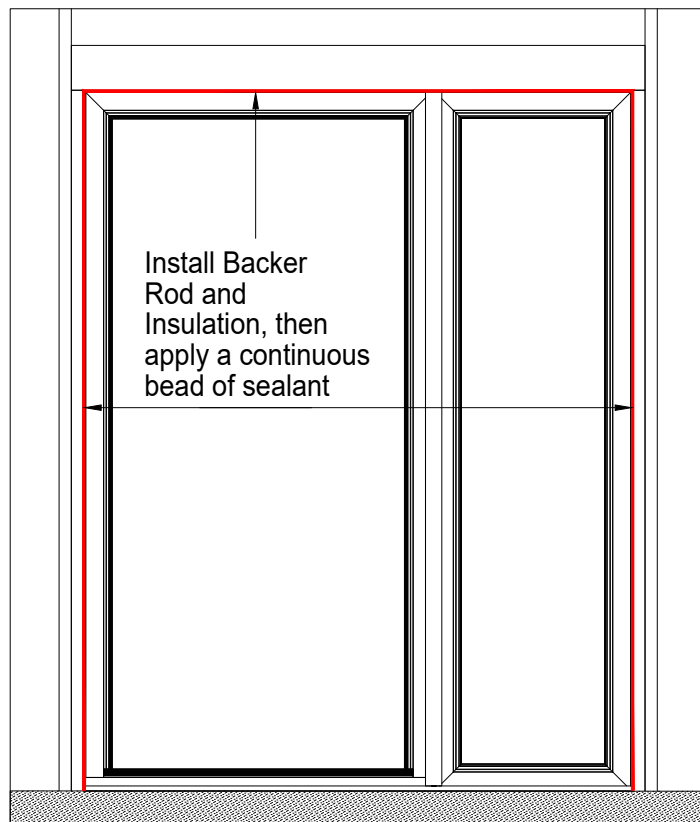
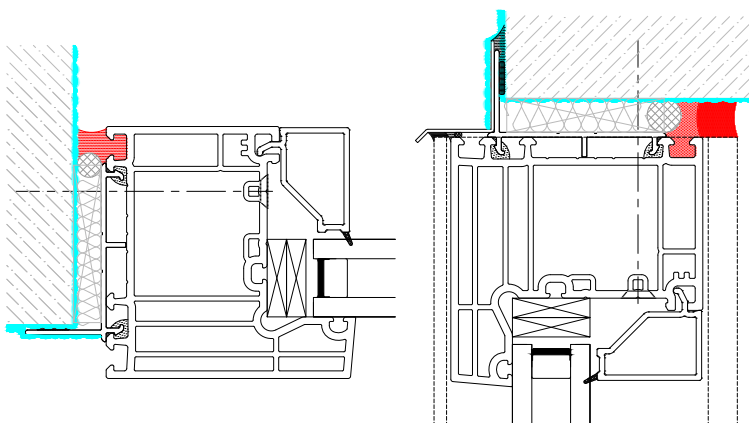

**This Completes the Liquid Barrier Sealing Instructions**

# Door Installation and Hinge Adjustment Instructions

At this time, lift the door onto the hinges. Adjust the door per the instructions below and on page 29. Verify locking is still aligned and works properly.

## Höhenverstellung · Réglage en hauteur · Adjusting the height

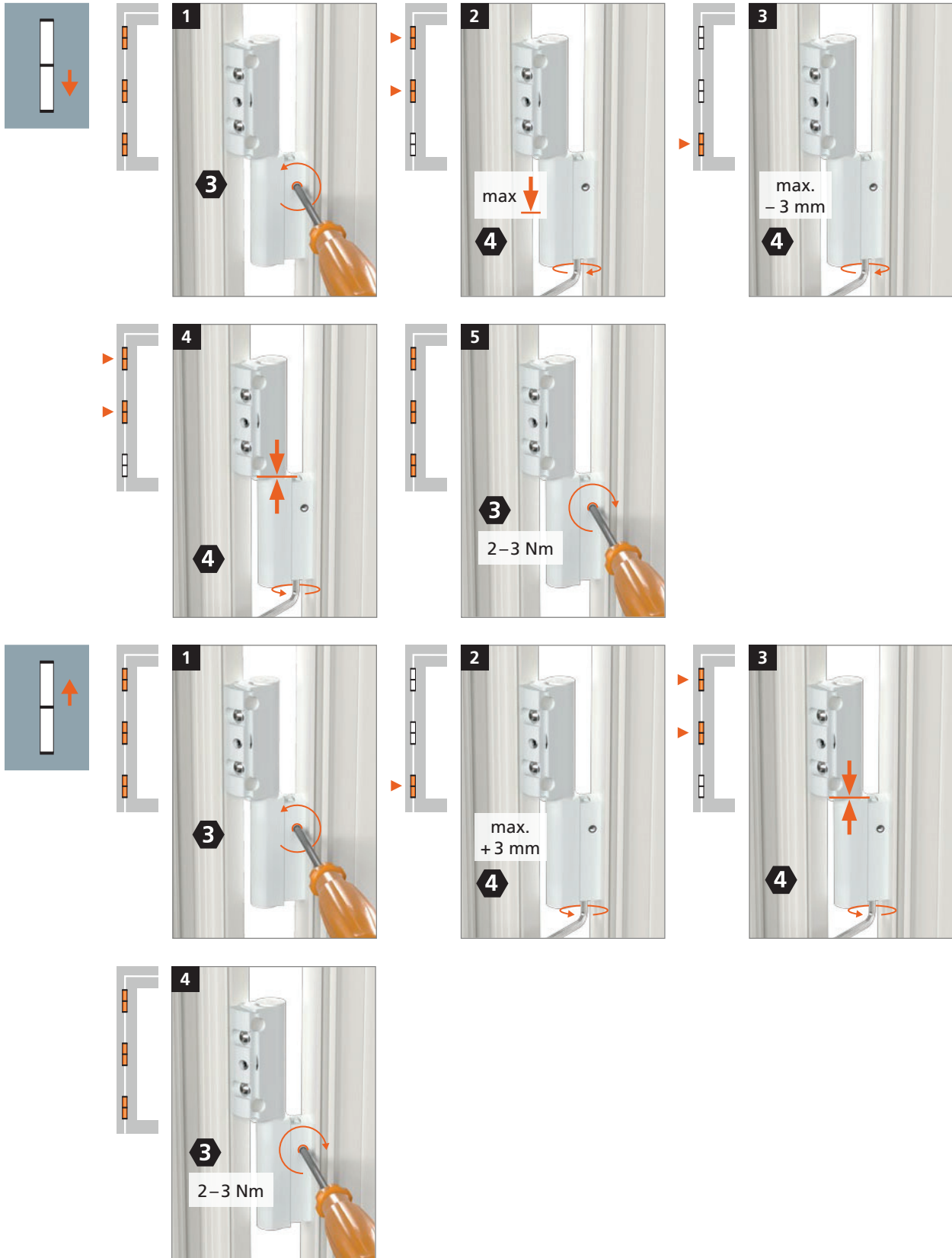

**Horizontalverstellung · Réglage horizontal · Horizontal adjustment**

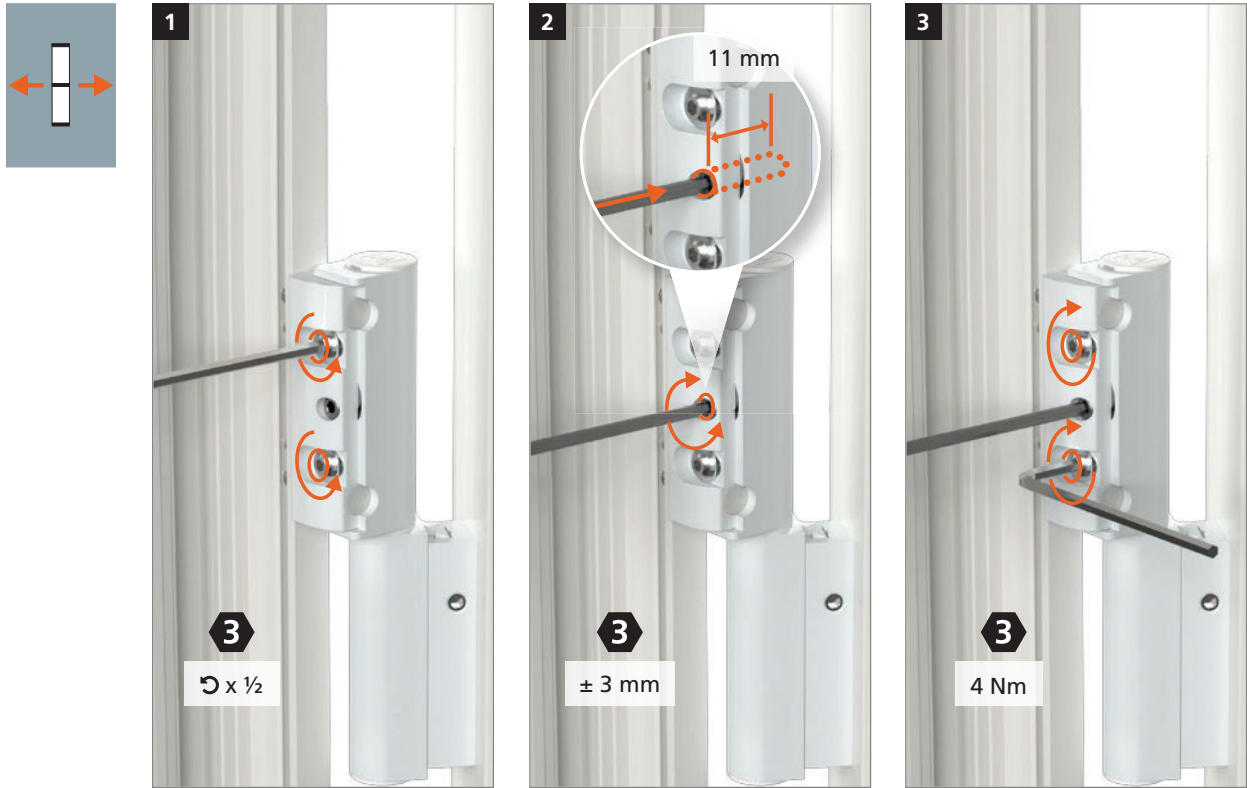

**Dichtungsandruckverstellung · Réglage de la compression du joint d'étanchéité · Adjusting the sealing pressure**

