



E500 Series Hung, Horizontal Slider, Fixed Vertical Mulls

All information seen within this document are considered current. However periodic changes/updates to our products are necessary. Quaker Window Products Inc. reserves the right to change any information without notice.



C-MULL
M6270

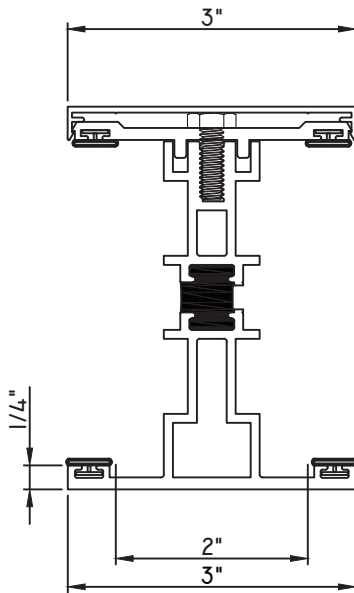

HEAVY WALL T-MULL

- M21045 - T-MULL
- M21043 - BASE
- M21044 - CAP
- BPN-9159 - W.S. (QTY. 4)
- MT1/4 20X5/8 - BOLTS (18" APROX. O.C.)
- M13404 - L-ANGLE (QTY. 2)
- MF8-15X7/8-8HD - FASTENERS (QTY. 2)
- MF8-15X1 1/2 - FASTENERS (QTY. 2)

**MUST BE USED WITH HEAVY WALL
3 1/4" RECEPTOR & SUBSILLS**

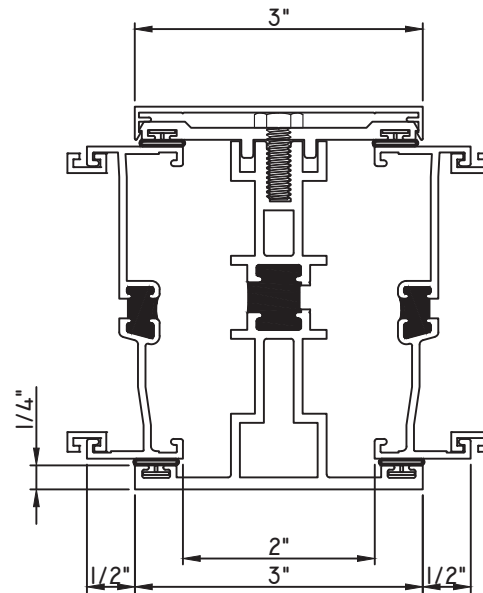

HEAVY WALL T-MULL/1" STACK MULL LEFT/RIGHT

- M21045 - T-MULL
- M21043 - BASE
- M21044 - CAP
- M21087 - 1" STACK MULL LEFT/RIGHT

SCALE 1:2

Our products are tested to the standards of and certified by some of the foremost organizations in the fenestration industry.





E500 Series Hung, Horizontal Slider, Fixed Vertical Mulls

All information seen within this document are considered current. However periodic changes/updates to our products are necessary. Quaker Window Products Inc. reserves the right to change any information without notice.



BULLNOSE T-MULL W/ 1 1/4" INTERIOR CAP

- M21086 - T-MULL
- M14895 - BASE
- M14896 - CAP
- BPN-9159 - W.S. (QTY. 4)
- MH1/4 20X3/4 - BOLTS (18" APROX. O.C.)
- M13404 - L-ANGLE (QTY. 2)
- MF8-15X7/8-8HD - FASTENERS (QTY. 2)
- MF8-15X1 1/2 - FASTENERS (QTY. 2)

**CAN'T BE USED WITH RECEPTOR &
SUBSILL INSTALLATION**

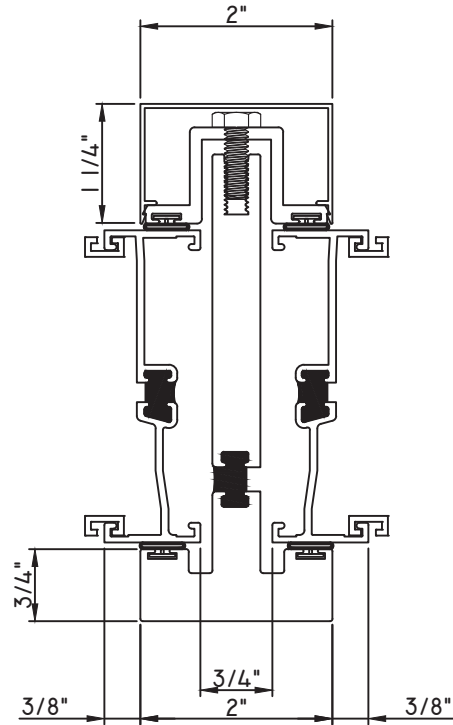

BULLNOSE T-MULL W/ 1 1/4" INTERIOR CAP / 1" STACK MULL LEFT/RIGHT

- M21086 - T-MULL
 - M14895 - BASE
 - M14896 - CAP
 - M21087 - 1" STACK MULL LEFT/RIGHT
- CAN'T BE USED WITH RECEPTOR &
SUBSILL INSTALLATION**

SCALE 1:2

Our products are tested to the standards of and certified by some of the foremost organizations in the fenestration industry.





E500 Series Hung, Horizontal Slider, Fixed Vertical Mulls

All information seen within this document are considered current. However periodic changes/updates to our products are necessary. Quaker Window Products Inc. reserves the right to change any information without notice.

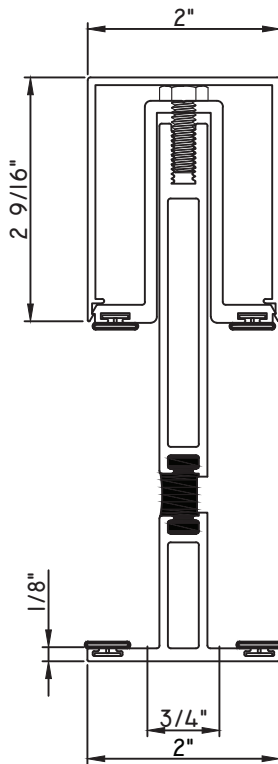

T-MULL W/ 2 9/16" INTERIOR CAP

- M21856 - T-MULL
- M21855 - BASE
- M21854 - CAP
- BPN-9159 - W.S. (QTY. 4)
- MH1/4 20X3/4 - BOLTS (18" APPROX. O.C.)
- M13404 - L-ANGLE (QTY. 2)
- MF8-15X7/8-8HD - FASTENERS (QTY. 2)
- MF8-15X1 1/2 - FASTENERS (QTY. 2)

**MUST BE USED WITH STANDARD
3 1/4" RECEPTOR & SUBSILLS**

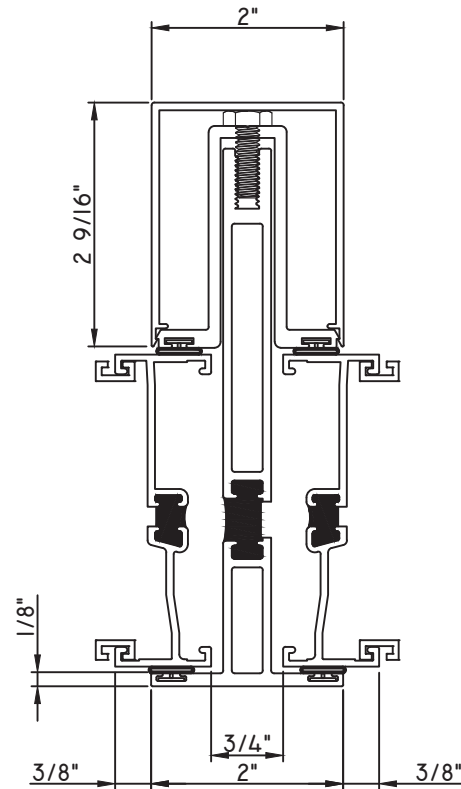

T-MULL W/ 2 9/16" INTERIOR CAP/ 1" STACK MULL LEFT

- M21856 - T-MULL
 - M21855 - BASE
 - M21854 - CAP
 - M21087 - 1" STACK MULL LEFT
- MUST BE USED WITH STANDARD
3 1/4" RECEPTOR & SUBSILLS**

SCALE 1:2

Our products are tested to the standards of and certified by some of the foremost organizations in the fenestration industry.





E500 Series Hung, Horizontal Slider, Fixed Vertical Mulls

All information seen within this document are considered current. However periodic changes/updates to our products are necessary. Quaker Window Products Inc. reserves the right to change any information without notice.

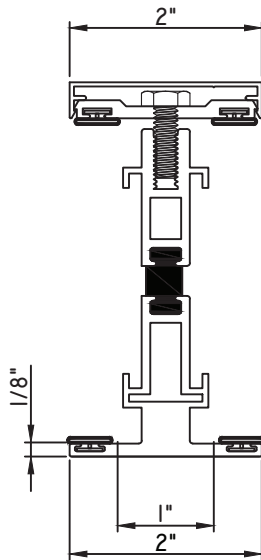

T-MULL

M22126 - T-MULL
MAX17386 - BASE
MAX14141 - CAP

BPN-9159 - W.S. (QTY. 4)
MH1/4 20X3/4 - BOLTS (18" APROX. O.C.)

PARTS FOR NON NAIL FIN INSTALL:

M13404 - L-ANGLE (QTY. 2)
MF8-15X7/8-8HD - FASTENERS (QTY. 2)
MF8-15X1 1/2 - FASTENERS (QTY. 2)

PARTS FOR NAIL FIN INSTALL:

M22127 - Z-CLIP (QTY. 2)
M23616 - H450 Z-CLIP (QTY. 2)

**MUST BE USED WITH STANDARD
3 1/4" RECEPTOR & SUBSILLS**

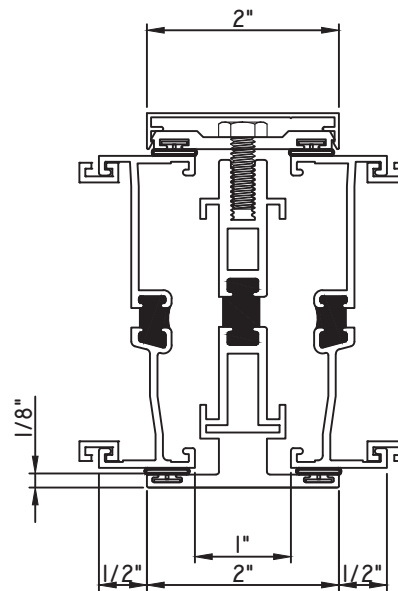

T-MULL/1" STACK MULL LEFT/RIGHT

M22126 - T-MULL
MAX17386 - BASE
MAX14141 - CAP

M21087 - 1" STACK MULL LEFT/RIGHT

**MUST BE USED WITH STANDARD
3 1/4" RECEPTOR & SUBSILLS**

SCALE 1:2

Our products are tested to the standards of and certified by some of the foremost organizations in the fenestration industry.





E500 Series Hung, Horizontal Slider, Fixed Vertical Mulls

All information seen within this document are considered current. However periodic changes/updates to our products are necessary. Quaker Window Products Inc. reserves the right to change any information without notice.

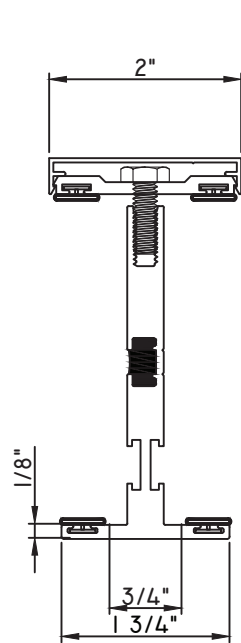

T-MULL

- M24628 - T-MULL
- MAX17386 - BASE
- MAX14141 - CAP
- BPN-9159 - W.S. (QTY. 4)
- MH1/4 20X3/4 - BOLTS (18" APROX. O.C.)
- PARTS FOR NON NAIL FIN INSTALL:
- M13404 - L-ANGLE (QTY. 2)
- MF8-15X7/8-8HD - FASTENERS (QTY. 2)
- MF8-15X1 1/2 - FASTENERS (QTY. 2)
- PARTS FOR NAIL FIN INSTALL:
- M22127 - Z-CLIP (QTY. 2)
- M23616 - H450 Z-CLIP (QTY. 2)

**MUST BE USED WITH STANDARD
3 1/4" RECEPTOR & SUBSILLS**

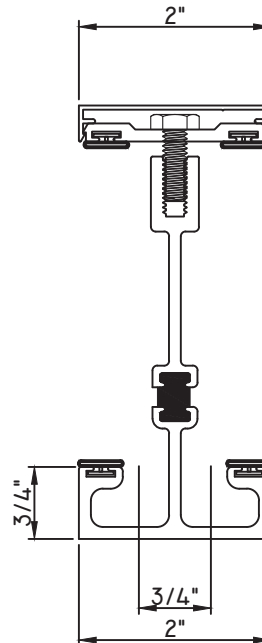

T-MULL

- M536203 - T-MULL
- M17386 - BASE
- MAX14141 - CAP
- BPN-9159 - W.S. (QTY. 4)
- MH1/4 20X3/4 - BOLTS (18" APROX. O.C.)
- M13404 - L-ANGLE (QTY. 2)
- MF8-15X7/8-8HD - FASTENERS (QTY. 2)
- MF8-15X1 1/2 - FASTENERS (QTY. 2)

**MUST BE USED WITH STANDARD
2 3/8" RECEPTOR & SUBSILL**

SCALE 1:2

Our products are tested to the standards of and certified by some of the foremost organizations in the fenestration industry.





E500 Series Hung, Horizontal Slider, Fixed Vertical Mulls

All information seen within this document are considered current. However periodic changes/updates to our products are necessary. Quaker Window Products Inc. reserves the right to change any information without notice.

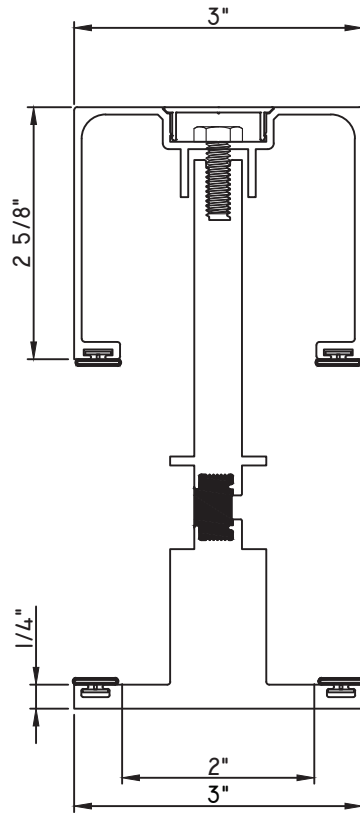

T-MULL

- M23980 - T-MULL
- M23981 - BASE
- M536207 - CAP
- BPN-9159 - W.S. (QTY. 4)
- MH1/4 20X3/4 - BOLTS (18" APROX. O.C.)
- M13404 - L-ANGLE (QTY. 2)
- MF8-15X7/8-8HD - FASTENERS (QTY. 2)
- MF8-15X1 1/2 - FASTENERS (QTY. 2)

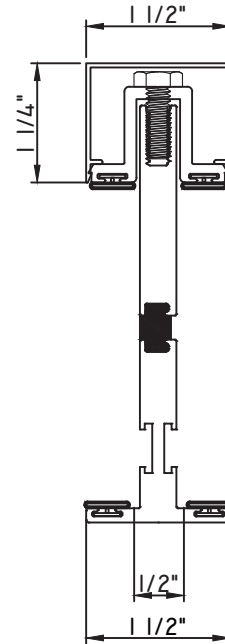

T-MULL

- M24500 - T-MULL (New Die)
- M234498 - BASE (New Die)
- M24499 - CAP (New Die)
- BPN-9159 - W.S. (QTY. 4)
- MH1/4 20X3/4 - BOLTS (18" APROX. O.C.)
- 5229-pc - ANCHOR (QTY. 2) (New Die)
- MPS-8X1 1/2 - FASTENERS (QTY. 2)

CAN ONLY BE USED WITH M600

SCALE 1:2

Our products are tested to the standards of and certified by some of the foremost organizations in the fenestration industry.





E500 Series Hung, Horizontal Slider, Fixed Stack Mulls

All information seen within this document are considered current. However periodic changes/updates to our products are necessary. Quaker Window Products Inc. reserves the right to change any information without notice.

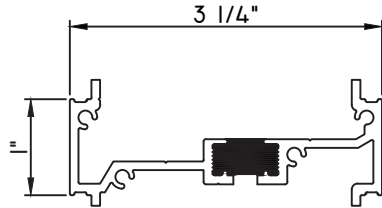

1" STACK MULL

M23723 - STACK MULL
1226-(COLOR REQUIRED) - WEEP COVER
QWP-M23723 - END DAM (QTY. 2)
M23845-PCS - M600 NAIL FIN END DAM
M23846-PCS - H450 NAIL FIN END DAM
MH8-18X1 LP - SCREW (QTY. 8)

FIELD APPLIED INSTALL ONLY

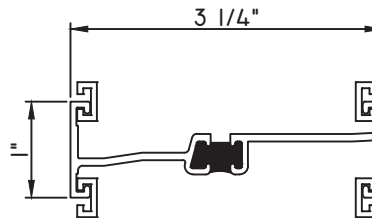

1" STACK MULL

M21087 - STACK MULL
M6270 - C-MULL (QTY. 2 OR 4)
1226-(COLOR REQUIRED) - WEEP COVE

FACTORY APPLIED INSTALL ONLY

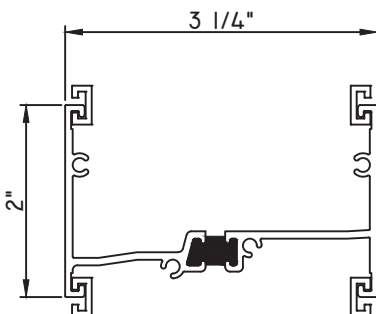

2" STACK MULL

M16318 - STACK MULL
M6270 - C-MULL (QTY. 2 OR 4)
72406 - END DAM (QTY. 2)
MH8-18X1 LP - SCREW (QTY. 8)
1226-(COLOR REQUIRED) - WEEP COVER

FACTORY APPLIED INSTALL ONLY

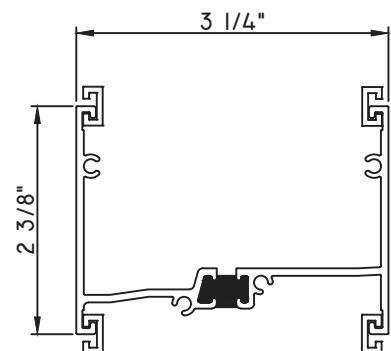

2 3/8" STACK MULL

M22015 - STACK MULL
M6270 - C-MULL (QTY. 2 OR 4)
QWP-032917 - END DAM (QTY. 2)
MH8-18X1 LP - SCREW (QTY. 8)
1226-(COLOR REQUIRED) - WEEP COVER

FACTORY APPLIED INSTALL ONLY

SCALE 1:2

Our products are tested to the standards of and certified by some of the foremost organizations in the fenestration industry.





E500 Series Hung, Horizontal Slider, Fixed Stack Mulls

All information seen within this document are considered current. However periodic changes/updates to our products are necessary. Quaker Window Products Inc. reserves the right to change any information without notice.

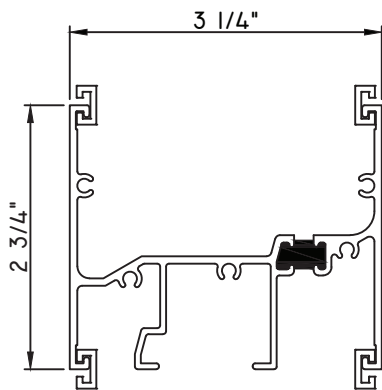

2 3/4" STACK MULL

- M15731 - STACK MULL
- M6270 - C-MULL (QTY. 2 OR 4)
- END DAM (QTY. 2)
- MH8-18X1 LP - SCREW (QTY. 8)
- 1226-(COLOR REQUIRED) - WEEP COVER

FACTORY APPLIED INSTALL ONLY

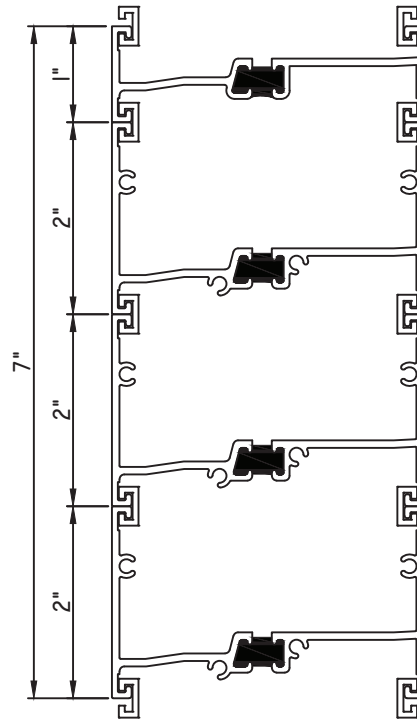

7" STACK MULL

- M16318 x3 - STACK MULL
- M6270 - C-MULL (QTY. 2 OR 4)
- 72406 - END DAM (QTY. 2)
- MH8-18X1 LP - SCREW (QTY. 8)
- 1226-(COLOR REQUIRED) - WEEP COVER

FACTORY APPLIED INSTALL ONLY

SCALE 1:2

Our products are tested to the standards of and certified by some of the foremost organizations in the fenestration industry.





E500 Series Hung, Horizontal Slider, Fixed Mull Covers

All information seen within this document are considered current. However periodic changes/updates to our products are necessary. Quaker Window Products Inc. reserves the right to change any information without notice.

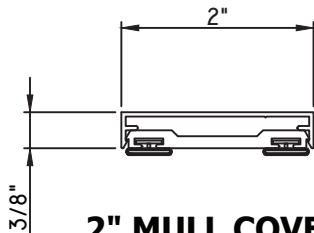

2" MULL COVER

MAX17386 - BASE
MAX14141 - CAP
BPN-9159 - W.S. (QTY. 2)

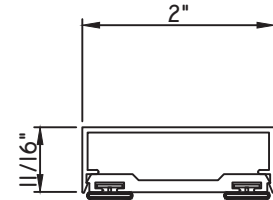

2" MULL COVER

MAX17386 - BASE
M23502 - CAP
BPN-9159 - W.S. (QTY. 2)

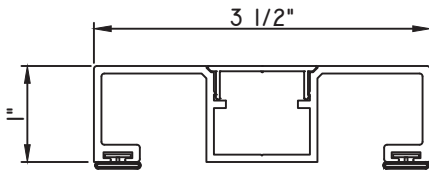

3 1/2" MULL COVER

M21664 - MULL COVER
M536207 - CAP
BPN-9159 - W.S. (QTY. 2)

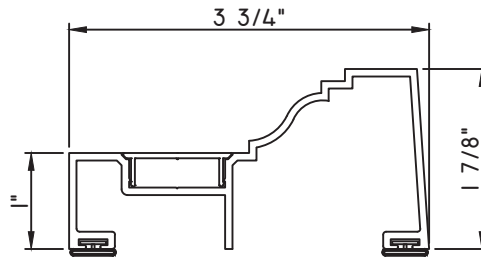

3 3/4" MULL COVER

M24837 - MULL COVER
M536207 - CAP
BPN-9159 - W.S. (QTY. 2)

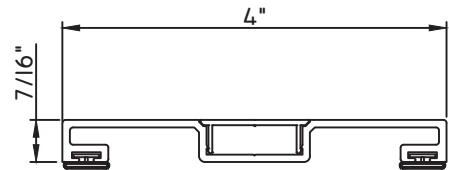

4" MULL COVER

M536208 - MULL COVER
M536207 - CAP
BPN-9159 - W.S. (QTY. 2)

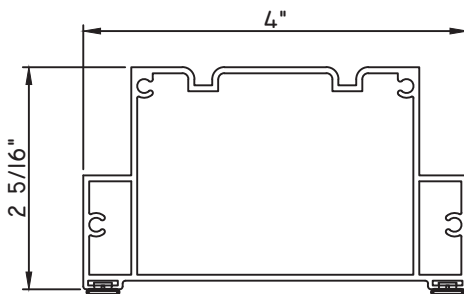

4" MULL COVER

M24428 - MULL COVER
BPN-9159 - W.S. (QTY. 2)
MH8-18X1 LP - SCREW (QTY. 8)

SCALE 1:2

Our products are tested to the standards of and certified by some of the foremost organizations in the fenestration industry.





E500 Series Hung, Horizontal Slider, Fixed Mull Covers

All information seen within this document are considered current. However periodic changes/updates to our products are necessary. Quaker Window Products Inc. reserves the right to change any information without notice.

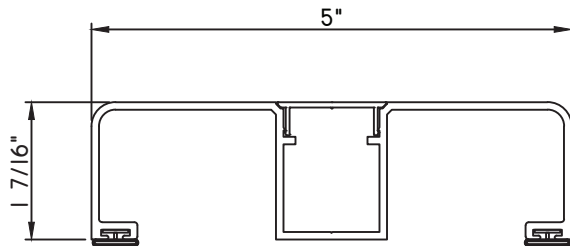

5 " MULL COVER

M23978 - MULL COVER
M536207 - CAP
BPN-9159 - W.S. (QTY. 2)

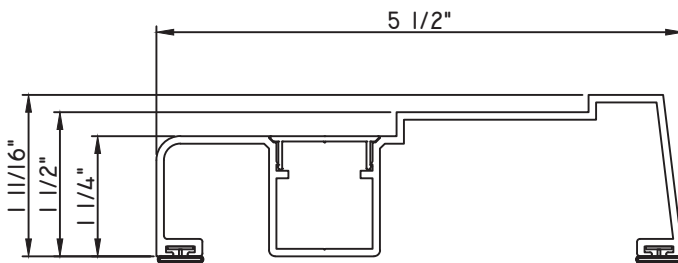

5 1/2" MULL COVER

M23979 - MULL COVER
M536207 - CAP
BPN-9159 - W.S. (QTY. 2)

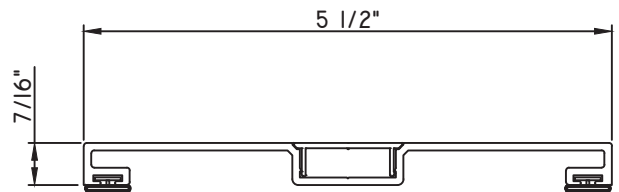

5 1/2" MULL COVER

M536206 - MULL COVER
M536207 - CAP
BPN-9159 - W.S. (QTY. 2)

SCALE 1:2

Our products are tested to the standards of and certified by some of the foremost organizations in the fenestration industry.





E500 Series Hung, Horizontal Slider, Fixed Mull Covers

All information seen within this document are considered current. However periodic changes/updates to our products are necessary. Quaker Window Products Inc. reserves the right to change any information without notice.

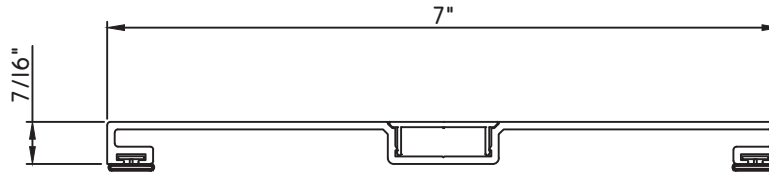

7" MULL COVER
M12794 - MULL COVER
M536207 - CAP
BPN-9159 - W.S. (QTY. 2)

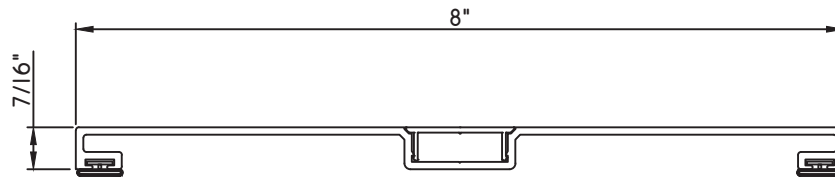

8" MULL COVER
M23410 - MULL COVER
M536207 - CAP
BPN-9159 - W.S. (QTY. 2)

SCALE 1:2

Our products are tested to the standards of and certified by some of the foremost organizations in the fenestration industry.

