

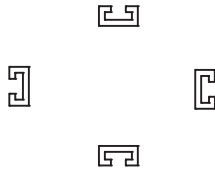

H450 Series Casement, Project-Out, Fixed Vertical Mulls

All information seen within this document are considered current. However periodic changes/updates to our products are necessary. Quaker Window Products Inc. reserves the right to change any information without notice.



C-MULL M6270

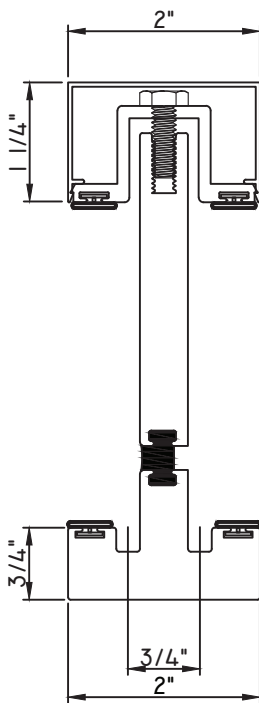

BULLNOSE T-MULL W/ 1 1/4" INTERIOR CAP

M21086 - T-MULL
M14895 - BASE
M14896 - CAP

BPN-9159 - W.S. (QTY. 4)
MH1/4 20X3/4 - BOLTS (18" APROX. O.C.)
M13404 - L-ANGLE (QTY. 2)
MF8-15X7/8-8HD - FASTENERS (QTY. 2)
MF8-15X1 1/2 - FASTENERS (QTY. 2)

**CAN'T BE USED WITH RECEPTOR &
SUBSILL INSTALLATION**

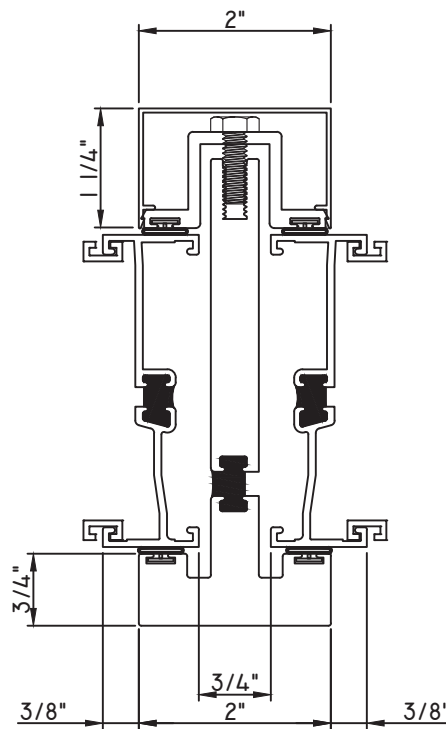

BULLNOSE T-MULL W/ 1 1/4" INTERIOR CAP / 1" STACK MULL LEFT/RIGHT

M21086 - T-MULL
M14895 - BASE
M14896 - CAP

M21087 - 1" STACK MULL LEFT/RIGHT
**CAN'T BE USED WITH RECEPTOR &
SUBSILL INSTALLATION**

Our products are tested to the standards of and certified by some of the foremost organizations in the fenestration industry.





H450 Series Casement, Project-Out, Fixed Vertical Mulls

All information seen within this document are considered current. However periodic changes/updates to our products are necessary. Quaker Window Products Inc. reserves the right to change any information without notice.

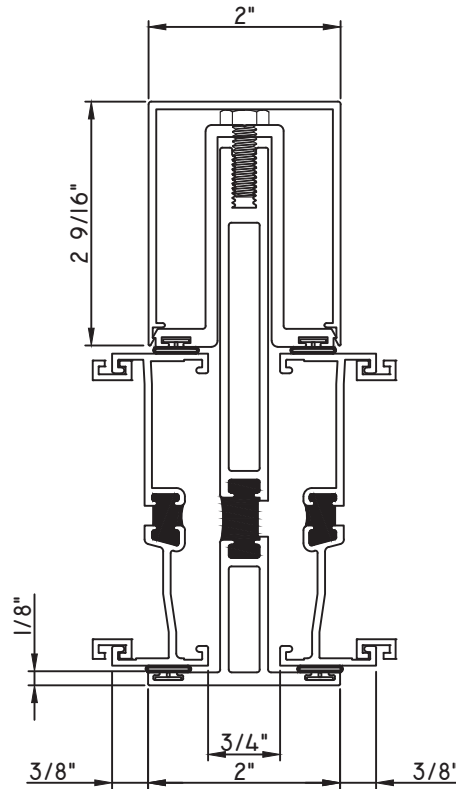
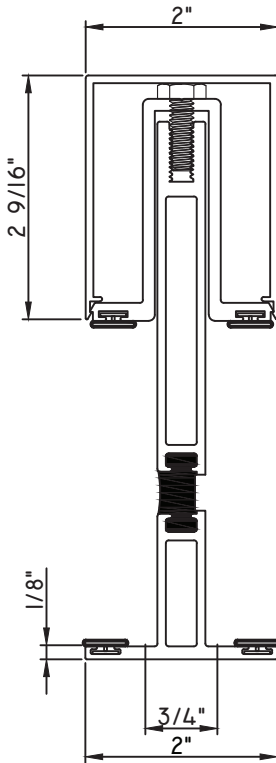

T-MULL W/ 2 9/16" INTERIOR CAP

- M21856 - T-MULL
- M21855 - BASE
- M21854 - CAP
- BPN-9159 - W.S. (QTY. 4)
- MH1/4 20X3/4 - BOLTS (18" APPROX. O.C.)
- M13404 - L-ANGLE (QTY. 2)
- MF8-15X7/8-8HD - FASTENERS (QTY. 2)
- MF8-15X1 1/2 - FASTENERS (QTY. 2)

**MUST BE USED WITH STANDARD
3 1/4" RECEPTOR & SUBSILLS**

T-MULL W/ 2 9/16" INTERIOR CAP/ 1" STACK MULL LEFT

- M21856 - T-MULL
 - M21855 - BASE
 - M21854 - CAP
 - M21087 - 1" STACK MULL LEFT
- MUST BE USED WITH STANDARD
3 1/4" RECEPTOR & SUBSILLS**

SCALE 1:2

Our products are tested to the standards of and certified by some of the foremost organizations in the fenestration industry.





H450 Series Casement, Project-Out, Fixed Vertical Mulls

All information seen within this document are considered current. However periodic changes/updates to our products are necessary. Quaker Window Products Inc. reserves the right to change any information without notice.

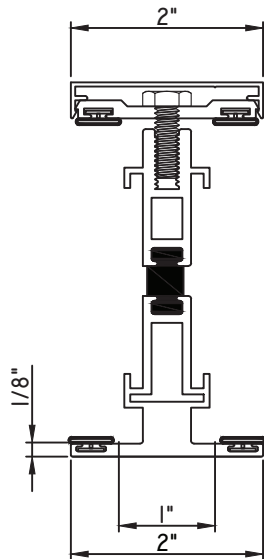

T-MULL

- M22126 - T-MULL
- MAX17386 - BASE
- MAX14141 - CAP
- BPN-9159 - W.S. (QTY. 4)
- MH1/4 20X3/4 - BOLTS (18" APROX. O.C.)
- PARTS FOR NON NAIL FIN INSTALL:
- M13404 - L-ANGLE (QTY. 2)
- MF8-15X7/8-8HD - FASTENERS (QTY. 2)
- MF8-15X1 1/2 - FASTENERS (QTY. 2)
- PARTS FOR NAIL FIN INSTALL:
- M22127 - Z-CLIP (QTY. 2)
- M23616 - H450 Z-CLIP (QTY. 2)

**MUST BE USED WITH STANDARD
3 1/4" RECEPTOR & SUBSILLS**

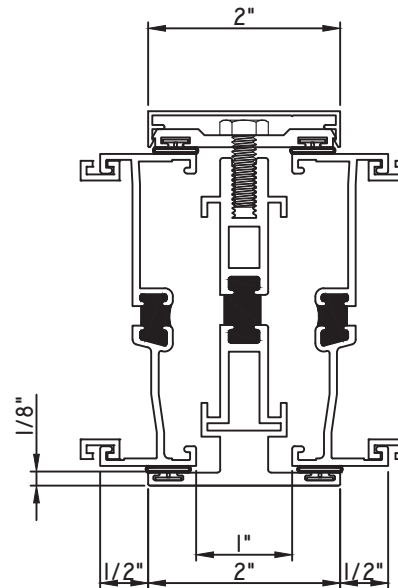

T-MULL/1" STACK MULL LEFT/RIGHT

- M22126 - T-MULL
- MAX17386 - BASE
- MAX14141 - CAP
- M21087 - 1" STACK MULL LEFT/RIGHT

**MUST BE USED WITH STANDARD
3 1/4" RECEPTOR & SUBSILLS**

SCALE 1:2

Our products are tested to the standards of and certified by some of the foremost organizations in the fenestration industry.





H450 Series Casement, Project-Out, Fixed Vertical Mulls

All information seen within this document are considered current. However periodic changes/updates to our products are necessary. Quaker Window Products Inc. reserves the right to change any information without notice.

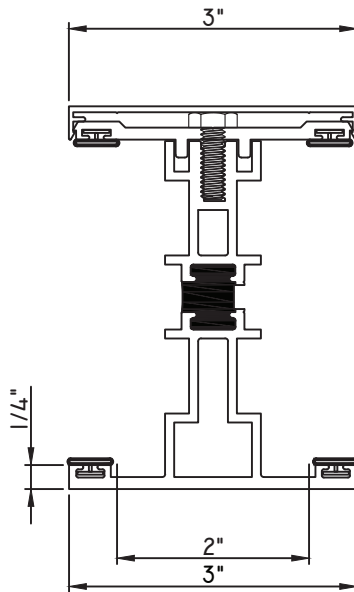

HEAVY WALL T-MULL

- M21045 - T-MULL
- M21043 - BASE
- M21044 - CAP
- BPN-9159 - W.S. (QTY. 4)
- MT1/4 20X5/8 - BOLTS (18" APROX. O.C.)
- M13404 - L-ANGLE (QTY. 2)
- MF8-15X7/8-8HD - FASTENERS (QTY. 2)
- MF8-15X1 1/2 - FASTENERS (QTY. 2)

**MUST BE USED WITH HEAVY WALL
3 1/4" RECEPTOR & SUBSILLS**

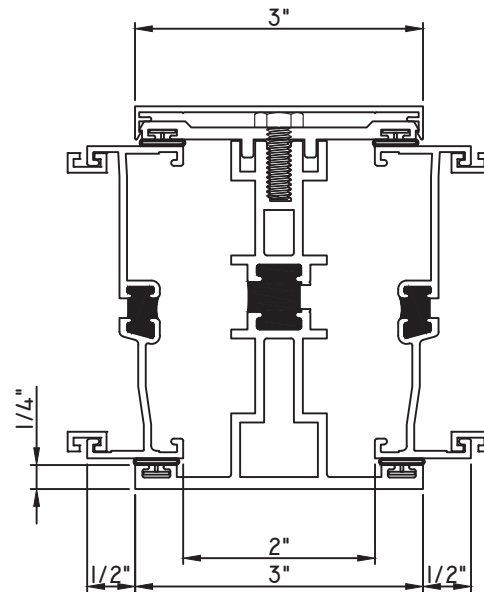

HEAVY WALL T-MULL/1" STACK MULL LEFT/RIGHT

- M21045 - T-MULL
- M21043 - BASE
- M21044 - CAP
- M21087 - 1" STACK MULL LEFT/RIGHT

SCALE 1:2

Our products are tested to the standards of and certified by some of the foremost organizations in the fenestration industry.





H450 Series Casement, Project-Out, Fixed Vertical Mulls

All information seen within this document are considered current. However periodic changes/updates to our products are necessary. Quaker Window Products Inc. reserves the right to change any information without notice.

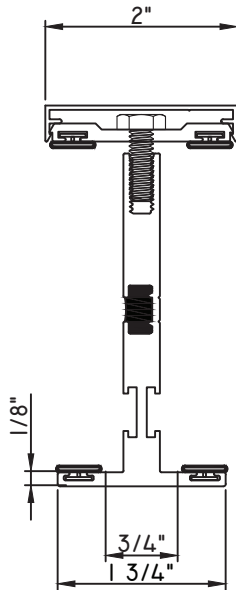

T-MULL

M24628 - T-MULL
MAX17386 - BASE
MAX14141 - CAP

BPN-9159 - W.S. (QTY. 4)

MH1/4 20X3/4 - BOLTS (18" APROX. O.C.)

PARTS FOR NON NAIL FIN INSTALL:

M13404 - L-ANGLE (QTY. 2)

MF8-15X7/8-8HD - FASTENERS (QTY. 2)

MF8-15X1 1/2 - FASTENERS (QTY. 2)

PARTS FOR NAIL FIN INSTALL:

M22127 - Z-CLIP (QTY. 2)

M23616 - H450 Z-CLIP (QTY. 2)

**MUST BE USED WITH STANDARD
3 1/4" RECEPTOR & SUBSILLS**

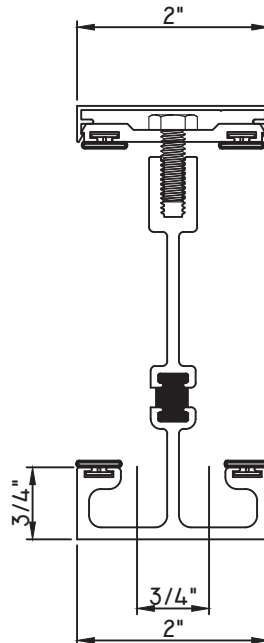

T-MULL

M536203 - T-MULL
M17386 - BASE
MAX14141 - CAP

BPN-9159 - W.S. (QTY. 4)

MH1/4 20X3/4 - BOLTS (18" APROX. O.C.)

M13404 - L-ANGLE (QTY. 2)

MF8-15X7/8-8HD - FASTENERS (QTY. 2)

MF8-15X1 1/2 - FASTENERS (QTY. 2)

**MUST BE USED WITH STANDARD
2 3/8" RECEPTOR & SUBSILL**

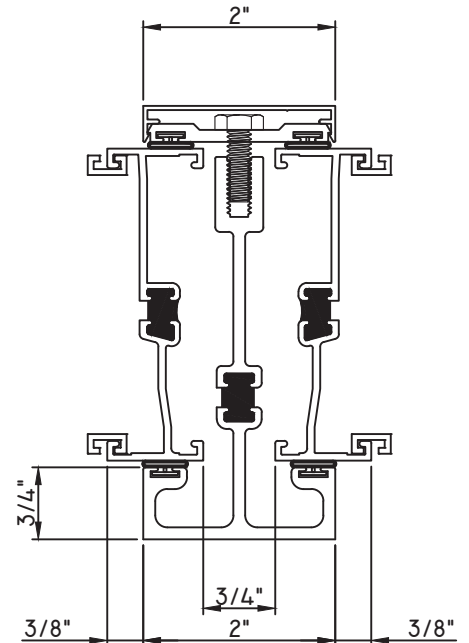

T-MULL/1" STACK MULL LEFT/RIGHT

M536203 - T-MULL

M17386 - BASE

MAX14141 - CAP

M21087 - 1" STACK MULL LEFT/RIGHT

**MUST BE USED WITH STANDARD
2 3/8" RECEPTOR & SUBSILL**

SCALE 1:2

Our products are tested to the standards of and certified by some of the foremost organizations in the fenestration industry.





H450 Series Casement, Project-Out, Fixed Vertical Mulls

All information seen within this document are considered current. However periodic changes/updates to our products are necessary. Quaker Window Products Inc. reserves the right to change any information without notice.

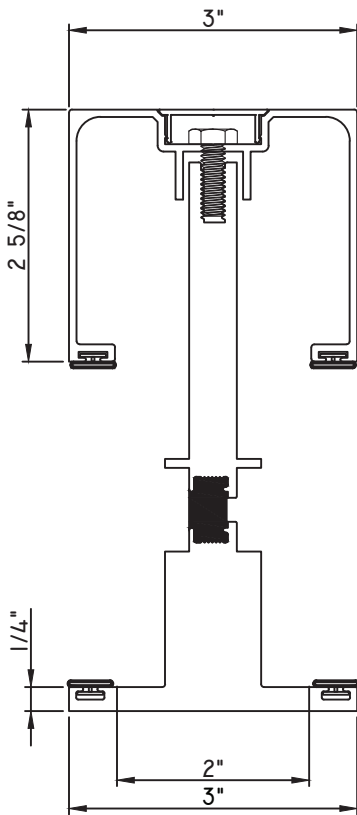

T-MULL

- M23980 - T-MULL
- M23981 - BASE
- M536207 - CAP
- BPN-9159 - W.S. (QTY. 4)
- MH1/4 20X3/4 - BOLTS (18" APROX. O.C.)
- M13404 - L-ANGLE (QTY. 2)
- MF8-15X7/8-8HD - FASTENERS (QTY. 2)
- MF8-15X1 1/2 - FASTENERS (QTY. 2)

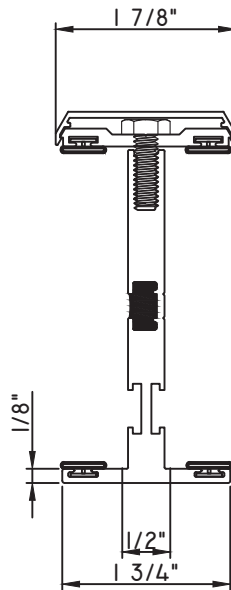

T-MULL

- M24628 - T-MULL
- M23056 - BASE
- M23058 - CAP
- BPN-9159 - W.S. (QTY. 4)
- MH1/4 20X3/4 - BOLTS (18" APROX. O.C.)
- PARTS FOR NON NAIL FIN INSTALL:
- M13404 - L-ANGLE (QTY. 2)
- MF8-15X7/8-8HD - FASTENERS (QTY. 2)
- MF8-15X1 1/2 - FASTENERS (QTY. 2)
- PARTS FOR NAIL FIN INSTALL:
- M22127 - Z-CLIP (QTY. 2)
- M23616 - H450 Z-CLIP (QTY. 2)

**MUST BE USED WITH STANDARD
3 1/4" RECEPTOR & SUBSILLS**

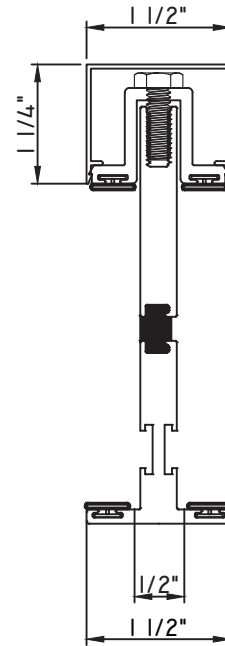

T-MULL

- M24500 - T-MULL (New Die)
- M234498 - BASE (New Die)
- M24499 - CAP (New Die)
- BPN-9159 - W.S. (QTY. 4)
- MH1/4 20X3/4 - BOLTS (18" APROX. O.C.)
- 5229-pc - ANCHOR (QTY. 2) (New Die)
- MPS-8X1 1/2 - FASTENERS (QTY. 2)

CAN ONLY BE USED WITH M600

SCALE 1:2

Our products are tested to the standards of and certified by some of the foremost organizations in the fenestration industry.





H450 Series Casement, Project-Out, Fixed Horizontal Stack Mulls

All information seen within this document are considered current. However periodic changes/updates to our products are necessary. Quaker Window Products Inc. reserves the right to change any information without notice.

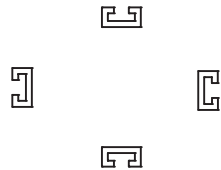

C-MULL
M6270

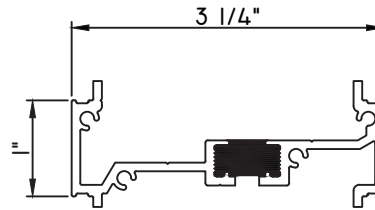

1" STACK MULL

- M23723 - STACK MULL
- 1226-(COLOR REQUIRED) - WEEP COVER
- QWP-M23723 - END DAM (QTY. 2)
- M23845-PCS - M600 NAIL FIN END DAM
- M23846-PCS - H450 NAIL FIN END DAM
- MH8-18X1 LP - SCREW (QTY. 8)

FIELD APPLIED INSTALL ONLY

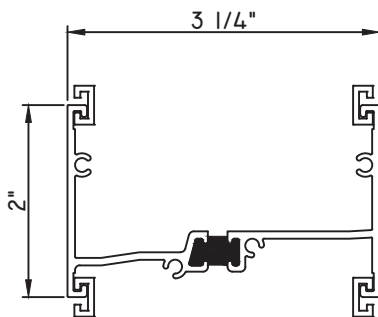

2" STACK MULL

- M16318 - STACK MULL
- M6270 - C-MULL (QTY. 2 OR 4)
- 72406 - END DAM (QTY. 2)
- MH8-18X1 LP - SCREW (QTY. 8)
- 1226-(COLOR REQUIRED) - WEEP COVER

FACTORY APPLIED INSTALL ONLY

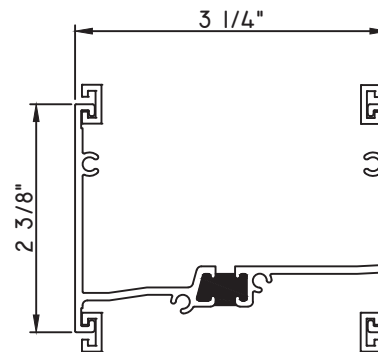

2 3/8" STACK MULL

- M22015 - STACK MULL
- M6270 - C-MULL (QTY. 2 OR 4)
- QWP-032917 - END DAM (QTY. 2)
- MH8-18X1 LP - SCREW (QTY. 8)
- 1226-(COLOR REQUIRED) - WEEP COVER

FACTORY APPLIED INSTALL ONLY

SCALE 1:2

Our products are tested to the standards of and certified by some of the foremost organizations in the fenestration industry.





H450 Series Casement, Project-Out, Fixed Horizontal Stack Mulls

All information seen within this document are considered current. However periodic changes/updates to our products are necessary. Quaker Window Products Inc. reserves the right to change any information without notice.

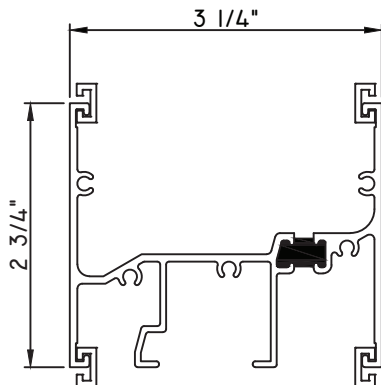

2 3/4" STACK MULL

M15731 - STACK MULL
M6270 - C-MULL (QTY. 2 OR 4)
- END DAM (QTY. 2)
MH8-18X1 LP - SCREW (QTY. 8)
1226-(COLOR REQUIRED) - WEEP COVER

FACTORY APPLIED INSTALL ONLY

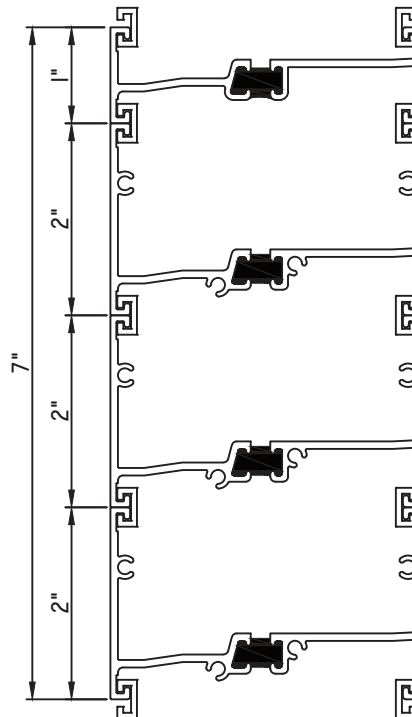

7" STACK MULL

M16318 x3 - STACK MULL
M6270 - C-MULL (QTY. 2 OR 4)
72406 - END DAM (QTY. 2)
MH8-18X1 LP - SCREW (QTY. 8)
1226-(COLOR REQUIRED) - WEEP COVER

FACTORY APPLIED INSTALL ONLY

SCALE 1:2

Our products are tested to the standards of and certified by some of the foremost organizations in the fenestration industry.





H450 Series Casement, Project-Out, Fixed Mull Covers

All information seen within this document are considered current. However periodic changes/updates to our products are necessary. Quaker Window Products Inc. reserves the right to change any information without notice.

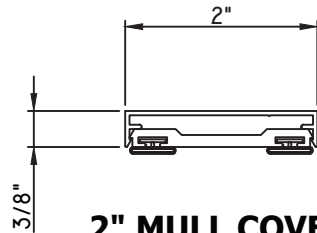

2" MULL COVER

MAX17386 - BASE
MAX14141 - CAP
BPN-9159 - W.S. (QTY. 2)

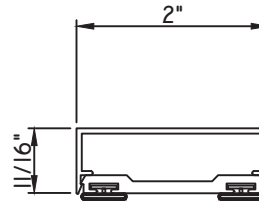

2" MULL COVER

MAX17386 - BASE
M23502 - CAP
BPN-9159 - W.S. (QTY. 2)

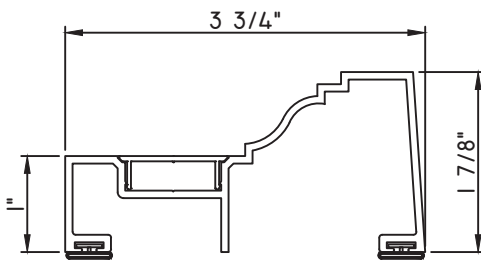

3 3/4" MULL COVER

M24837 - MULL COVER
M536207 - CAP
BPN-9159 - W.S. (QTY. 2)

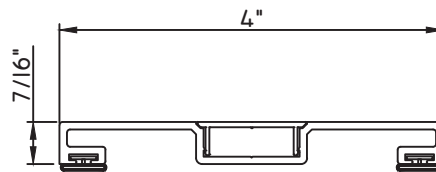

4" MULL COVER

M536208 - MULL COVER
M536207 - CAP
BPN-9159 - W.S. (QTY. 2)

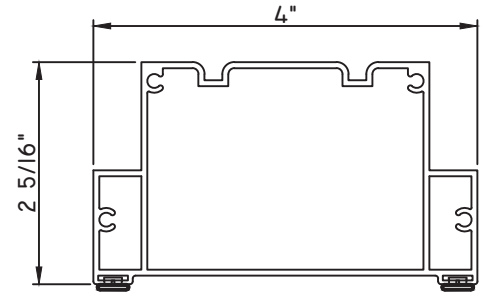

4" MULL COVER

M24428 - MULL COVER
BPN-9159 - W.S. (QTY. 2)
MH8-18X1 LP - SCREW (QTY. 8)

SCALE 1:2

Our products are tested to the standards of and certified by some of the foremost organizations in the fenestration industry.





H450 Series Casement, Project-Out, Fixed Mull Covers

All information seen within this document are considered current. However periodic changes/updates to our products are necessary. Quaker Window Products Inc. reserves the right to change any information without notice.

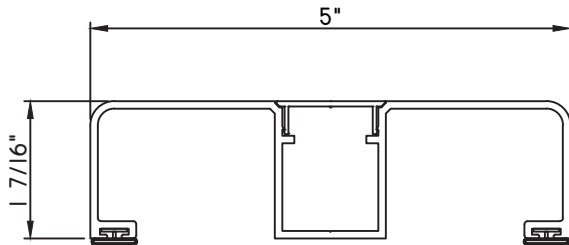

5" MULL COVER

M23978 - MULL COVER
M536207 - CAP
BPN-9159 - W.S. (QTY. 2)

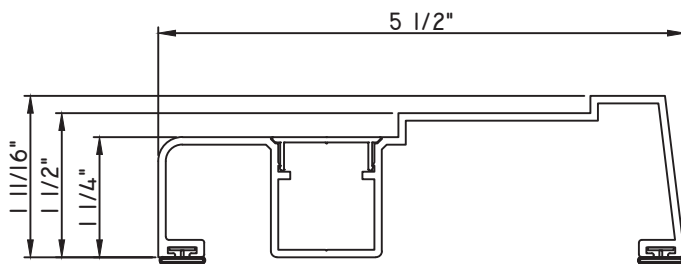

5 1/2" MULL COVER

M23979 - MULL COVER
M536207 - CAP
BPN-9159 - W.S. (QTY. 2)

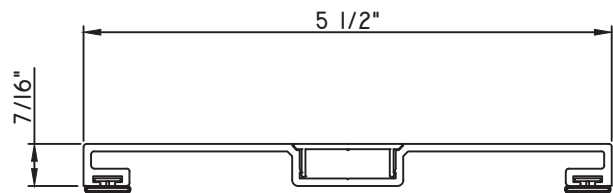

5 1/2" MULL COVER

M536206 - MULL COVER
M536207 - CAP
BPN-9159 - W.S. (QTY. 2)

SCALE 1:2

Our products are tested to the standards of and certified by some of the foremost organizations in the fenestration industry.





H450 Series Casement, Project-Out, Fixed Mull Covers

All information seen within this document are considered current. However periodic changes/updates to our products are necessary. Quaker Window Products Inc. reserves the right to change any information without notice.

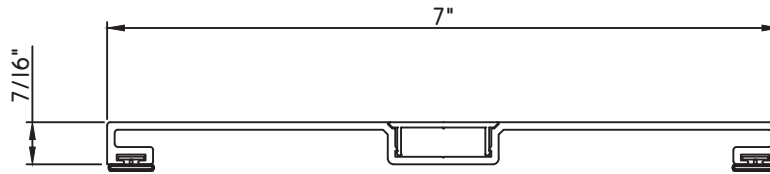

7" MULL COVER

M12794 - MULL COVER
M536207 - CAP
BPN-9159 - W.S. (QTY. 2)

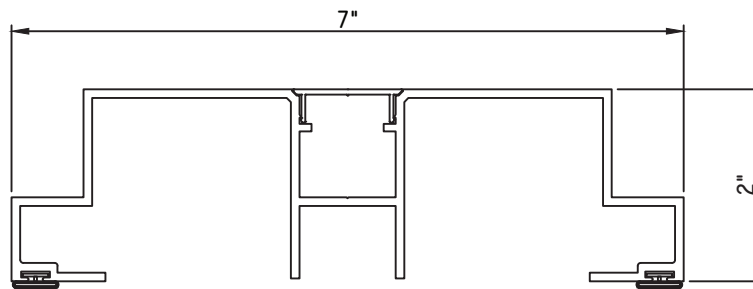

7" MULL COVER

M25907 - MULL COVER
M536207 - CAP
BPN-9159 - W.S. (QTY. 2)

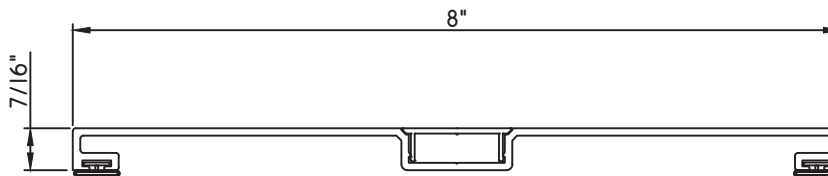

8" MULL COVER

M23410 - MULL COVER
M536207 - CAP
BPN-9159 - W.S. (QTY. 2)

SCALE 1:2

Our products are tested to the standards of and certified by some of the foremost organizations in the fenestration industry.

