

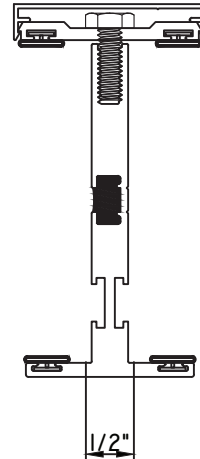

H650 Single Hung Mulls

All information seen within this document are considered current. However periodic changes/updates to our products are necessary. Quaker Window Products Inc. reserves the right to change any information without notice.

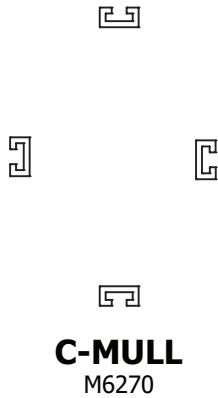

- T-MULL**
M24628 - T-MULL
MAX17386 - BASE
MAX14141 - CAP
BPN-9159 - W.S. (QTY. 4)
MH1/4 20X3/4 - BOLTS (18" APROX. O.C.)
M13404 - L-ANGLE (QTY. 2)
MF8-15X7/8-8HD - FASTENERS (QTY. 2)
MF8-15X1 1/2 - FASTENERS (QTY. 2)

**MUST BE USED WITH STANDARD
3 1/4" RECEPTOR & SUBSILLS**

SCALE 1:2

Our products are tested to the standards of and certified by some of the foremost organizations in the fenestration industry.



All information seen within this document are considered current. However periodic changes/updates to our products are necessary. Quaker Window Products Inc. reserves the right to change any information without notice.

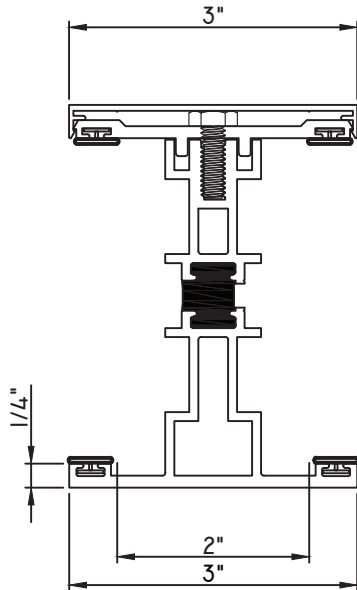

HEAVY WALL T-MULL

- M21045 - T-MULL
- M21043 - BASE
- M21044 - CAP
- BPN-9159 - W.S. (QTY. 4)
- MT1/4 20X5/8 - BOLTS (18" APROX. O.C.)
- M13404 - L-ANGLE (QTY. 2)
- MF8-15X7/8-8HD - FASTENERS (QTY. 2)
- MF8-15X1 1/2 - FASTENERS (QTY. 2)

**MUST BE USED WITH HEAVY WALL
3 1/4" RECEPTOR & SUBSILLS**

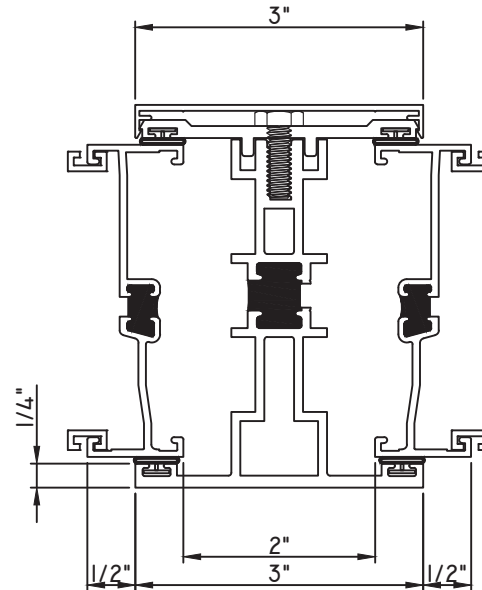

HEAVY WALL T-MULL/1" STACK MULL LEFT/RIGHT

- M21045 - T-MULL
- M21043 - BASE
- M21044 - CAP
- M21087 - 1" STACK MULL LEFT/RIGHT

SCALE 1:2

Our products are tested to the standards of and certified by some of the foremost organizations in the fenestration industry.





H650 Single Hung Mulls

All information seen within this document are considered current. However periodic changes/updates to our products are necessary. Quaker Window Products Inc. reserves the right to change any information without notice.



BULLNOSE T-MULL W/ 1 1/4" INTERIOR CAP

- M21086 - T-MULL
- M14895 - BASE
- M14896 - CAP
- BPN-9159 - W.S. (QTY. 4)
- MH1/4 20X3/4 - BOLTS (18" APROX. O.C.)
- M13404 - L-ANGLE (QTY. 2)
- MF8-15X7/8-8HD - FASTENERS (QTY. 2)
- MF8-15X1 1/2 - FASTENERS (QTY. 2)

CAN'T BE USED WITH RECEPTOR & SUBSILL INSTALLATION

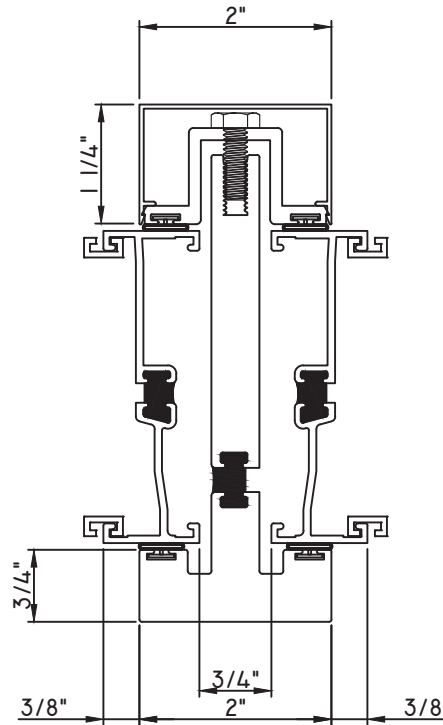

BULLNOSE T-MULL W/ 1 1/4" INTERIOR CAP / 1" STACK MULL LEFT/RIGHT

- M21086 - T-MULL
 - M14895 - BASE
 - M14896 - CAP
 - M21087 - 1" STACK MULL LEFT/RIGHT
- CAN'T BE USED WITH RECEPTOR & SUBSILL INSTALLATION**

SCALE 1:2

Our products are tested to the standards of and certified by some of the foremost organizations in the fenestration industry.





H650 Single Hung Mulls

All information seen within this document are considered current. However periodic changes/updates to our products are necessary. Quaker Window Products Inc. reserves the right to change any information without notice.

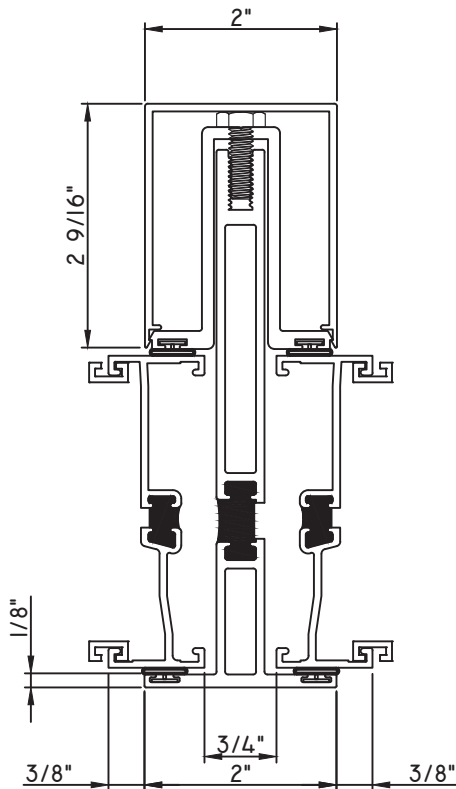

T-MULL W/ 2 9/16" INTERIOR CAP/ 1" STACK MULL LEFT

- M21856 - T-MULL
- M21855 - BASE
- M21854 - CAP
- M21087 - 1" STACK MULL LEFT
- MUST BE USED WITH STANDARD
3 1/4" RECEPTOR & SUBSILLS**

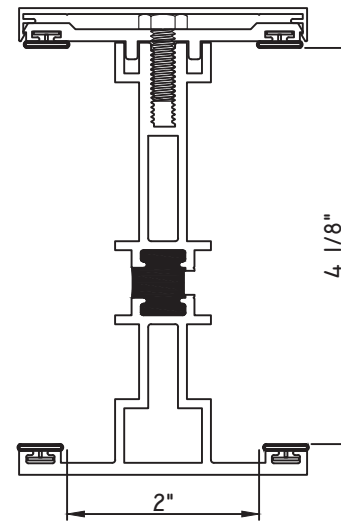

HEAVY WALL T-MULL

- M24895 - T-MULL
- M21043 - BASE
- M21044 - CAP
- BPN-9159 - W.S. (QTY. 4)
- MH1/4 20X3/4 - BOLTS (18" APROX. O.C.)
- M13404 - L-ANGLE (QTY. 2)
- MF8-15X7/8-8HD - FASTENERS (QTY. 2)
- MF8-15X1 1/2 - FASTENERS (QTY. 2)

M24895 I VALUE = 4.0072

SCALE 1:2

Our products are tested to the standards of and certified by some of the foremost organizations in the fenestration industry.





H650 Single Hung Mulls

All information seen within this document are considered current. However periodic changes/updates to our products are necessary. Quaker Window Products Inc. reserves the right to change any information without notice.

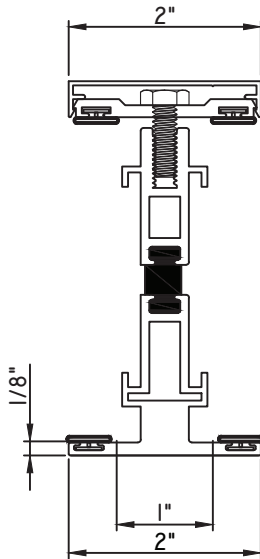

T-MULL

M22126 - T-MULL
MAX17386 - BASE
MAX14141 - CAP

BPN-9159 - W.S. (QTY. 4)
MH1/4 20X3/4 - BOLTS (18" APROX. O.C.)

PARTS FOR NON NAIL FIN INSTALL:

M13404 - L-ANGLE (QTY. 2)
MF8-15X7/8-8HD - FASTENERS (QTY. 2)
MF8-15X1 1/2 - FASTENERS (QTY. 2)

PARTS FOR NAIL FIN INSTALL:

M22127 - Z-CLIP (QTY. 2)
M23616 - H450 Z-CLIP (QTY. 2)

**MUST BE USED WITH STANDARD
3 1/4" RECEPTOR & SUBSILLS**

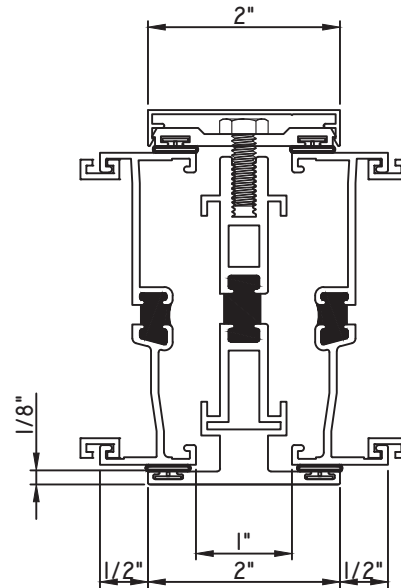

T-MULL/1" STACK MULL LEFT/RIGHT

M22126 - T-MULL
MAX17386 - BASE
MAX14141 - CAP
M21087 - 1" STACK MULL LEFT/RIGHT

**MUST BE USED WITH STANDARD
3 1/4" RECEPTOR & SUBSILLS**

SCALE 1:2

Our products are tested to the standards of and certified by some of the foremost organizations in the fenestration industry.





H650 Single Hung Mulls

All information seen within this document are considered current. However periodic changes/updates to our products are necessary. Quaker Window Products Inc. reserves the right to change any information without notice.

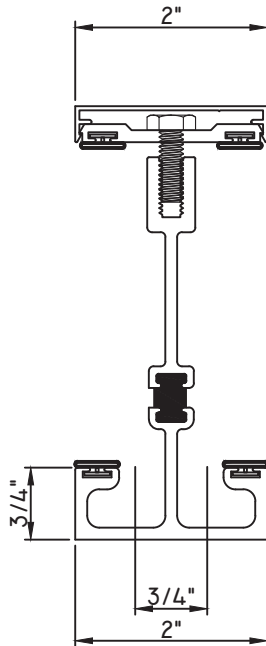

T-MULL

- M536203 - T-MULL
- M17386 - BASE
- MAX14141 - CAP
- BPN-9159 - W.S. (QTY. 4)
- MH1/4 20X3/4 - BOLTS (18" APROX. O.C.)
- M13404 - L-ANGLE (QTY. 2)
- MF8-15X7/8-8HD - FASTENERS (QTY. 2)
- MF8-15X1 1/2 - FASTENERS (QTY. 2)

**MUST BE USED WITH STANDARD
2 3/8" RECEPTOR & SUBSILL**

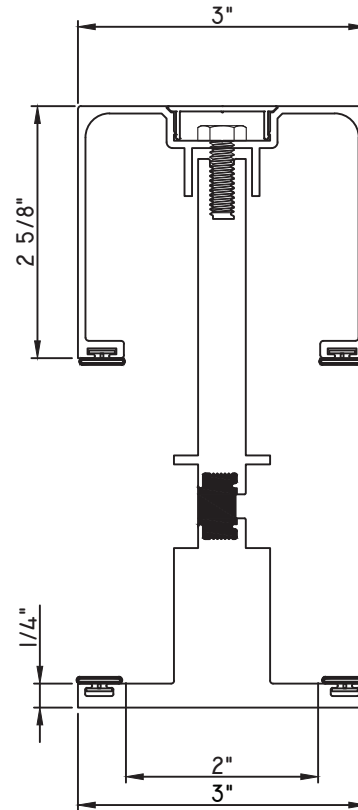

T-MULL

- M23980 - T-MULL
- M23981 - BASE
- M536207 - CAP
- BPN-9159 - W.S. (QTY. 4)
- MH1/4 20X3/4 - BOLTS (18" APROX. O.C.)
- M13404 - L-ANGLE (QTY. 2)
- MF8-15X7/8-8HD - FASTENERS (QTY. 2)
- MF8-15X1 1/2 - FASTENERS (QTY. 2)

SCALE 1:2

Our products are tested to the standards of and certified by some of the foremost organizations in the fenestration industry.





H650 Single Hung Mulls

All information seen within this document are considered current. However periodic changes/updates to our products are necessary. Quaker Window Products Inc. reserves the right to change any information without notice.

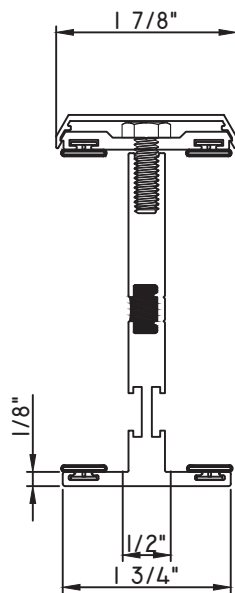

T-MULL

- M24628 - T-MULL
- M23056 - BASE
- M23058 - CAP
- BPN-9159 - W.S. (QTY. 4)
- MH1/4 20X3/4 - BOLTS (18" APROX. O.C.)
- PARTS FOR NON NAIL FIN INSTALL:
- M13404 - L-ANGLE (QTY. 2)
- MF8-15X7/8-8HD - FASTENERS (QTY. 2)
- MF8-15X1 1/2 - FASTENERS (QTY. 2)
- PARTS FOR NAIL FIN INSTALL:
- M22127 - Z-CLIP (QTY. 2)
- M23616 - H450 Z-CLIP (QTY. 2)

**MUST BE USED WITH STANDARD
3 1/4" RECEPTOR & SUBSILLS**

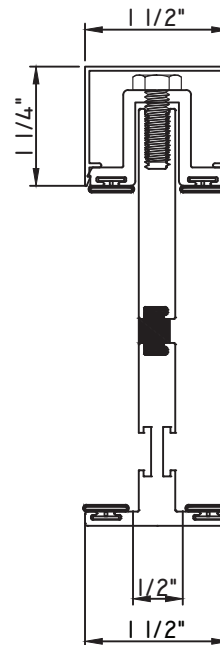

T-MULL

- M24500 - T-MULL (New Die)
- M234498 - BASE (New Die)
- M24499 - CAP (New Die)
- BPN-9159 - W.S. (QTY. 4)
- MH1/4 20X3/4 - BOLTS (18" APROX. O.C.)
- 5229-pc - ANCHOR (QTY. 2) (New Die)
- MPS-8X1 1/2 - FASTENERS (QTY. 2)

CAN ONLY BE USED WITH M600

SCALE 1:2

Our products are tested to the standards of and certified by some of the foremost organizations in the fenestration industry.





H650 Single Hung Mulls

All information seen within this document are considered current. However periodic changes/updates to our products are necessary. Quaker Window Products Inc. reserves the right to change any information without notice.

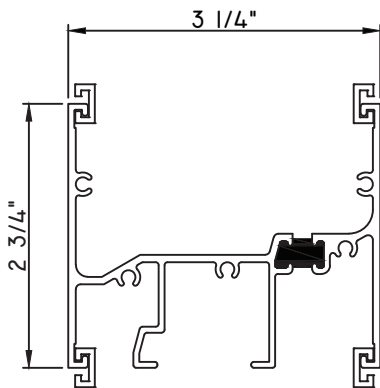

2 3/4" STACK MULL

- M15731 - STACK MULL
- M6270 - C-MULL (QTY. 2 OR 4)
- END DAM (QTY. 2)
- MH8-18X1 LP - SCREW (QTY. 8)
- 1226-(COLOR REQUIRED) - WEEP COVER

FACTORY APPLIED INSTALL ONLY

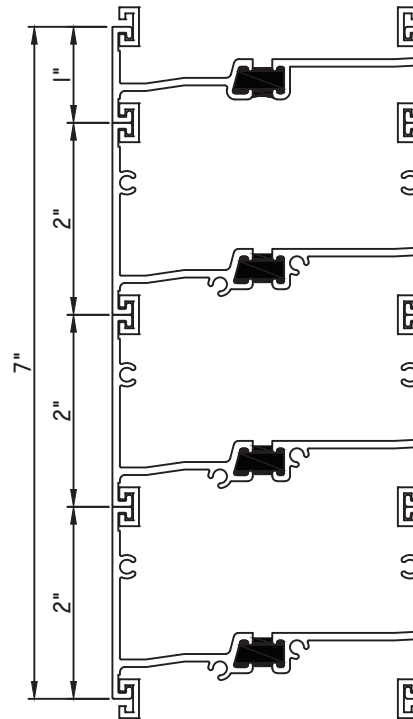

7" STACK MULL

- M16318 x3 - STACK MULL
- M6270 - C-MULL (QTY. 2 OR 4)
- 72406 - END DAM (QTY. 2)
- MH8-18X1 LP - SCREW (QTY. 8)
- 1226-(COLOR REQUIRED) - WEEP COVER

FACTORY APPLIED INSTALL ONLY

SCALE 1:2

Our products are tested to the standards of and certified by some of the foremost organizations in the fenestration industry.





H650 Single Hung Mulls

All information seen within this document are considered current. However periodic changes/updates to our products are necessary. Quaker Window Products Inc. reserves the right to change any information without notice.

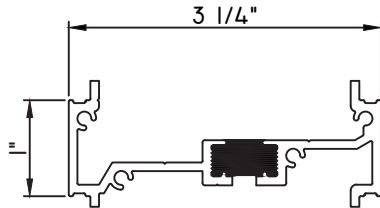

1" STACK MULL

- M23723 - STACK MULL
- 1226-(COLOR REQUIRED) - WEEP COVER
- QWP-M23723 - END DAM (QTY. 2)
- M23845-PCS - M600 NAIL FIN END DAM
- M23846-PCS - H450 NAIL FIN END DAM
- MH8-18X1 LP - SCREW (QTY. 8)

FIELD APPLIED INSTALL ONLY

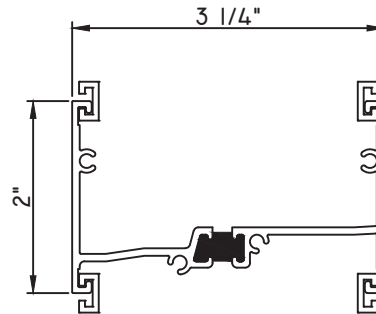

2" STACK MULL

- M16318 - STACK MULL
- M6270 - C-MULL (QTY. 2 OR 4)
- 72406 - END DAM (QTY. 2)
- MH8-18X1 LP - SCREW (QTY. 8)
- 1226-(COLOR REQUIRED) - WEEP COVER

FACTORY APPLIED INSTALL ONLY

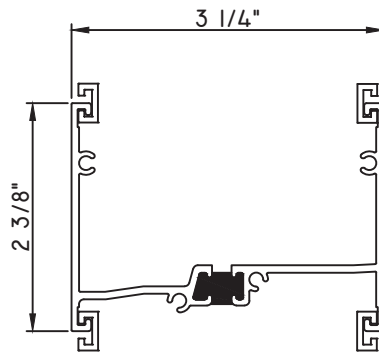

2 3/8" STACK MULL

- M22015 - STACK MULL
- M6270 - C-MULL (QTY. 2 OR 4)
- QWP-032917 - END DAM (QTY. 2)
- MH8-18X1 LP - SCREW (QTY. 8)
- 1226-(COLOR REQUIRED) - WEEP COVER

FACTORY APPLIED INSTALL ONLY

SCALE 1:2

Our products are tested to the standards of and certified by some of the foremost organizations in the fenestration industry.





H650 Single Hung Mulls

All information seen within this document are considered current. However periodic changes/updates to our products are necessary. Quaker Window Products Inc. reserves the right to change any information without notice.

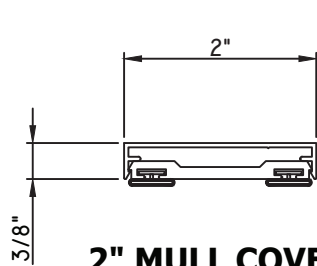

2" MULL COVER
MAX17386 - BASE
MAX14141 - CAP
BPN-9159 - W.S. (QTY. 2)

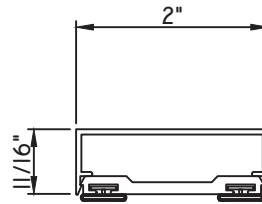

2" MULL COVER
MAX17386 - BASE
M23502 - CAP
BPN-9159 - W.S. (QTY. 2)

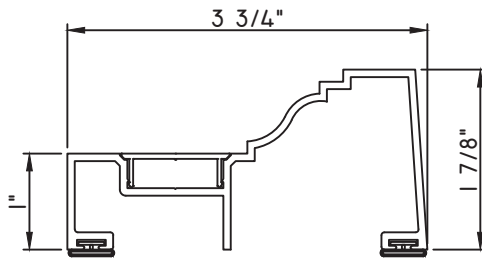

3 3/4" MULL COVER
M24837 - MULL COVER
M536207 - CAP
BPN-9159 - W.S. (QTY. 2)

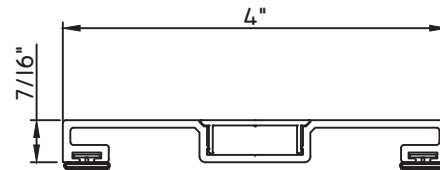

4" MULL COVER
M536208 - MULL COVER
M536207 - CAP
BPN-9159 - W.S. (QTY. 2)

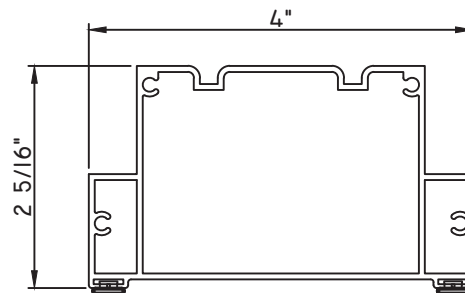

4" MULL COVER
M24428 - MULL COVER
BPN-9159 - W.S. (QTY. 2)
MH8-18X1 LP - SCREW (QTY. 8)

SCALE 1:2

Our products are tested to the standards of and certified by some of the foremost organizations in the fenestration industry.





H650 Single Hung Mulls

All information seen within this document are considered current. However periodic changes/updates to our products are necessary. Quaker Window Products Inc. reserves the right to change any information without notice.

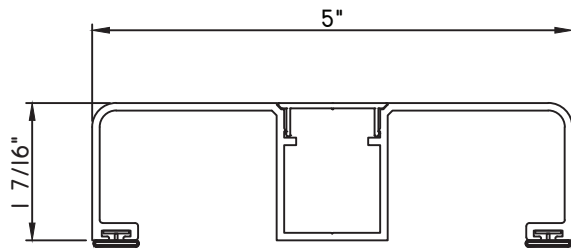

5 " MULL COVER
M23978 - MULL COVER
M536207 - CAP
BPN-9159 - W.S. (QTY. 2)

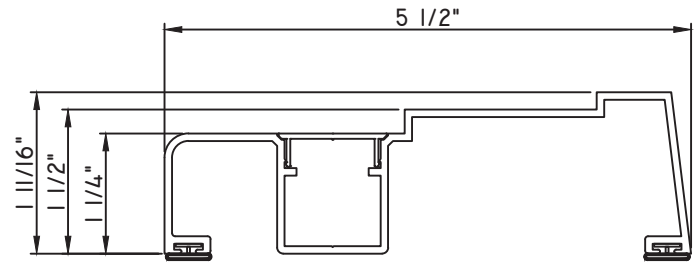

5 1/2" MULL COVER
M23979 - MULL COVER
M536207 - CAP
BPN-9159 - W.S. (QTY. 2)

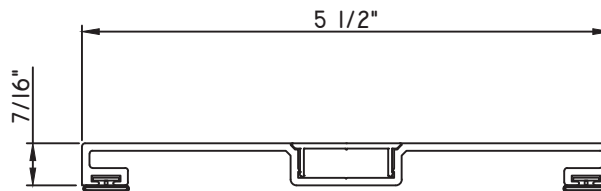

5 1/2" MULL COVER
M536206 - MULL COVER
M536207 - CAP
BPN-9159 - W.S. (QTY. 2)

SCALE 1:2

Our products are tested to the standards of and certified by some of the foremost organizations in the fenestration industry.





H650 Single Hung Mulls

All information seen within this document are considered current. However periodic changes/updates to our products are necessary. Quaker Window Products Inc. reserves the right to change any information without notice.

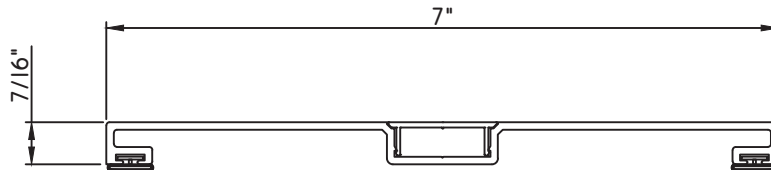

7" MULL COVER
M12794 - MULL COVER
M536207 - CAP
BPN-9159 - W.S. (QTY. 2)

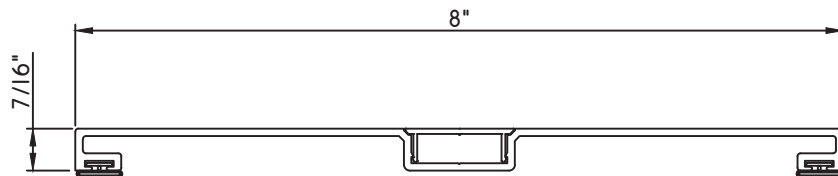

8" MULL COVER
M23410 - MULL COVER
M536207 - CAP
BPN-9159 - W.S. (QTY. 2)

SCALE 1:2

Our products are tested to the standards of and certified by some of the foremost organizations in the fenestration industry.

