

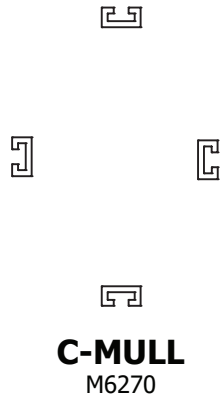

K200 Series Hung, Horizontal Slider, Fixed Mulls

All information seen within this document are considered current. However periodic changes/updates to our products are necessary. Quaker Window Products Inc. reserves the right to change any information without notice.



C-MULL
M6270

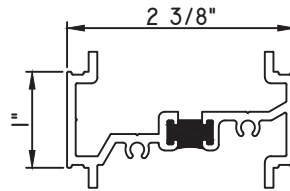

1" STACK MULL
MW25615 - STACK MULL
970-300 - WEEP COVER
MH8-18X1 LP - SCREW (QTY. 4)

FIELD APPLIED INSTALL ONLY

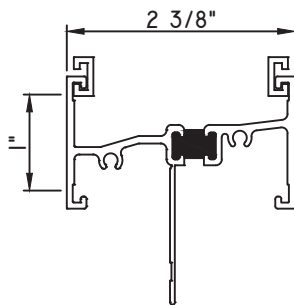

1 3/8" STACK MULL
MW23712 - STACK MULL
QWP-070706 - END DAMS (QTY. 2)
MH8-18X1 LP - SCREW (QTY. 4)
970-300 - WEEP COVER

FACTORY APPLIED INSTALL ONLY

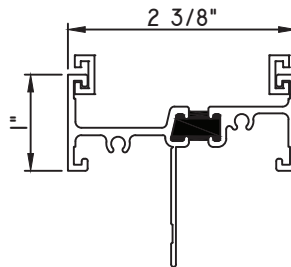

1" STACK MULL
M43325 - STACK MULL
QWP-43325 - END DAMS (QTY. 2)
MH8-18X1 LP - SCREW (QTY. 4)
970-300 - WEEP COVER

SCALE 1:2

Our products are tested to the standards of and certified by some of the foremost organizations in the fenestration industry.





K200 Series Hung, Horizontal Slider, Fixed Mulls

All information seen within this document are considered current. However periodic changes/updates to our products are necessary. Quaker Window Products Inc. reserves the right to change any information without notice.

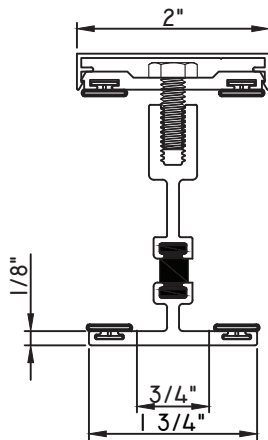

T-MULL

- M16690 - T-MULL
- MAX17386 - BASE
- MAX14141 - CAP
- BPN-9159 - W.S. (QTY. 4)
- MH1/4 20X3/4 - BOLTS (18" APROX. O.C.)
- M13404 - L-ANGLE (QTY. 2)
- MF8-15X7/8-8HD - FASTENERS (QTY. 2)
- MF8-15X1 1/2 - FASTENERS (QTY. 2)

**MUST BE USED WITH STANDARD
2 3/8" RECEPTOR & SUBSILL**

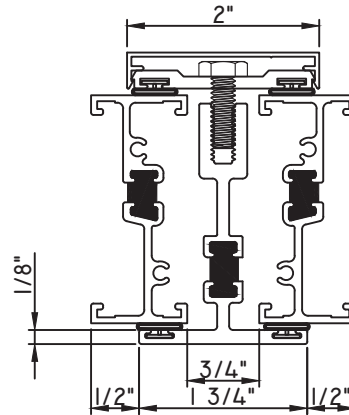

T-MULL/1" STACK LEFT/RIGHT

- M16690 - T-MULL
- MAX17386 - BASE
- MAX14141 - CAP
- 1" STACK MULL - M43325 LEFT/RIGHT
- BPN-9159 - W.S. (QTY. 4)
- MH1/4 20X3/4 - BOLTS (18" APROX. O.C.)
- M13404 - L-ANGLE (QTY. 2)
- MF8-15X7/8-8HD - FASTENERS (QTY. 2)
- MF8-15X1 1/2 - FASTENERS (QTY. 2)

**MUST BE USED WITH STANDARD
2 3/8" RECEPTOR & SUBSILL**

SCALE 1:2

Our products are tested to the standards of and certified by some of the foremost organizations in the fenestration industry.





K200 Series Hung, Horizontal Slider, Fixed Mulls

All information seen within this document are considered current. However periodic changes/updates to our products are necessary. Quaker Window Products Inc. reserves the right to change any information without notice.

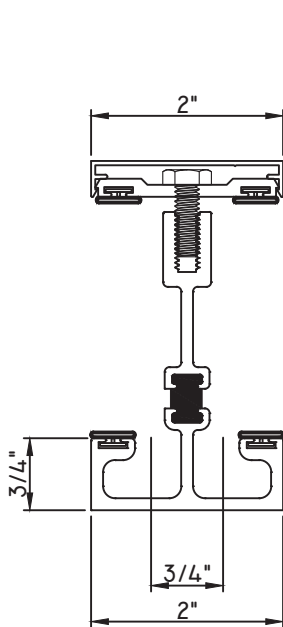

T-MULL

- M14536 - T-MULL
- MAX17386 - BASE
- MAX14141 - CAP
- BPN-9159 - W.S. (QTY. 4)
- MH1/4 20X3/4 - BOLTS (18" APPROX. O.C.)
- M13404 - L-ANGLE (QTY. 2)
- MF8-15X7/8-8HD - FASTENERS (QTY. 2)
- MF8-15X1 1/2 - FASTENERS (QTY. 2)

**MUST BE USED WITH STANDARD
2 3/8" RECEPTOR & SUBSILL**

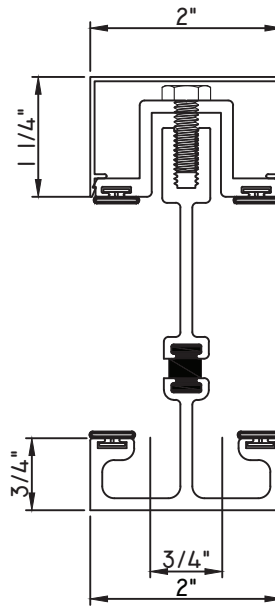

T-MULL

- M536203 - T-MULL
- M14895 - BASE
- M14896 - CAP
- BPN-9159 - W.S. (QTY. 4)
- MH1/4 20X3/4 - BOLTS (18" APPROX. O.C.)
- M13404 - L-ANGLE (QTY. 2)
- MF8-15X7/8-8HD - FASTENERS (QTY. 2)
- MF8-15X1 1/2 - FASTENERS (QTY. 2)

**MUST BE USED WITH STANDARD
2 3/8" RECEPTOR & SUBSILL**

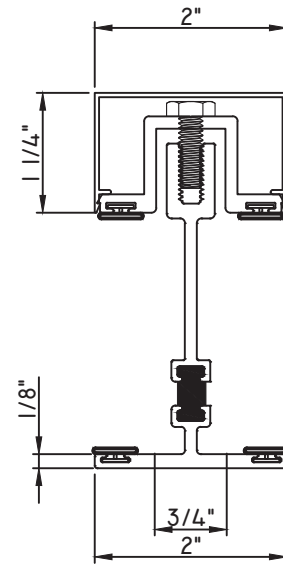

T-MULL

- M16875 - T-MULL
- M14895 - BASE
- M14896 - CAP

Our products are tested to the standards of and certified by some of the foremost organizations in the fenestration industry.



SCALE 1:2



K200 Series Hung, Horizontal Slider, Fixed Mulls

All information seen within this document are considered current. However periodic changes/updates to our products are necessary. Quaker Window Products Inc. reserves the right to change any information without notice.

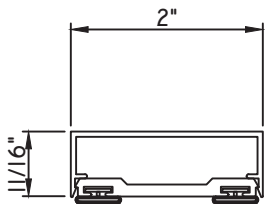

2" MULL COVER
MAX17386 - BASE
M23502 - CAP
BPN-9159 - W.S. (QTY. 2)

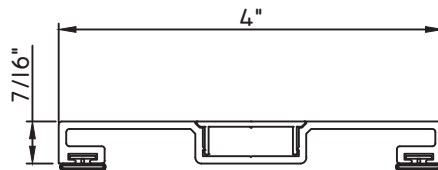

4" MULL COVER
M536208 - MULL COVER
M536207 - CAP
BPN-9159 - W.S. (QTY. 2)

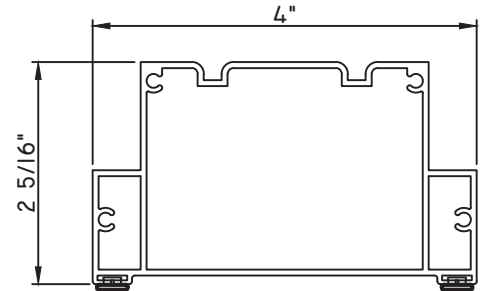

4" MULL COVER
M24428 - MULL COVER
BPN-9159 - W.S. (QTY. 2)
MH8-18X1 LP - SCREW (QTY. 8)

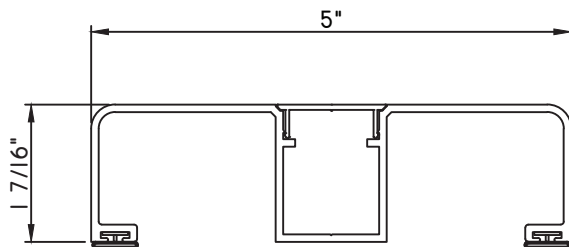

5" MULL COVER
M23978 - MULL COVER
M536207 - CAP
BPN-9159 - W.S. (QTY. 2)

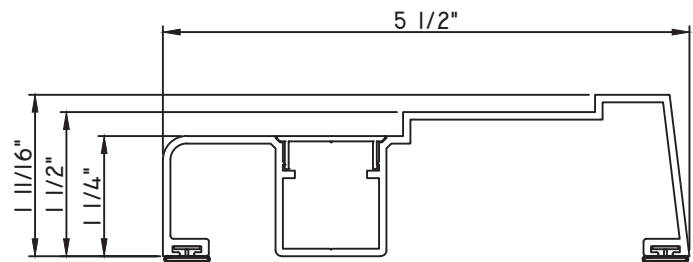

5 1/2" MULL COVER
M23979 - MULL COVER
M536207 - CAP
BPN-9159 - W.S. (QTY. 2)

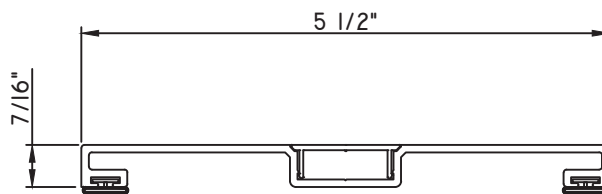

5 1/2" MULL COVER
M536206 - MULL COVER
M536207 - CAP
BPN-9159 - W.S. (QTY. 2)

SCALE 1:2

Our products are tested to the standards of and certified by some of the foremost organizations in the fenestration industry.





K200 Series Hung, Horizontal Slider, Fixed Mulls

All information seen within this document are considered current. However periodic changes/updates to our products are necessary. Quaker Window Products Inc. reserves the right to change any information without notice.

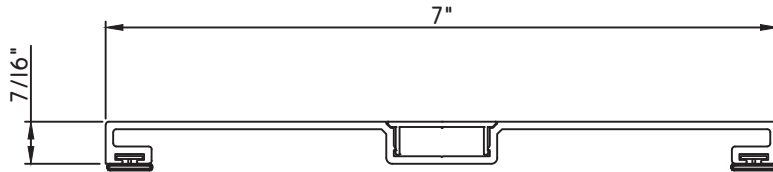

7" MULL COVER
M12794 - MULL COVER
M536207 - CAP
BPN-9159 - W.S. (QTY. 2)

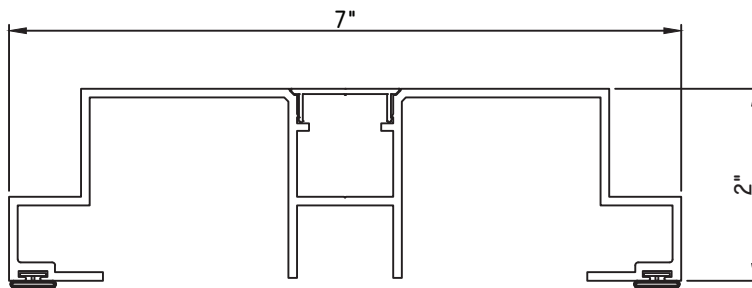

7" MULL COVER
M25907 - MULL COVER
M536207 - CAP
BPN-9159 - W.S. (QTY. 2)

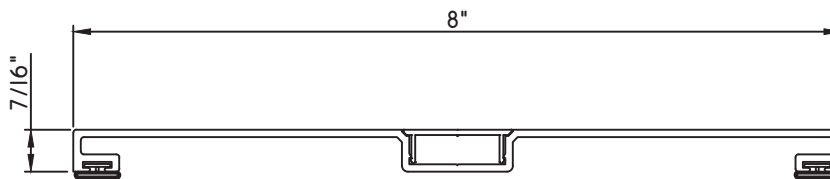

8" MULL COVER
M23410 - MULL COVER
M536207 - CAP
BPN-9159 - W.S. (QTY. 2)

SCALE 1:2

Our products are tested to the standards of and certified by some of the foremost organizations in the fenestration industry.

