

All information seen within this document are considered current. However periodic changes/updates to our products are necessary. Quaker Window Products Inc. reserves the right to change any information without notice.

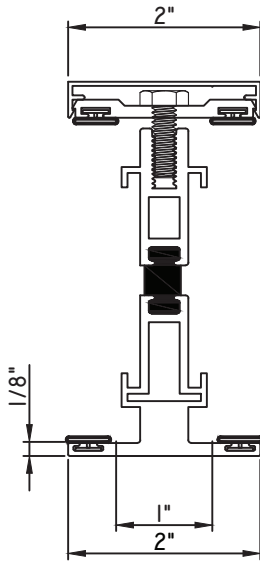

T-MULL

- M22126 - T-MULL
- MAX17386 - BASE
- MAX14141 - CAP
- BPN-9159 - W.S. (QTY. 4)
- MH1/4 20X3/4 - BOLTS (18" APPROX. O.C.)
- PARTS FOR NON NAIL FIN INSTALL:
- M13404 - L-ANGLE (QTY. 2)
- MF8-15X7/8-8HD - FASTENERS (QTY. 2)
- MF8-15X1 1/2 - FASTENERS (QTY. 2)
- PARTS FOR NAIL FIN INSTALL:
- M22127 - Z-CLIP (QTY. 2)
- M23616 - H450 Z-CLIP (QTY. 2)

**MUST BE USED WITH STANDARD
3 1/4" RECEPTOR & SUBSILLS**

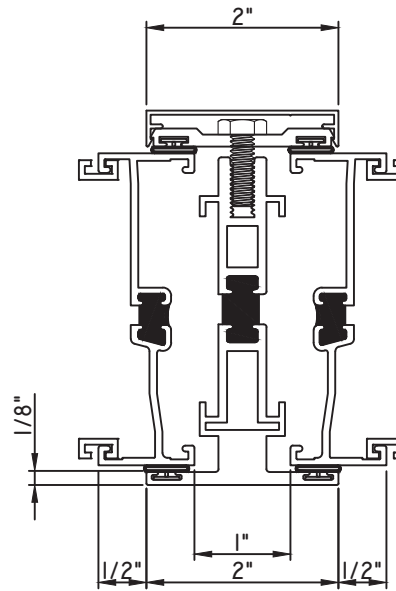

T-MULL/1" STACK MULL LEFT/RIGHT

- M22126 - T-MULL
- MAX17386 - BASE
- MAX14141 - CAP
- M21087 - 1" STACK MULL LEFT/RIGHT

**MUST BE USED WITH STANDARD
3 1/4" RECEPTOR & SUBSILLS**

SCALE 1:2

Our products are tested to the standards of and certified by some of the foremost organizations in the fenestration industry.



All information seen within this document are considered current. However periodic changes/updates to our products are necessary. Quaker Window Products Inc. reserves the right to change any information without notice.

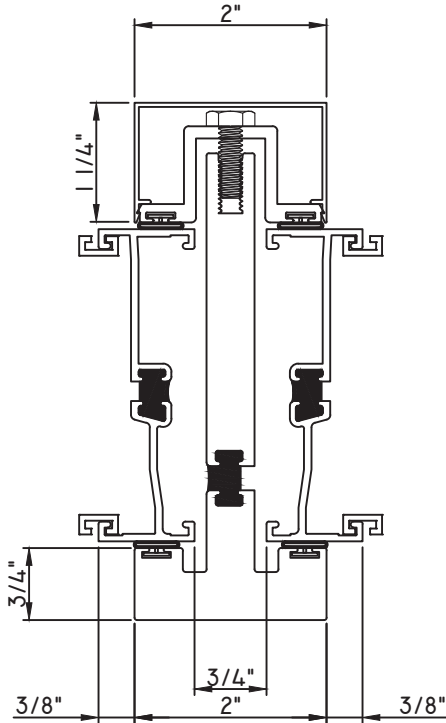

**BULLNOSE T-MULL W/
1 1/4" INTERIOR CAP / 1" STACK MULL LEFT/RIGHT**

M21086 - T-MULL
M14895 - BASE
M14896 - CAP
M21087 - 1" STACK MULL LEFT/RIGHT
**CAN'T BE USED WITH RECEPTOR &
SUBSILL INSTALLATION**

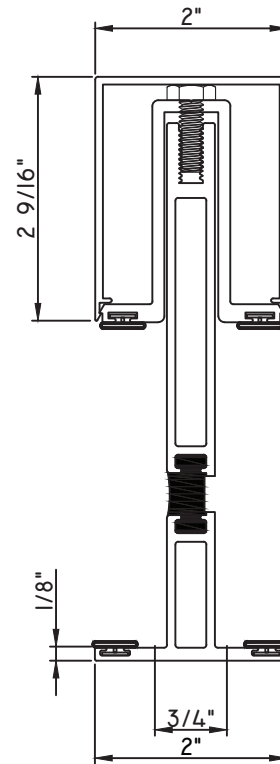

T-MULL W/ 2 9/16" INTERIOR CAP

M21856 - T-MULL
M21855 - BASE
M21854 - CAP
BPN-9159 - W.S. (QTY. 4)
MH1/4 20X3/4 - BOLTS (18" APROX. O.C.)
M13404 - L-ANGLE (QTY. 2)
MF8-15X7/8-8HD - FASTENERS (QTY. 2)
MF8-15X1 1/2 - FASTENERS (QTY. 2)

**MUST BE USED WITH STANDARD
3 1/4" RECEPTOR & SUBSILLS**

SCALE 1:2

Our products are tested to the standards of and certified by some of the foremost organizations in the fenestration industry.



All information seen within this document are considered current. However periodic changes/updates to our products are necessary. Quaker Window Products Inc. reserves the right to change any information without notice.

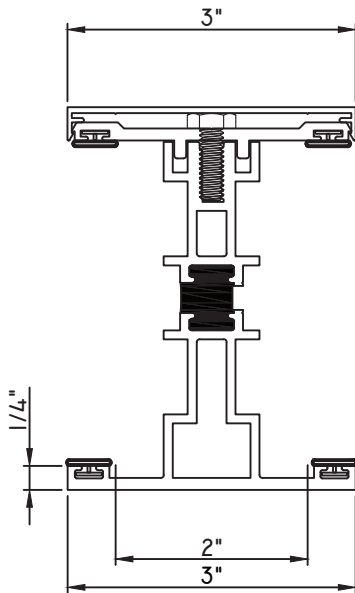

HEAVY WALL T-MULL

M21045 - T-MULL

M21043 - BASE

M21044 - CAP

BPN-9159 - W.S. (QTY. 4)

MT1/4 20X5/8 - BOLTS (18" APROX. O.C.)

M13404 - L-ANGLE (QTY. 2)

MF8-15X7/8-8HD - FASTENERS (QTY. 2)

MF8-15X1 1/2 - FASTENERS (QTY. 2)

**MUST BE USED WITH HEAVY WALL
3 1/4" RECEPTOR & SUBSILLS**

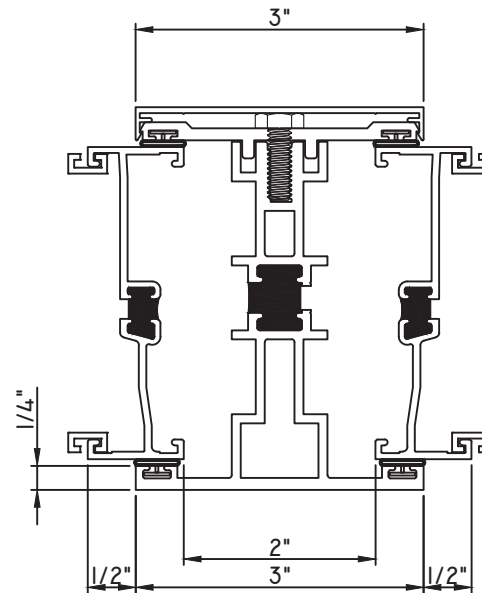

HEAVY WALL T-MULL/1" STACK MULL LEFT/RIGHT

M21045 - T-MULL

M21043 - BASE

M21044 - CAP

M21087 - 1" STACK MULL LEFT/RIGHT

SCALE 1:2

Our products are tested to the standards of and certified by some of the foremost organizations in the fenestration industry.



All information seen within this document are considered current. However periodic changes/updates to our products are necessary. Quaker Window Products Inc. reserves the right to change any information without notice.

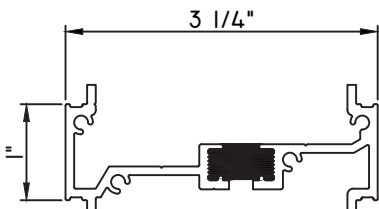

1" STACK MULL

M23723 - STACK MULL
1226-(COLOR REQUIRED) - WEEP COVER
QWP-M23723 - END DAM (QTY. 2)
M23845-PCS - M600 NAIL FIN END DAM
M23846-PCS - H450 NAIL FIN END DAM
MH8-18X1 LP - SCREW (QTY. 8)

FIELD APPLIED INSTALL ONLY

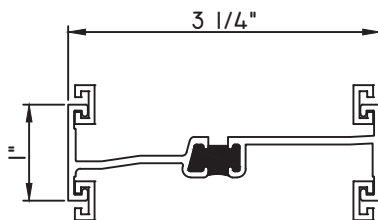

1" STACK MULL

M21087 - STACK MULL
M6270 - C-MULL (QTY. 2 OR 4)
1226-(COLOR REQUIRED) - WEEP COVE

FACTORY APPLIED INSTALL ONLY

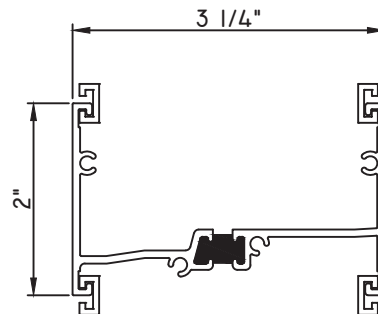

2" STACK MULL

M16318 - STACK MULL
M6270 - C-MULL (QTY. 2 OR 4)
72406 - END DAM (QTY. 2)
MH8-18X1 LP - SCREW (QTY. 8)
1226-(COLOR REQUIRED) - WEEP COVER

FACTORY APPLIED INSTALL ONLY

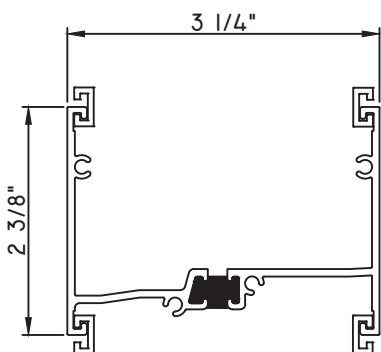

2 3/8" STACK MULL

M22015 - STACK MULL
M6270 - C-MULL (QTY. 2 OR 4)
QWP-032917 - END DAM (QTY. 2)
MH8-18X1 LP - SCREW (QTY. 8)
1226-(COLOR REQUIRED) - WEEP COVER

FACTORY APPLIED INSTALL ONLY

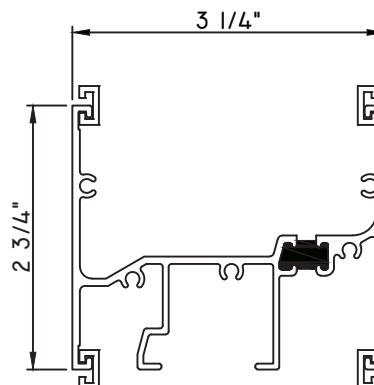

2 3/4" STACK MULL

M15731 - STACK MULL
M6270 - C-MULL (QTY. 2 OR 4)
- END DAM (QTY. 2)
MH8-18X1 LP - SCREW (QTY. 8)
1226-(COLOR REQUIRED) - WEEP COVER

FACTORY APPLIED INSTALL ONLY

SCALE 1:2

Our products are tested to the standards of and certified by some of the foremost organizations in the fenestration industry.



All information seen within this document are considered current. However periodic changes/updates to our products are necessary. Quaker Window Products Inc. reserves the right to change any information without notice.

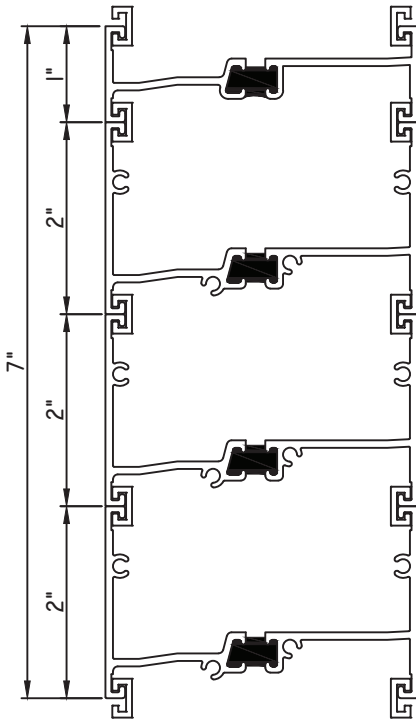

7" STACK MULL

M16318 x3 - STACK MULL
M6270 - C-MULL (QTY. 2 OR 4)
72406 - END DAM (QTY. 2)
MH8-18X1 LP - SCREW (QTY. 8)
1226-(COLOR REQUIRED) - WEEP COVER

FACTORY APPLIED INSTALL ONLY

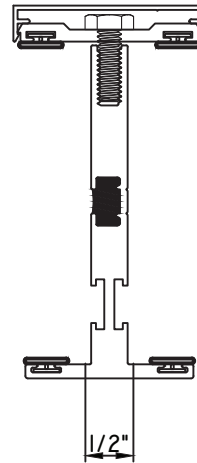

T-MULL

M24628 - T-MULL
MAX17386 - BASE
MAX14141 - CAP
BPN-9159 - W.S. (QTY. 4)
MH1/4 20X3/4 - BOLTS (18" APROX. O.C.)
M13404 - L-ANGLE (QTY. 2)
MF8-15X7/8-8HD - FASTENERS (QTY. 2)
MF8-15X1 1/2 - FASTENERS (QTY. 2)

**MUST BE USED WITH STANDARD
3 1/4" RECEPTOR & SUBSILLS**

SCALE 1:2

Our products are tested to the standards of and certified by some of the foremost organizations in the fenestration industry.



All information seen within this document are considered current. However periodic changes/updates to our products are necessary. Quaker Window Products Inc. reserves the right to change any information without notice.

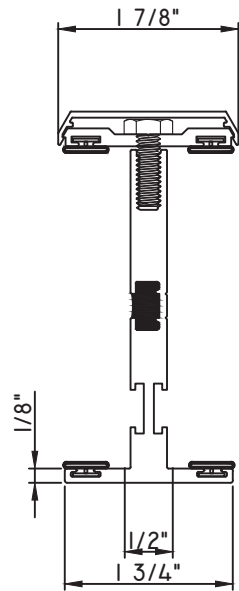

T-MULL

M24628 - T-MULL
M23056 - BASE
M23058 - CAP

BPN-9159 - W.S. (QTY. 4)

MH1/4 20X3/4 - BOLTS (18" APROX. O.C.)

PARTS FOR NON NAIL FIN INSTALL:

M13404 - L-ANGLE (QTY. 2)

MF8-15X7/8-8HD - FASTENERS (QTY. 2)

MF8-15X1 1/2 - FASTENERS (QTY. 2)

PARTS FOR NAIL FIN INSTALL:

M22127 - Z-CLIP (QTY. 2)

M23616 - H450 Z-CLIP (QTY. 2)

**MUST BE USED WITH STANDARD
3 1/4" RECEPTOR & SUBSILLS**

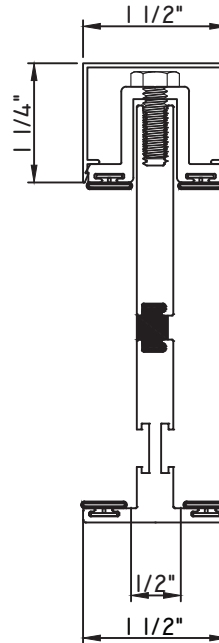

T-MULL

M24500 - T-MULL (New Die)

M234498 - BASE (New Die)

M24499 - CAP (New Die)

BPN-9159 - W.S. (QTY. 4)

MH1/4 20X3/4 - BOLTS (18" APROX. O.C.)

5229-pc - ANCHOR (QTY. 2) (New Die)

MPS-8X1 1/2 - FASTENERS (QTY. 2)

CAN ONLY BE USED WITH M600

SCALE 1:2

All information seen within this document are considered current. However periodic changes/updates to our products are necessary. Quaker Window Products Inc. reserves the right to change any information without notice.

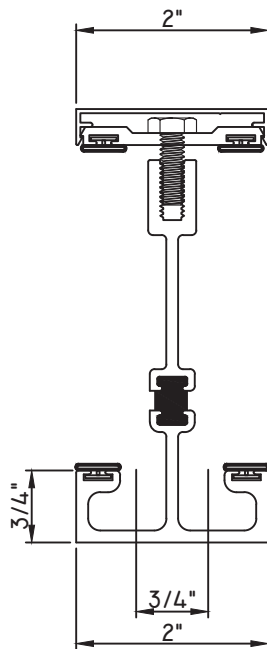

T-MULL

- M536203 - T-MULL
- M17386 - BASE
- MAX14141 - CAP
- BPN-9159 - W.S. (QTY. 4)
- MH1/4 20X3/4 - BOLTS (18" APPROX. O.C.)
- M13404 - L-ANGLE (QTY. 2)
- MF8-15X7/8-8HD - FASTENERS (QTY. 2)
- MF8-15X1 1/2 - FASTENERS (QTY. 2)

**MUST BE USED WITH STANDARD
2 3/8" RECEPTOR & SUBSILL**

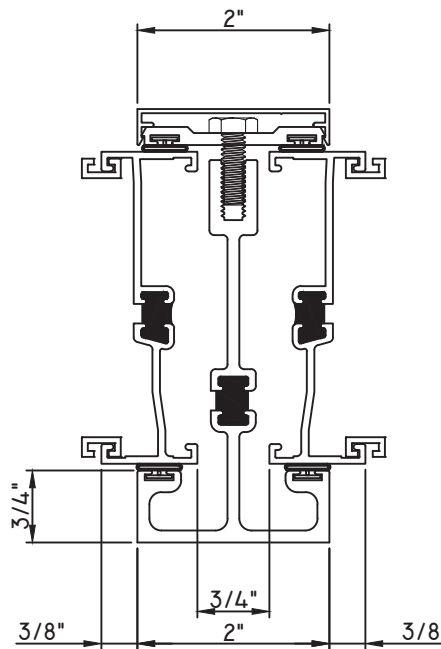

T-MULL/1" STACK MULL LEFT/RIGHT

- M536203 - T-MULL
 - M17386 - BASE
 - MAX14141 - CAP
 - M21087 - 1" STACK MULL LEFT/RIGHT
- MUST BE USED WITH STANDARD
2 3/8" RECEPTOR & SUBSILL**

SCALE 1:2

Our products are tested to the standards of and certified by some of the foremost organizations in the fenestration industry.



All information seen within this document are considered current. However periodic changes/updates to our products are necessary. Quaker Window Products Inc. reserves the right to change any information without notice.

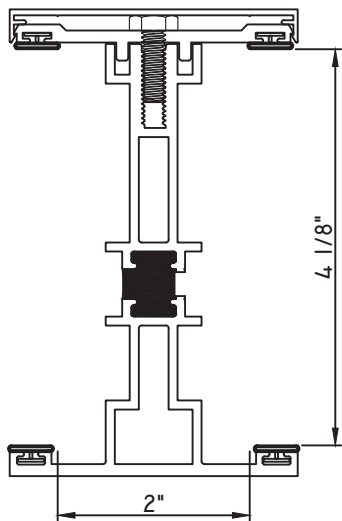

HEAVY WALL T-MULL

- M24895 - T-MULL
- M21043 - BASE
- M21044 - CAP
- BPN-9159 - W.S. (QTY. 4)
- MH1/4 20X3/4 - BOLTS (18" APROX. O.C.)
- M13404 - L-ANGLE (QTY. 2)
- MF8-15X7/8-8HD - FASTENERS (QTY. 2)
- MF8-15X1 1/2 - FASTENERS (QTY. 2)

M24895 I VALUE = 4.0072

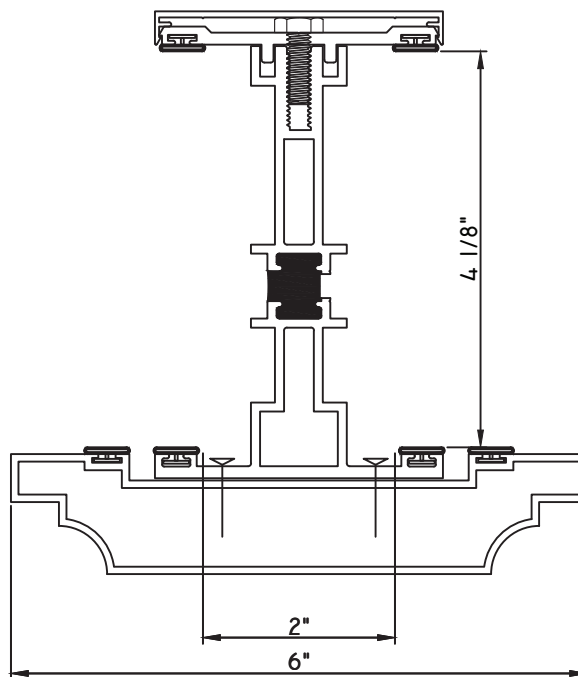

HEAVY WALL T-MULL

- M24895 - T-MULL
- M21043 - BASE
- M21044 - CAP
- BPN-9159 - W.S. (QTY. 4)
- MH1/4 20X3/4 - BOLTS (3" FROM EACH END & 16"O.C.)
- M13404 - L-ANGLE (QTY. 2)
- MF8-15X7/8-8HD - FASTENERS (QTY. 2)
- MF8-15X1 1/2 - FASTENERS (QTY. 2)
- OUTSIDE COVER - M24894 (FIELD APPLIED)
- MH8-18X3/4 TK2 - FASTENERS (3" FROM EACH END & 16"O.C.) x2

M24895 I VALUE = 4.0072

SCALE 1:2

Our products are tested to the standards of and certified by some of the foremost organizations in the fenestration industry.



All information seen within this document are considered current. However periodic changes/updates to our products are necessary. Quaker Window Products Inc. reserves the right to change any information without notice.

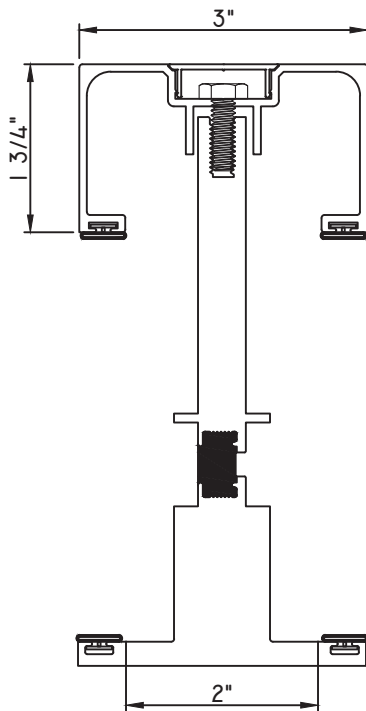

T-MULL

- M23980 - T-MULL
- M26058 - BASE (New Die)
- M536207 - CAP
- M13404 - L-ANGLE (QTY. 2)
- BPN-9159 - W.S. (QTY. 4)
- MH1/4 20X3/4 - BOLTS (18" APROX. O.C.)
- M13404 - L-ANGLE (QTY. 2)
- MF8-15X7/8-8HD - FASTENERS (QTY. 2)
- MF8-15X1 1/2 - FASTENERS (QTY. 2)

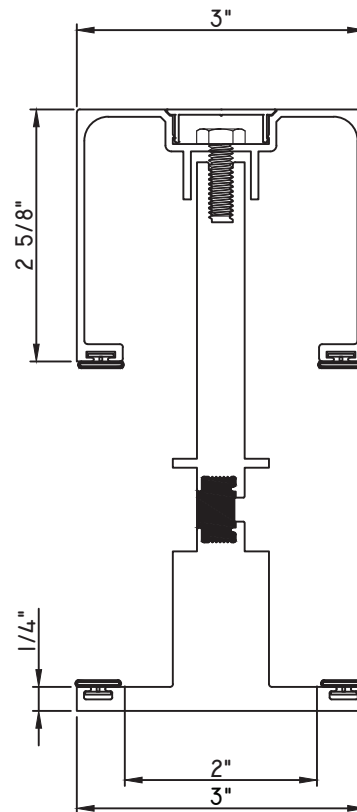

T-MULL

- M23980 - T-MULL
- M23981 - BASE
- M536207 - CAP
- BPN-9159 - W.S. (QTY. 4)
- MH1/4 20X3/4 - BOLTS (18" APROX. O.C.)
- M13404 - L-ANGLE (QTY. 2)
- MF8-15X7/8-8HD - FASTENERS (QTY. 2)
- MF8-15X1 1/2 - FASTENERS (QTY. 2)

SCALE 1:2

Our products are tested to the standards of and certified by some of the foremost organizations in the fenestration industry.



All information seen within this document are considered current. However periodic changes/updates to our products are necessary. Quaker Window Products Inc. reserves the right to change any information without notice.

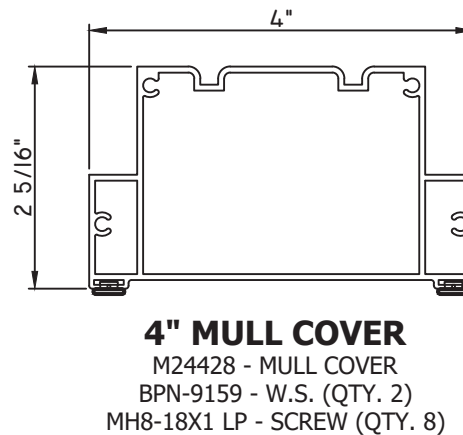
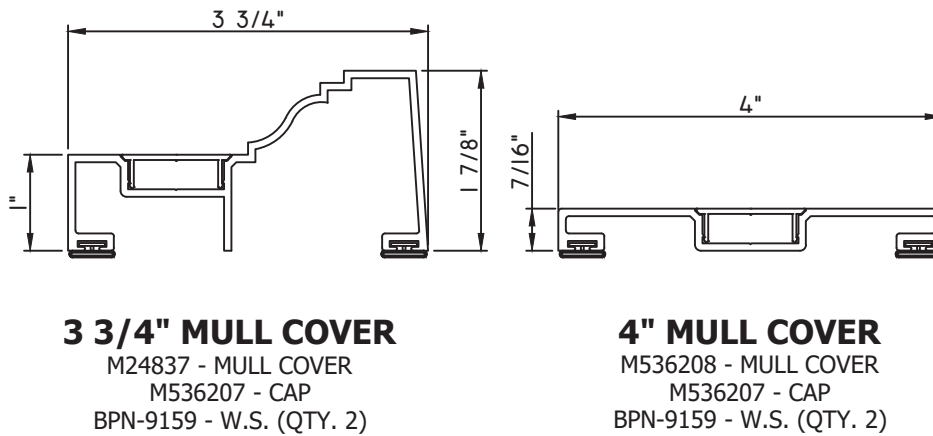
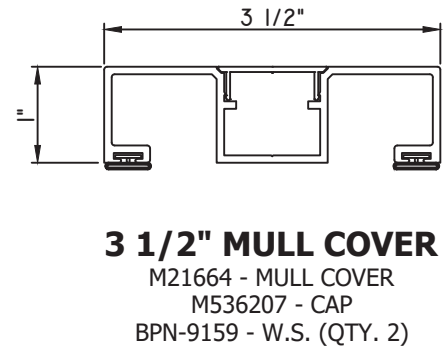
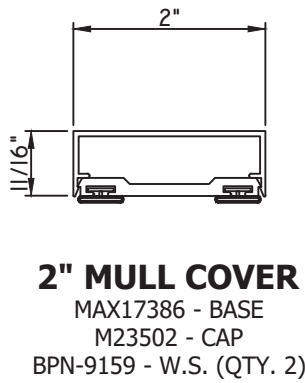
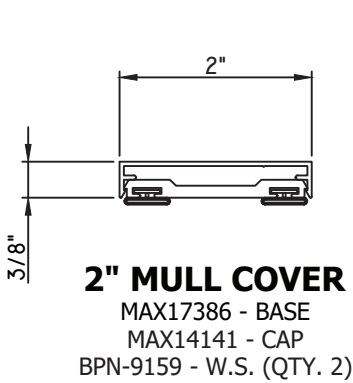

SCALE 1:2

Our products are tested to the standards of and certified by some of the foremost organizations in the fenestration industry.



All information seen within this document are considered current. However periodic changes/updates to our products are necessary. Quaker Window Products Inc. reserves the right to change any information without notice.

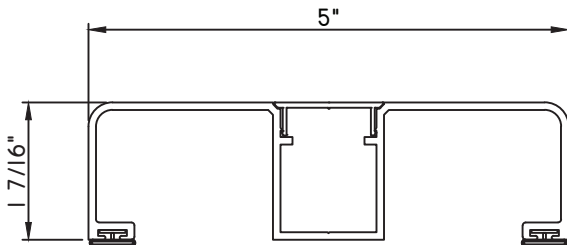

5 " MULL COVER
M23978 - MULL COVER
M536207 - CAP
BPN-9159 - W.S. (QTY. 2)

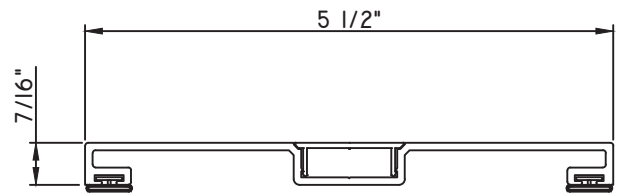

5 1/2" MULL COVER
M536206 - MULL COVER
M536207 - CAP
BPN-9159 - W.S. (QTY. 2)

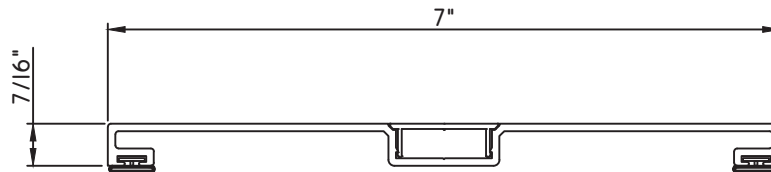

7" MULL COVER
M12794 - MULL COVER
M536207 - CAP
BPN-9159 - W.S. (QTY. 2)

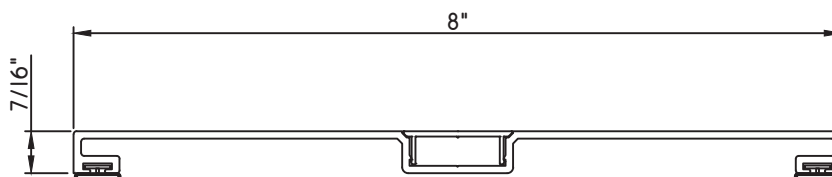

8" MULL COVER
M23410 - MULL COVER
M536207 - CAP
BPN-9159 - W.S. (QTY. 2)

SCALE 1:2

Our products are tested to the standards of and certified by some of the foremost organizations in the fenestration industry.

