

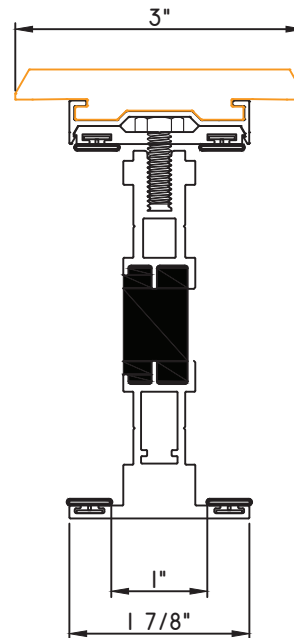

W600/W605 Series Casement, Project-Out, Fixed Vertical Mulls

All information seen within this document are considered current. However periodic changes/updates to our products are necessary. Quaker Window Products Inc. reserves the right to change any information without notice.

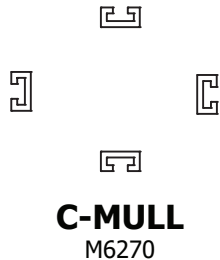

T-MULL

- M23060 - T-MULL
- M23056 - BASE
- M23057 - CAP
- 109474 - WOOD CAP
- M13404 - L-ANGLE (QTY. 2)
- BPN-9159 - W.S. (QTY. 4)
- MH1/4 20X3/4 - BOLTS (18" APROX. O.C.)
- 5228 - ANCHOR (QTY. 2) (NAIL FIN)
- M18231 PCS - ANCHOR (QTY. 2) (RECEPTOR)
- MPS-8X1 1/2 - FASTENERS (QTY. 2)

CAN ONLY BE USED WITH W600

Our products are tested to the standards of and certified by some of the foremost organizations in the fenestration industry.





W600/W605 Series Casement, Project-Out, Fixed Vertical Mulls

All information seen within this document are considered current. However periodic changes/updates to our products are necessary. Quaker Window Products Inc. reserves the right to change any information without notice.

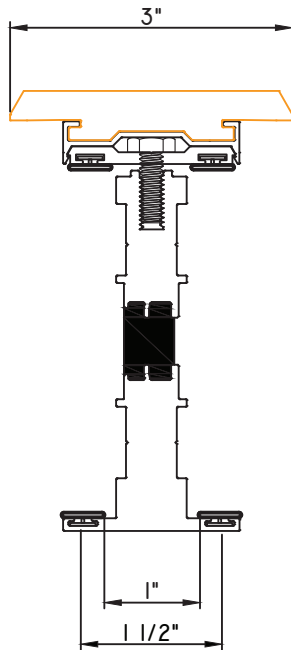

T-MULL

- M24501 - T-MULL
- M23056 - BASE
- M23057 - CAP
- 109474 - WOOD CAP
- M13404 - L-ANGLE (QTY. 2)
- BPN-9159 - W.S. (QTY. 4)
- MH1/4 20X3/4 - BOLTS (18" APROX. O.C.)
- 5228 - ANCHOR (QTY. 2) (NAIL FIN)
- M18231 PCS - ANCHOR (QTY. 2) (RECEPTOR)
- MPS-8X1 1/2 - FASTENERS (QTY. 2)

CAN ONLY BE USED WITH W600

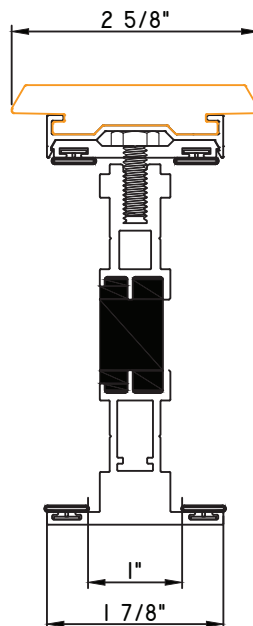

T-MULL

- M23060 - T-MULL
- M23056 - BASE
- M23057 - CAP
- 110162 - WOOD CAP
- M13404 - L-ANGLE (QTY. 2)
- BPN-9159 - W.S. (QTY. 4)
- MH1/4 20X3/4 - BOLTS (18" APROX. O.C.)
- 5228 - ANCHOR (QTY. 2) (NAIL FIN)
- M18231 PCS - ANCHOR (QTY. 2) (RECEPTOR)
- MPS-8X1 1/2 - FASTENERS (QTY. 2)

CAN ONLY BE USED WITH W600

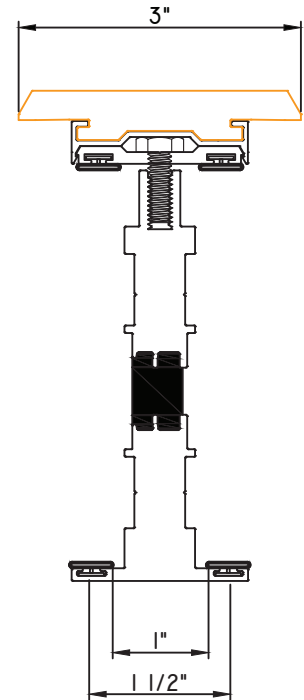

T-MULL

- M24502 - T-MULL
- M23056 - BASE
- M23057 - CAP
- 109474 - WOOD CAP
- M13404 - L-ANGLE (QTY. 2)
- BPN-9159 - W.S. (QTY. 4)
- MH1/4 20X3/4 - BOLTS (18" APROX. O.C.)
- 5228 - ANCHOR (QTY. 2) (NAIL FIN)
- M18231 PCS - ANCHOR (QTY. 2) (RECEPTOR)
- MPS-8X1 1/2 - FASTENERS (QTY. 2)

CAN ONLY BE USED WITH W600

Our products are tested to the standards of and certified by some of the foremost organizations in the fenestration industry.





W600/W605 Series Casement, Project-Out, Fixed Horizontal Mulls

All information seen within this document are considered current. However periodic changes/updates to our products are necessary. Quaker Window Products Inc. reserves the right to change any information without notice.

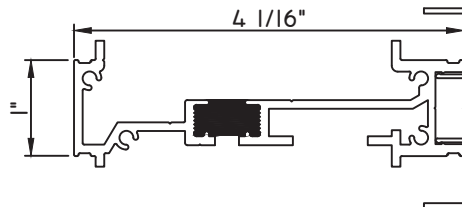

1" STACK MULL

M23841 - STACK MULL

M23843 - INTERIOR COVER

970-300 - WEEP COVER

QWP-M23844 - END DAM (QTY. 2)

MH8-18X1 LP - SCREW (QTY. 8)

W600 Install ONLY

SCALE 1:2

Our products are tested to the standards of and certified by some of the foremost organizations in the fenestration industry.

