

CityVu/CityLine/C200 TimberVu/TimberLine/W200 Sliding Door without Flashing Flange and Thermal Flashing Installation Guide

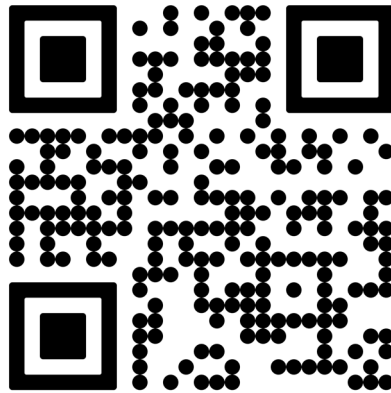

-Scan here for a digital version-

Part # IG-130 - V.1.0 6/10/2026

If this set of instructions does not match your installation method or the wall conditions of the job site, please call Quaker Customer Service for additional information.



Quaker Window Products
504 Highway 63 S
Freeburg, MO 65035
Phone: 800-347-0438
Fax: 573-469-4151
www.quakerwindows.com

Note:

While the details within these instructions are based on the C200 Standard Sill Sliding Door, the installation and sealing methods also apply to the Low Profile Sill Sliding Door. The 4/9 Option will be shown as the standard, but the 6/9 Option will be shown when required due to dimensional differences.

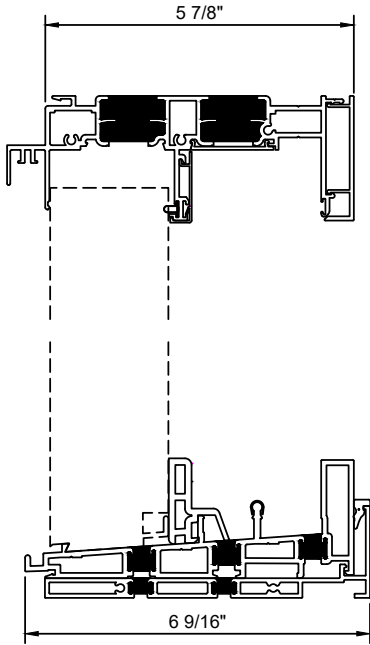

Standard 4/9 Sill Fixed Side

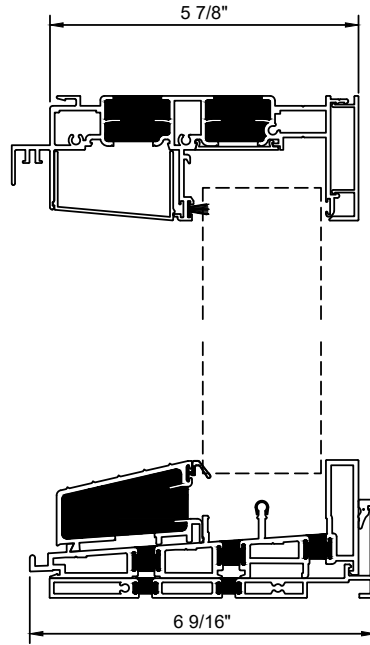

Standard 4/9 Sill Operable Side

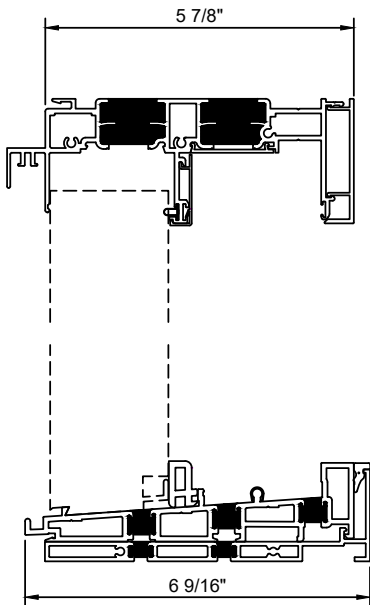

Low Profile 4/9 Sill Fixed Side

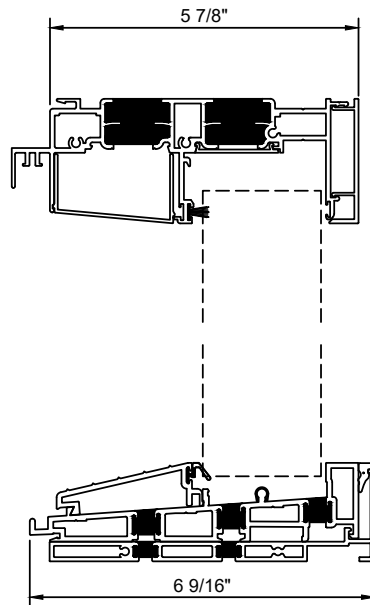

Low Profile 4/9 Sill Operable Side

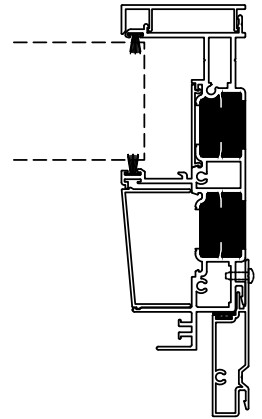
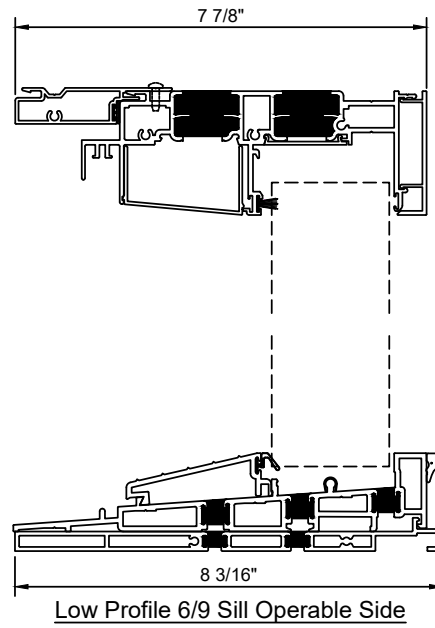
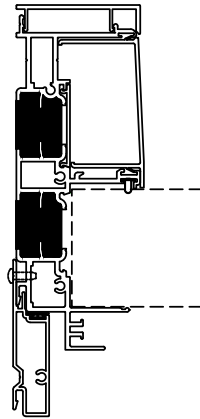
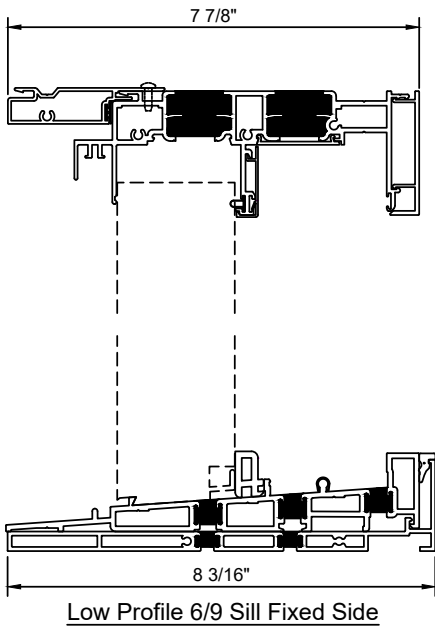
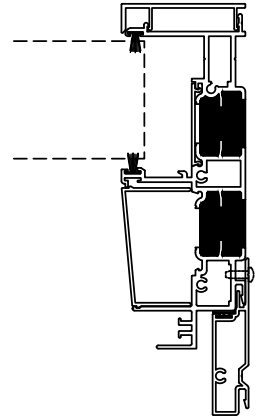
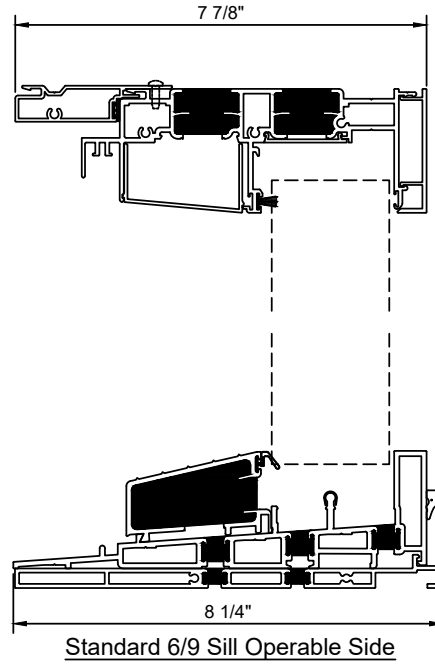
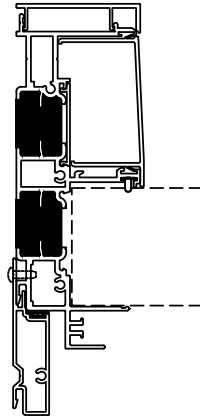
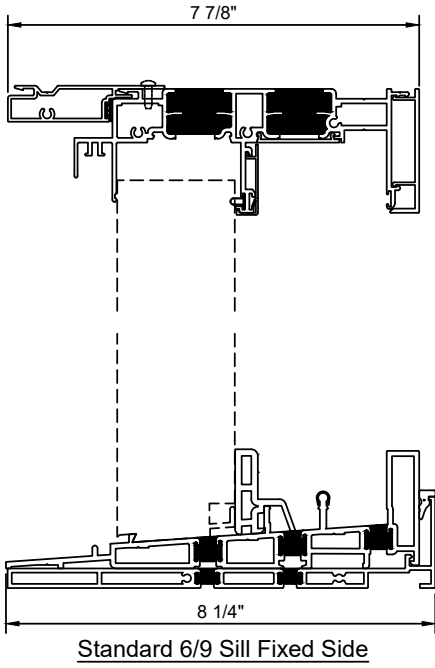

Tools Required by Installer

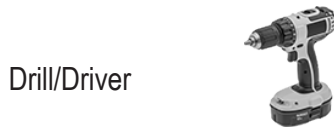

Materials Required by Installer

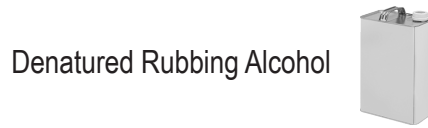
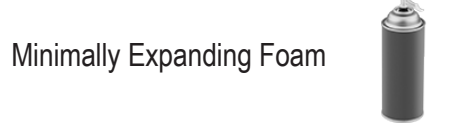
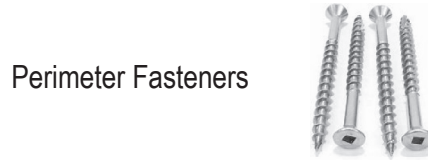
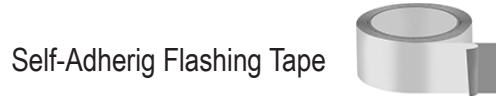

-Carefully read these instructions before starting any installation-

Failure to install and maintain QUAKER® products according to these instructions may void any product warranty. However, these are generic instructions that cover common situations and applications, aspects of which may not be appropriate for all installations due to building design, site conditions, construction materials, or installation methods used. Refer to shop drawings, if applicable, for additional notes and details. Please consult Quaker for specific applications not covered in these installation instructions, or visit our website at www.quakerwindows.com, or call 800-347-0438 for additional information.

Tools

- Follow manufacturer's instructions and safely operate tools, ladders, or scaffolding. Always wear safety glasses. Failure to do so could result in injury, product, or property damage.

Handling

- Do not store QUAKER products outside or in an unprotected, high moisture, or high heat environment prior to installation. Doing so could result in product damage.
- Do not carry, transport, or store QUAKER products in a flat (horizontal) position. Doing so could result in product damage or injury.
- Window and door units should be kept or stored in an upright (vertical) position, with support across the sill to avoid bowing. Do not lay any units in a flat position!

Glass

- If glass gets broken, please exercise caution, as glass fragments can cause lacerations or other injuries. In many areas, local building codes require safety glass to be used in certain applications. All QUAKER products are available with safety glass if they are ordered that way.

Fastening

- Metal fasteners and components could corrode when used in contact with preservative-treated lumber. Use approved and appropriate fasteners and components to fasten QUAKER products in this application. Failure to do so could result in a product performance failure, injury, or property damage.
- Quaker does not provide anchorage or fastener calculations.
- Quaker is not responsible for determining structural adequacy of the anchorage and fasteners used to install QUAKER products, or the openings into which they are installed.

Installation

- Report any damage to dealer immediately. Do not install product if damaged. Quaker is not responsible for addressing products that are damaged after delivery, or product that is installed in a damaged condition.
- Always support window or door products in an opening until fully fastened. Failure to do so could result in the product falling out of an opening and causing injury, product, or property damage.
- Nailing flanges and drip caps (integral or applied) do not take the place of window flashing. All QUAKER products must be properly flashed and sealed with material compatible sealant for protection against water and air infiltration around the entire exterior perimeter. Failure to do so could result in a product installation failure and property damage.
- Windows and doors must be properly shimmed. To properly shim a QUAKER product, follow relevant installation guidelines, and never set a window directly on a sill plate. Failure to shim properly is an installation failure that could result in product performance failure or property damage.
- Construction directly above an opening must be engineered and designed not to transfer loads directly to any windows or doors. If live or dead loads are transferred to a QUAKER product, this may affect functionality and result in glass failure or otherwise damage frame joinery, perimeter seals, or other aspects of the product. Proper construction of the rough opening must take place prior to the installation of the QUAKER product.
- Please confirm that any necessary vertical deflection of the head condition is consistent with the selected QUAKER product. Most QUAKER products are not designed to allow any deflection at the head condition. Shop drawings may indicate the maximum allowable vertical deflection at the head condition of a QUAKER product. If vertical deflection is a concern but shop drawings are not provided, please contact Quaker for assistance.
- Windows and doors have small parts that, if swallowed, could pose a choking hazard to young children. Please dispose of unused, loose, or easily removed small parts. Failure to do so could result in injury or death.
- Do not drill through or into the sill or frame of any QUAKER products, whether to install alarm wires or for any other reason.
- During installation and positioning of any window or door products with an aluminum frame, make sure to align the thermal break of the product, with the insulation plane or air barrier of the building itself, in order to maintain continuity and integrity of the thermal envelope, and prevent thermal bridging that leads to excessive thermal transfer and/or condensation. In other words, the thermal break of the product must be recessed from the exterior plane of the wall opening, remain fully embedded within the wall opening, and not be exposed directly to exterior elements.

Sealing

- Follow supplier instructions for proper application of minimally expanding foam, sealant, water resistant barrier or liquid barrier, and flashing products and systems to ensure safety, proper material application, compatibility, and to understand the need for periodic maintenance for continued weather resistance of their products. Failure to do so could result in product performance failure or property damage.
- Minimally expanding foam insulation must be compliant with AAMA 812.
- If silicone is selected as an appropriate sealant, Quaker recommends using 100% neutral cure silicone sealant, that is ASTM C920 compliant. Always clean and prepare the surfaces where the sealant will be applied per the manufacturer's recommendation. Once applied, properly tool the sealant in place. Failure to do so could result in product performance failure or property damage.
- Flashing tape must meet ASTM-D779 performance requirements.
- Maintain and properly seal a minimum of 1/4" gap (or whatever is specified within these installation instructions or shop drawings) around the perimeter of the window or door frame and the exterior finish materials. Failure to do so could result in product installation failure or property damage.

Joining

- Do not join any Quaker product to another product that is not designed for joining. Joined products must be individually supported in the opening. Failure to do so could affect operation and product performance and could result in a product installation failure or property damage.

Cleaning

- Do not use any cleaning agent other than a mild, non-abrasive window washing solution or glass cleaner applied in accordance with any product labeling instructions and Quaker's care and maintenance instructions. The use of harsh chemicals (such as brickwash, bleach, alcohol, hydrochloric acid, or muriatic acid) for cleaning or other purposes may damage QUAKER products, glass, fasteners, hardware, seals, sealant, or metal flashing. Please protect these products by following the cleaning product's instructions for its proper use.
- Do not use a razor blade to clean a glass surface, as damage to the glass may result.

IMPORTANT

- Buildings constructed prior to 1978 may contain lead paint which could be disturbed during window or door replacement. For more information on proper management of lead paint, go to: www.epa.gov/lead
- Care must be taken to properly recycle or dispose of used or old materials. Any recyclable material should be separated from non-recyclable or hazardous materials. Please consult with local or state authorities regarding proper disposal of non-recyclable or hazardous materials.
- Inspect all window and door units for any damage or defects prior to installation. Contact the nearest QUAKER distributor if there are any problems or issues.
- **WARNING:** This product can expose you to chemicals, including titanium dioxide or methanol, which are known to the State of California to cause cancer and birth defects or other reproductive harm. For more information go to www.P65Warnings.ca.gov
- **WARNING:** Drilling, sawing, sanding, or machining wood products can expose you to wood dust, a substance known to the State of California to cause cancer. Avoid inhaling wood dust or use a dust mask or other safeguards for your personal protection. For more information go to www.P65Warnings.ca.gov
- When installation is completed, operable window and door products, and related hardware or equipment, may require some adjustments. Confirming operability and making minor adjustments are within the scope of the installation services performed by others.
- **WARNING - OVERHANG NEEDED:** It is recommended that doors (swing and sliding) with ADA or Low-Profile Sills be installed with an overhang depth equal in length to the height of the door. If you choose to use an overhang depth less than the height of the door, you must confirm that it is appropriate based on code requirements and the expected local wind and rain conditions.

Verify Header Support

Ensure the structure over the door system is fully supported. Take into account the weight of all materials above the door system, because this may cause deflection. No more than 1/8" deflection is allowed.

Confirm that all materials and fasteners are adequate for all load requirements.

If you have any questions, please feel free to call Quaker Windows 1 (800) 347-0438

Before installing the frames and panels, unpack all parts and place near the opening. Make sure you have all parts according to the packing slip and check for any damaged parts.

Note:

The 4/9 Option will be shown as the standard, but the 6/9 Option will be shown when required due to dimensional differences.

WB1

From the interior, measure and verify the size of the rough opening. The rough opening should be a minimum 1/2" wider and taller than the Window Unit (but do not exceed 1"). Verify the rough opening is flat, plumb, level, and square. Take diagonal measurements to check for square. The sill plate beneath the unit must be level for proper unit operation. Go to the exterior and cut the Weather-Resistant Barrier (WRB) in an 'T' pattern.

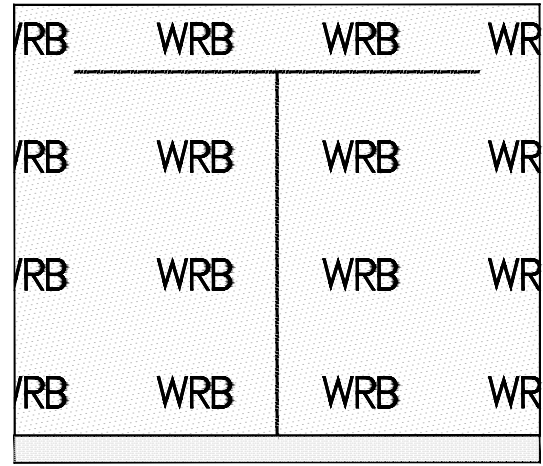
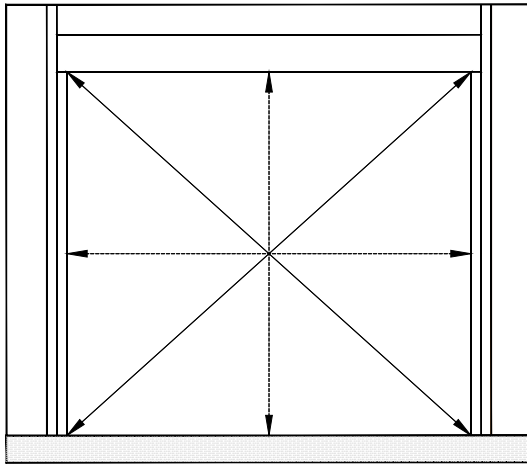

WB2

Fold the WRB sides towards the interior and trim as needed. Do not staple in place. Make 4"-6" horizontal cuts in the WRB at the head and sill jambs. Make a 45° x 6" long cut at the head condition. Fold back WRB at the cut lines, and tape into place.

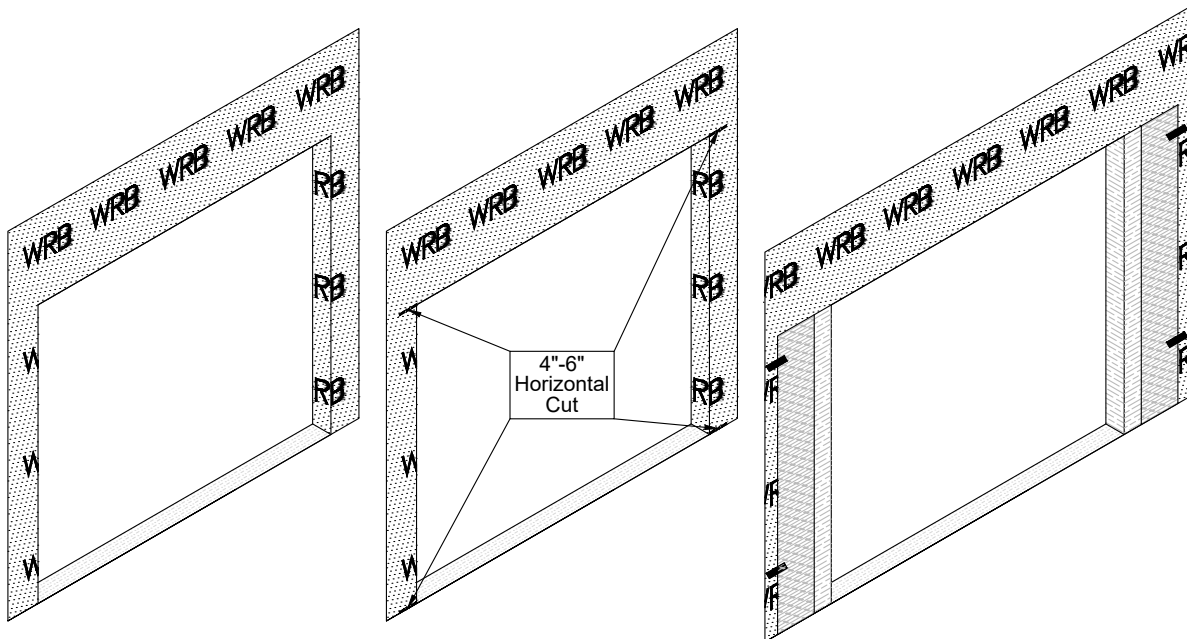

WB3

Measure the width of the rough opening, and cut two (2) lengths of self-adhering flashing that is 12", or more, than the width of the rough opening. This will allow the flashing to run 6"+ up/down each jamb condition. Apply the flashing to the exterior sill side first, allowing for a minimum of 3" below the sill and up each side. The flashing tape must cover the entire sill plate. Then apply the flashing to the exterior head side first, allowing for a minimum of 3" above the head and down each side. The flashing tape must cover the entire head member. If needed, apply an additional piece of flashing over the first one with a 1" minimum over-lap. Start from the exterior and work towards the interior. After applying the sill/head flashing, apply sealant at the jambs where shown. Fold the WRB jamb flaps back into place, over the sill flashing, and fix into place.

Leave head flap in place.

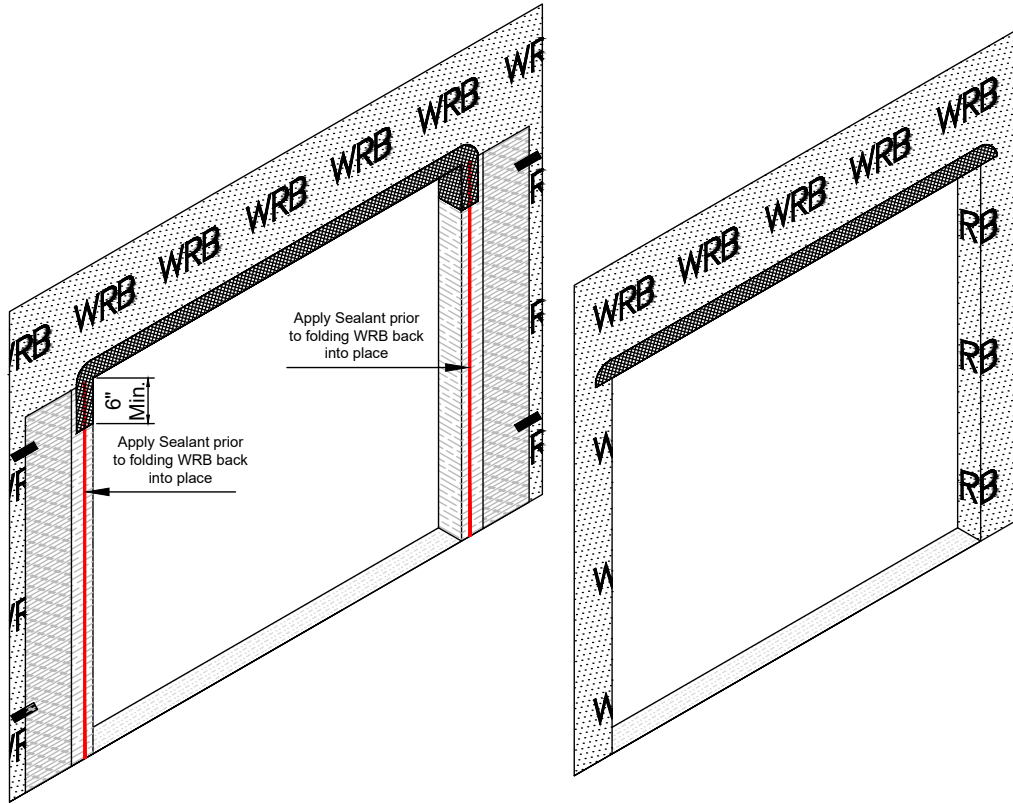

THIS INSTRUCTION IS FOR THE 4/9 and 6/9 OPTIONS

Dry fit the Sill Pan system within the opening, leaving a minimum 1/8" at each end. Check to see if the Sill Pan is level, and if not, be prepared to level area. Quaker first recommends **self-leveling concrete**.

If not available, use plastic shims as needed to ensure system is level.

4/9 System

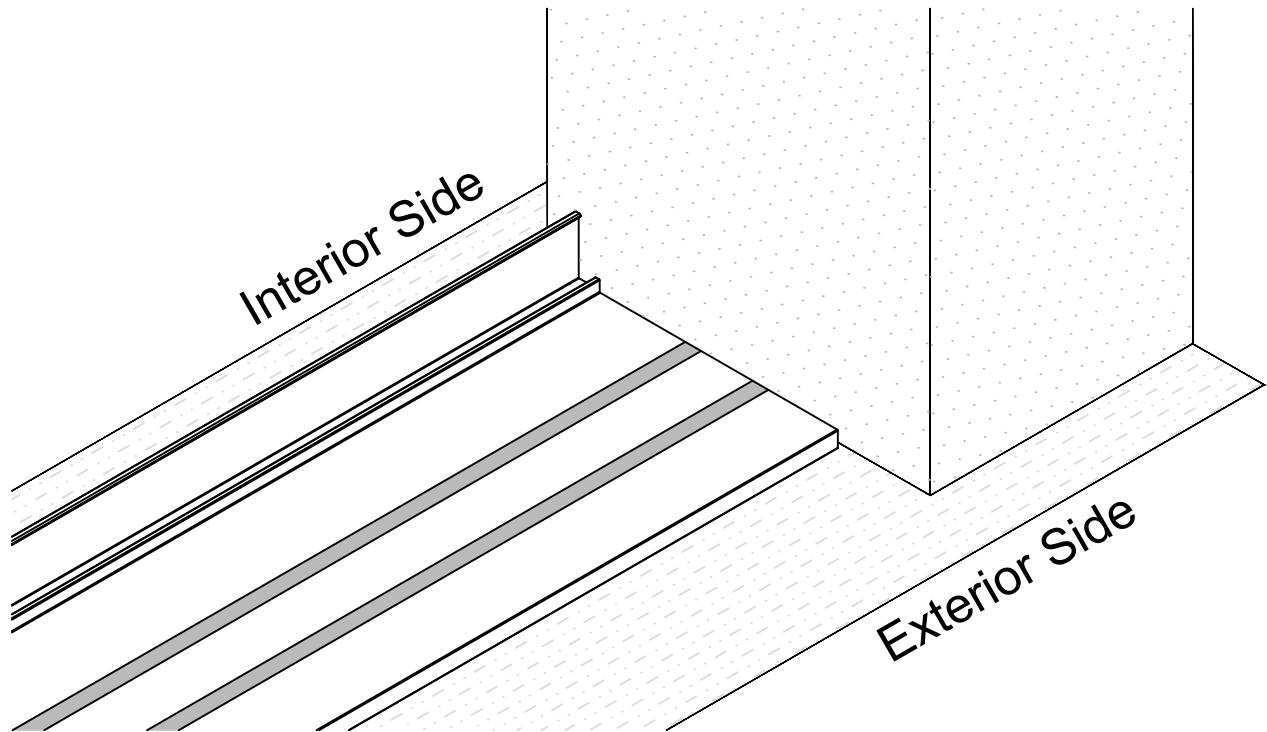

6/9 System

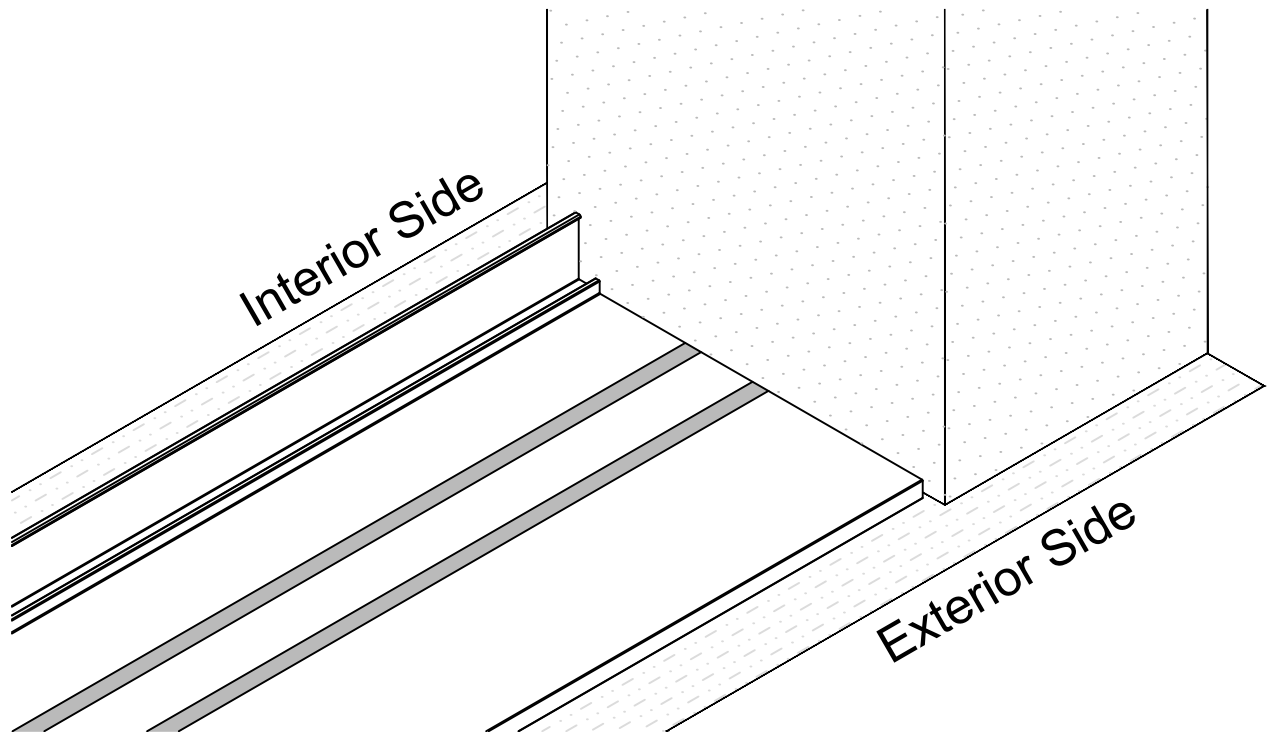

Frame Assembly

Assemble the frame to make sure the size is correct. Assemble on a protected surface.

-Some included and required weathering not shown for clarity-

These instructions are based on 1-Direction Sliding Doors (XO). If any other panel configuration is used, the jamb installation will remain the same or similiar. If needed, additional details and instructions will be provided.

Panel installation will remain the same.

FA1

At the Head and Jamb Frames, clean the end surfaces with IPA Alcohol, then use silicone sealant on the ends. Place the gasket (Part #QWP-CG34) on each face profile of the Frame Header.

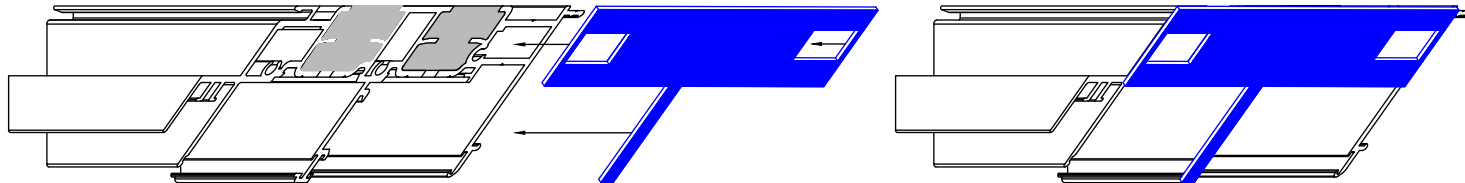

FA2

Place (2) of the Corner Keys (Part # FE_25-7x10-35-DT) to the top end of both frame jambs, and join to the header frame. Trim the gasket flush to both ends. Use the supplied screws (Part # FE FAST2) to attach the frame head to the frame jamb through the Corner Keys. Seal over the screw heads.

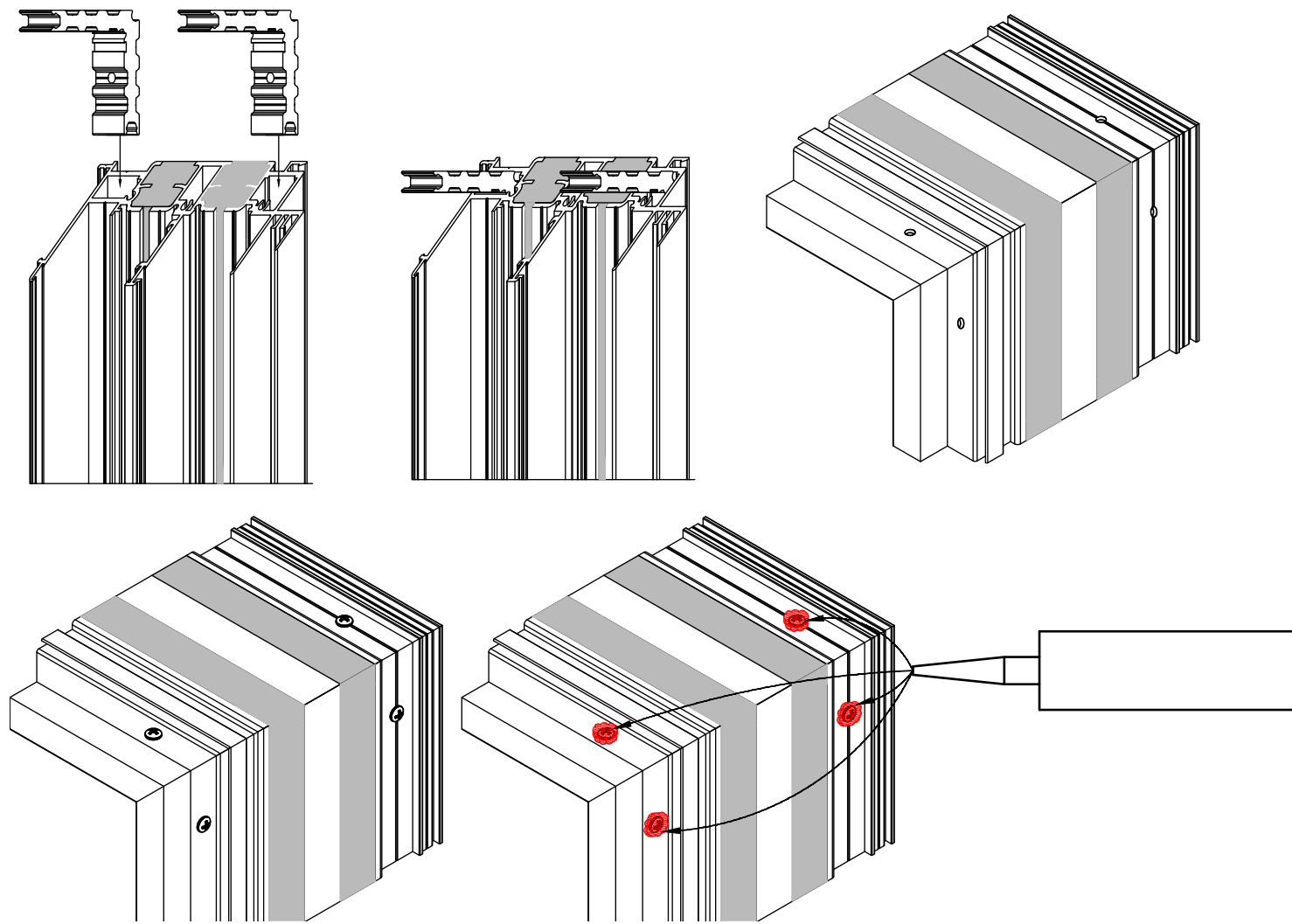

FA3

At the Sill and Jamb Frames, clean the end surfaces with IPA Alcohol, then use silicone sealant on the ends. Place the gasket (Part #QWP-CG35) on each face profile of the Jamb Frames.

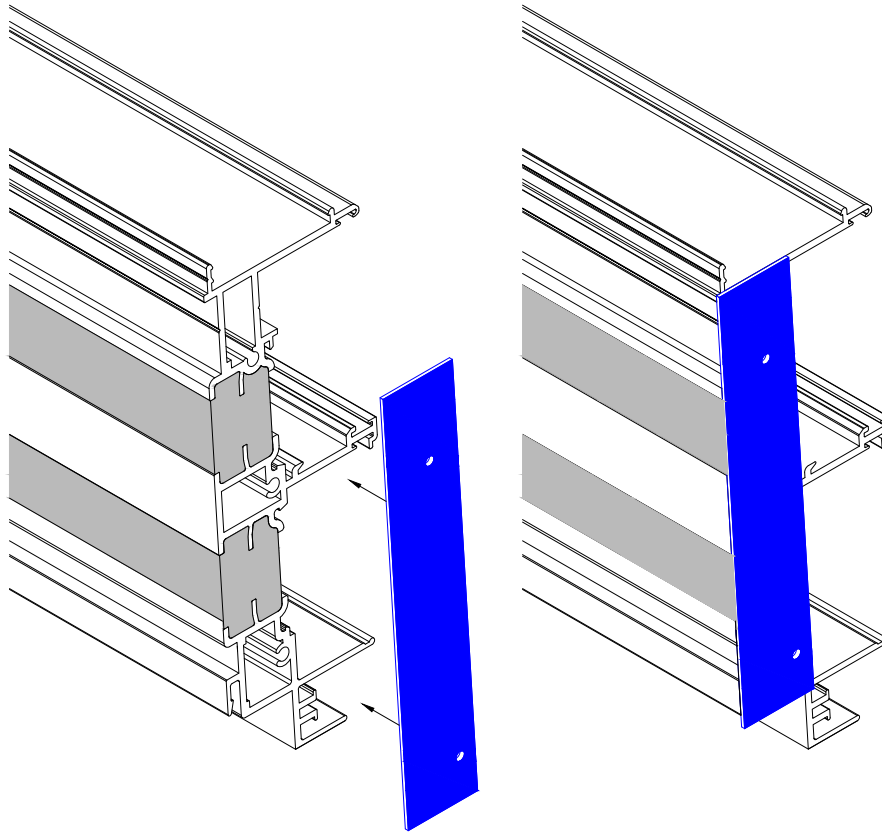

FA4

Attach the Jamb Frames to the Sill Frame with the supplied screws (MSP10AX1-SUB).
BE CAREFUL NOT TO BREAK SCREWS-SET IMPACT TO LOWEST SETTING
After attaching, apply silicone sealant to the back (outside) of the Sill and Jamb Frame joint. Tool in place.

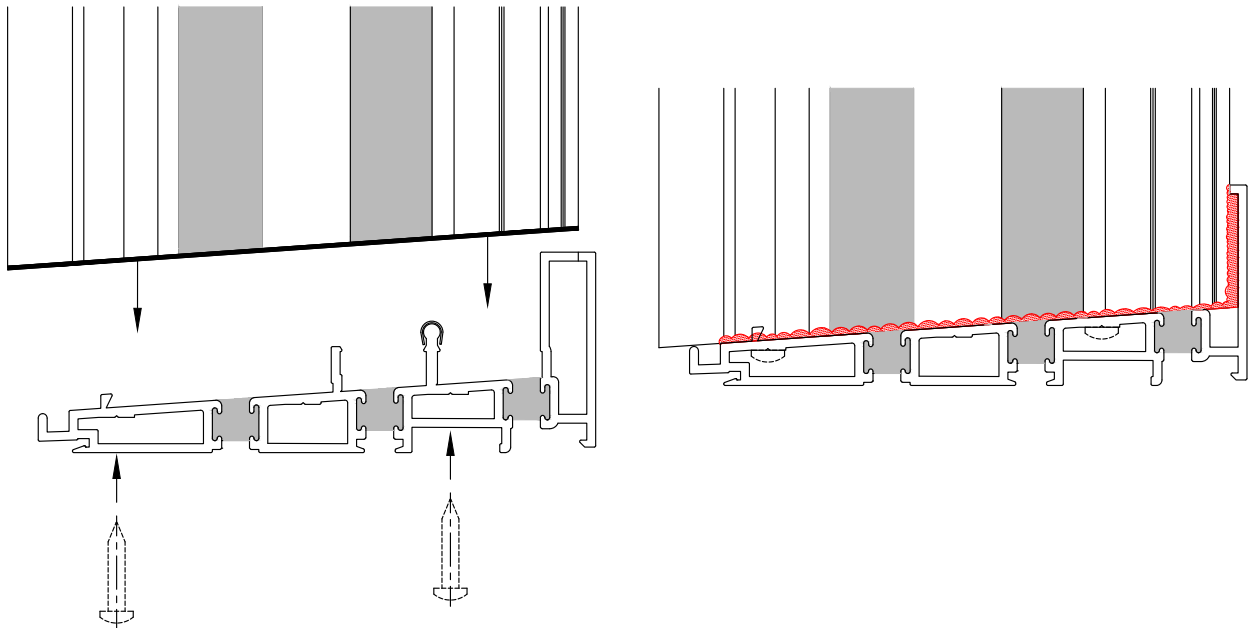

FA5

Drill pilot holes through the center track area of the Frame Header & Jambs per shop drawings or anchorage calculations. Typically, 6" from ends and 24" O.C.

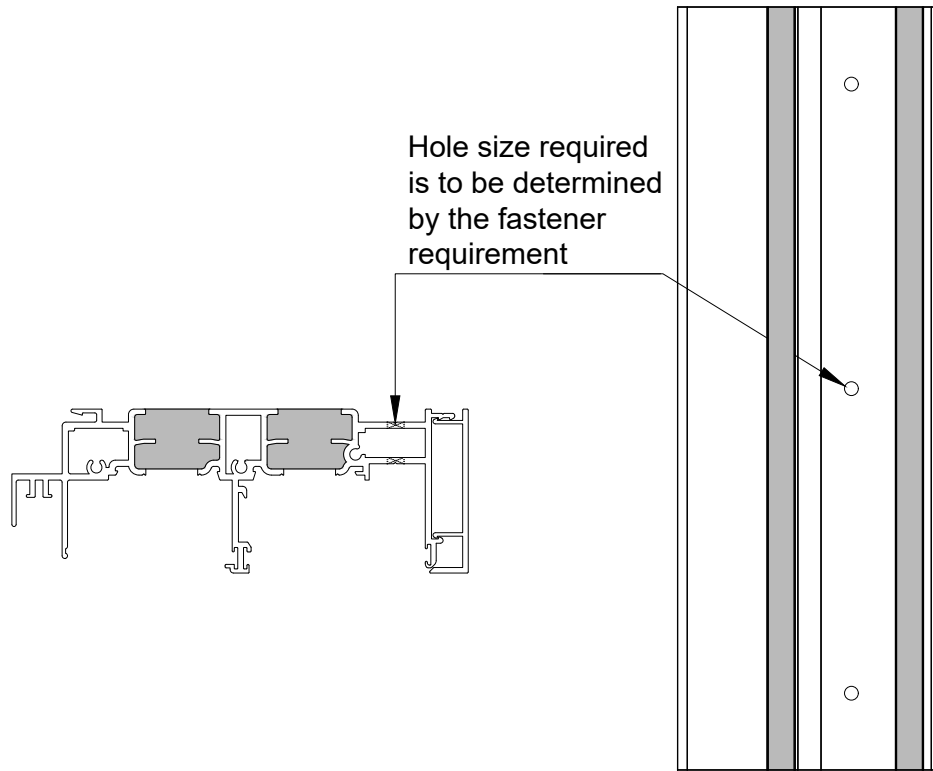

Sill Pan Installation for 4/9 Option

-See page 15 for 6/9 Option-

SP1A

Apply (3) 1" continuous beads of sealant across the entire width of the rough opening sill where the Sill Pan will set. Apply a 3/8" bed of sealant the depth of the Sill Pan being used, 1/2" from each side of the opening at the jambs.

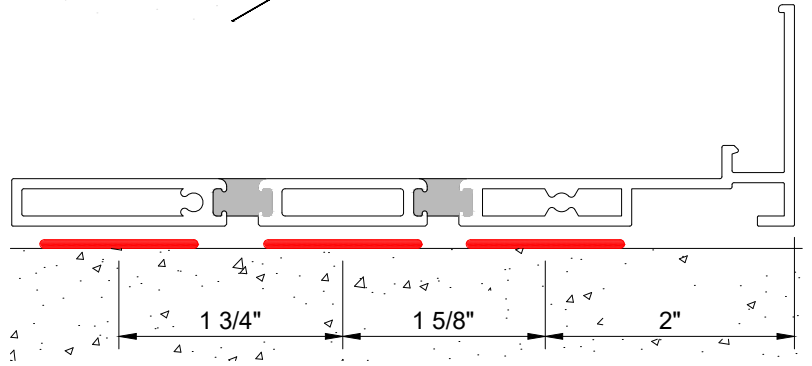
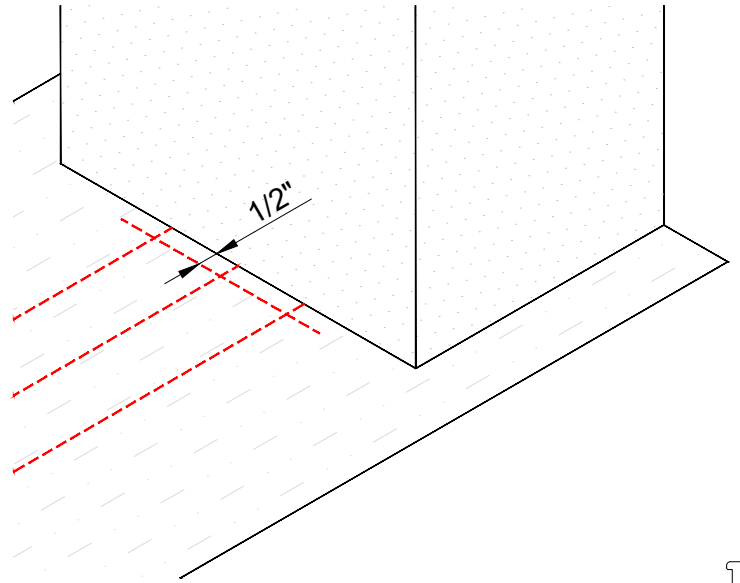
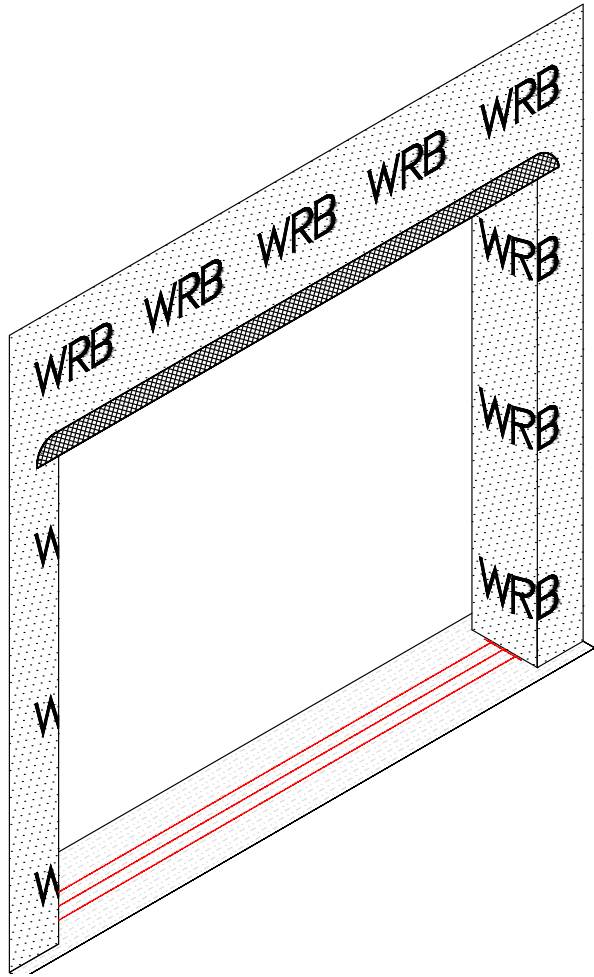

SP2A

Drill clear holes in the Sill Pan at the 'V' Groove. Drill bit size is determined by required screw size. Drill 3" from ends, and then at 14" O.C. Place the Sill Pan in place and allow a 1/8" gap between the rough opening and the Sill Pan at both jambs. Tool sealant at the interior and exterior as needed.

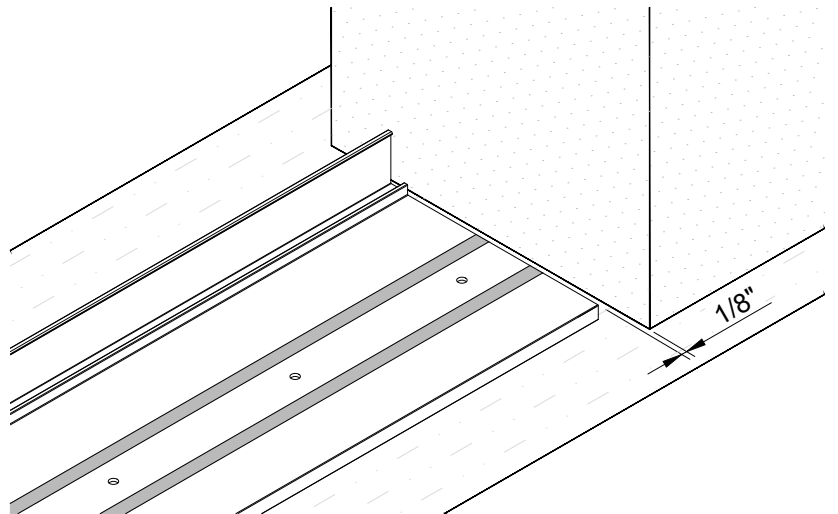
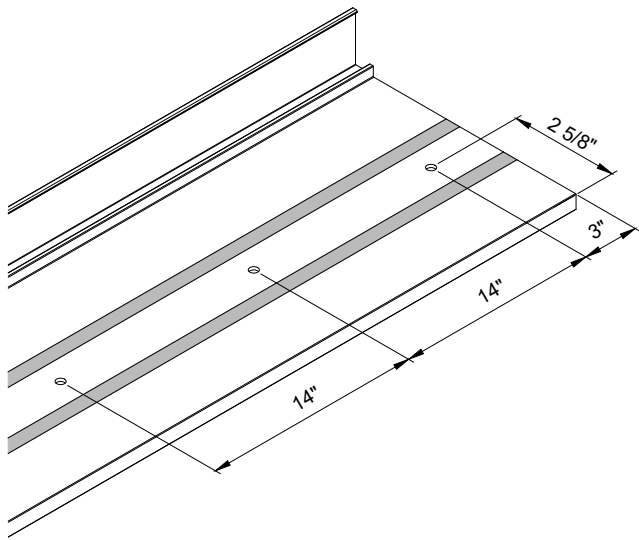

SP3A

Match drill into the surrounding conditions, then fill holes with sealant.
If needed, add support for Sill Frame. This support can be supplied by the installer, or Quaker Angle Bracket M4965-PCS.

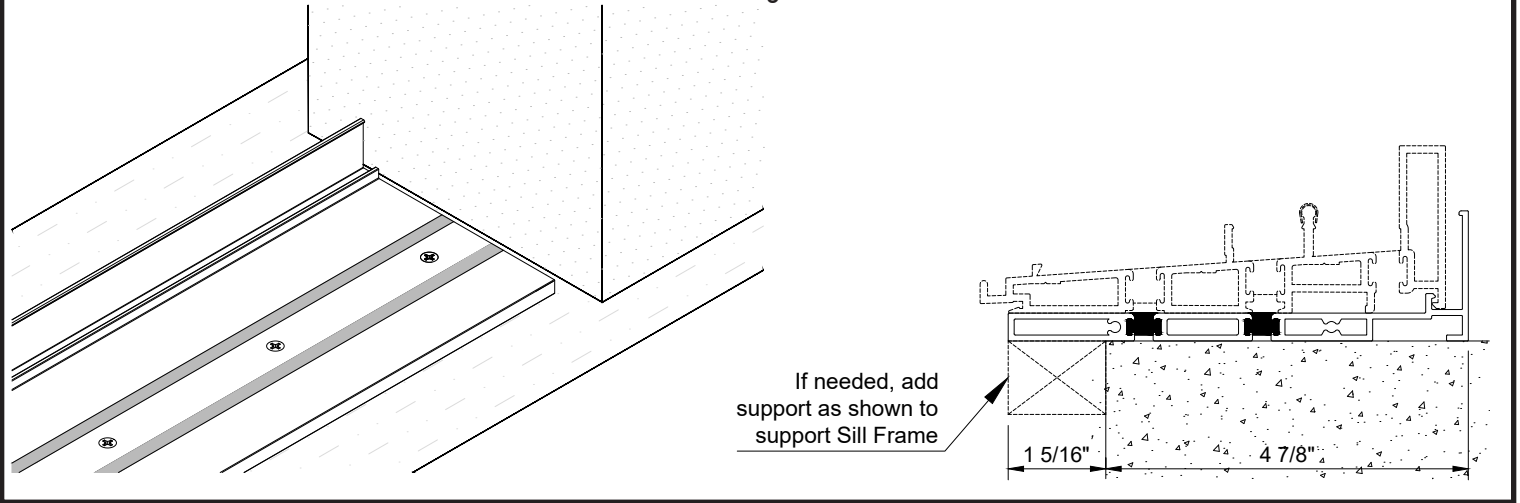

SP4A

Fasten the Sill Pan in place.
After installing the perimeter fasteners, apply silicone over the screw heads.

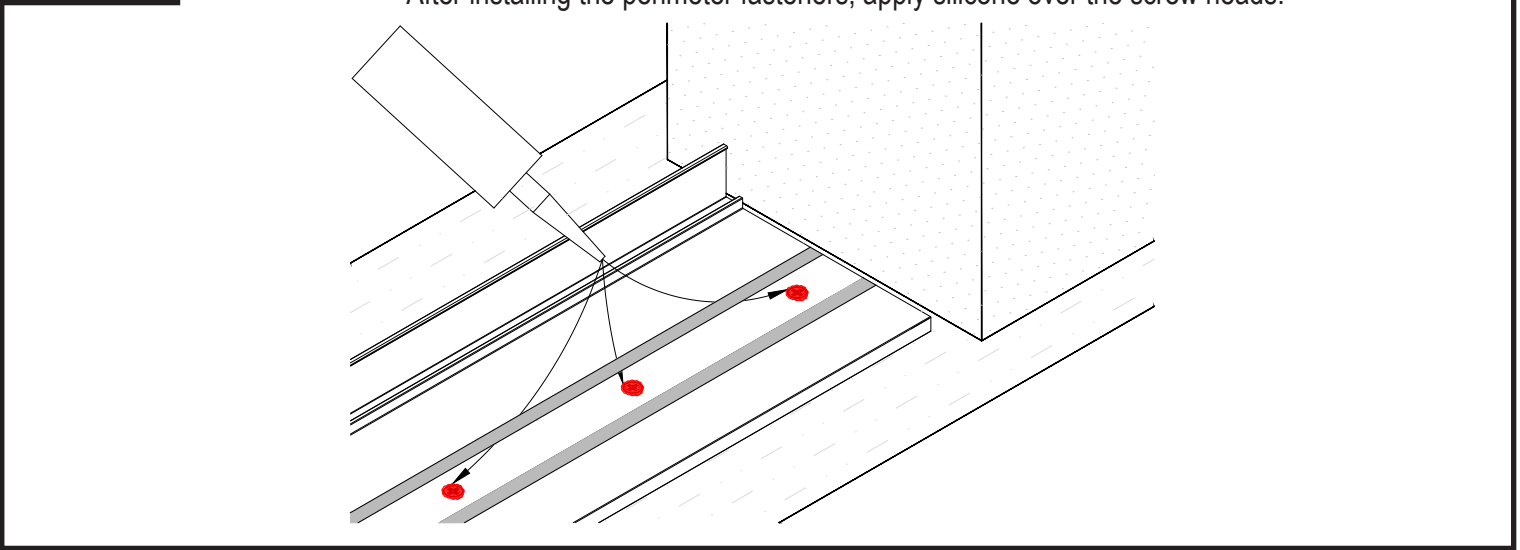

SP5A

With the Sill Pan in place, apply silicone sealant along the Sill Pan and along the upturn leg.

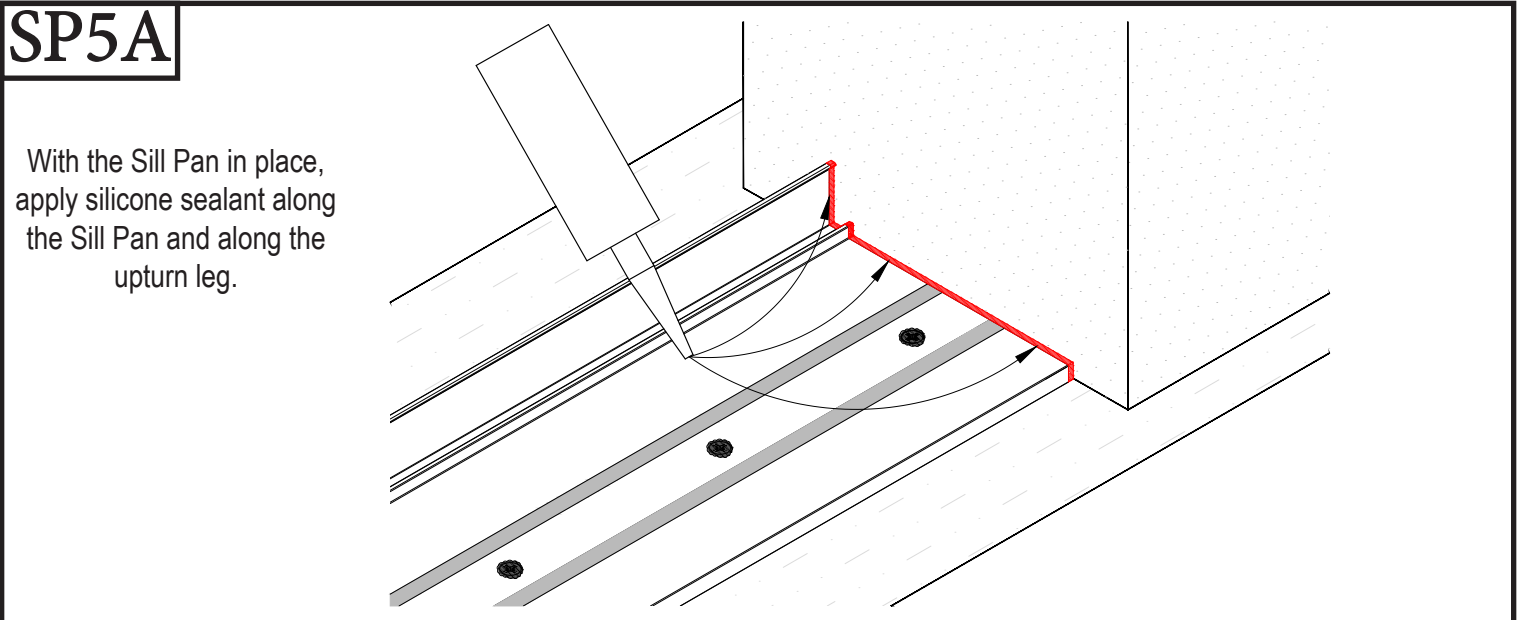

Sill Pan Installation for 6/9 Option

-See page 13 for 4/9 Option-

SP1B

Apply (3) 1" continuous beads of sealant across the entire width of the rough opening sill where the Sill Pan will set. Apply a 3/8" bed of sealant the depth of the Sill Pan being used, 1/2" from each side of the opening at the jamb.

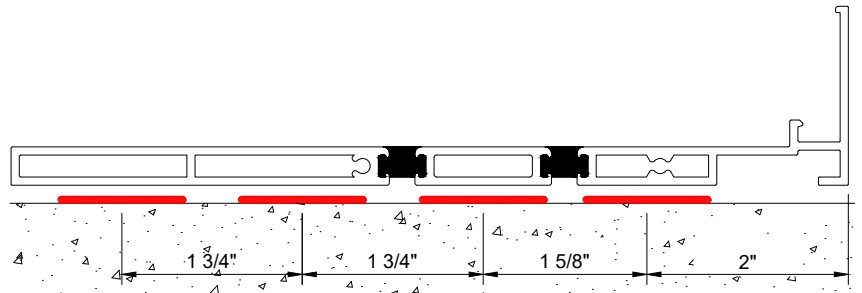
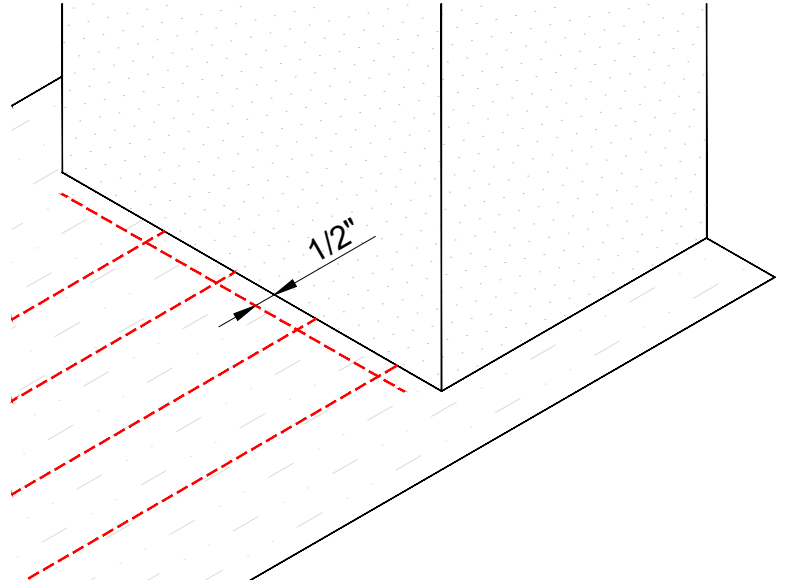
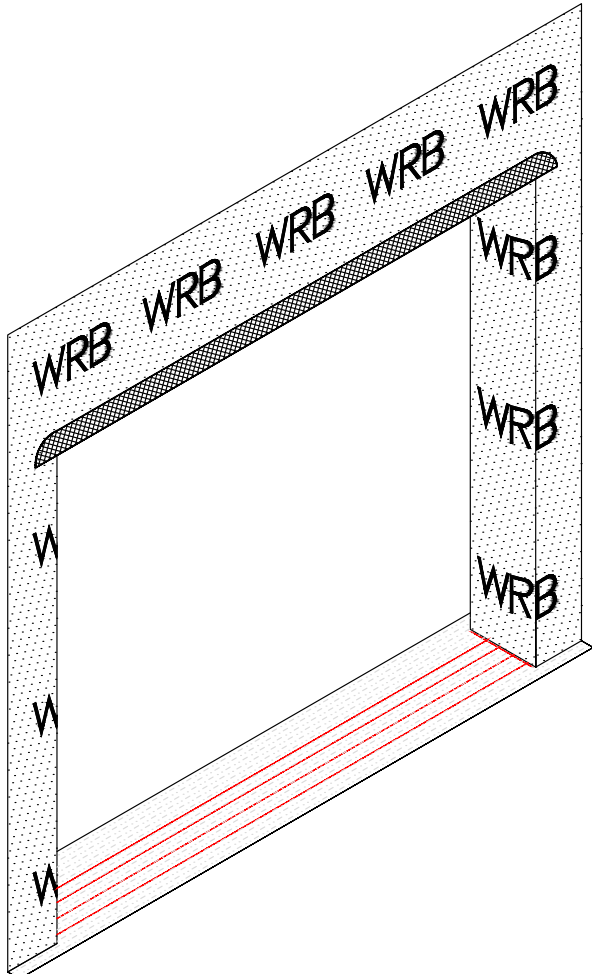

SP2B

Drill clear holes in the Sill Pan at the 'V' Groove. Drill bit size is determined by required screw size. Drill 3" from ends, and then at 14" O.C. Place the Sill Pan in place and allow a 1/8" gap between the rough opening and the Sill Pan at both jambs. Tool sealant at the interior and exterior as needed.

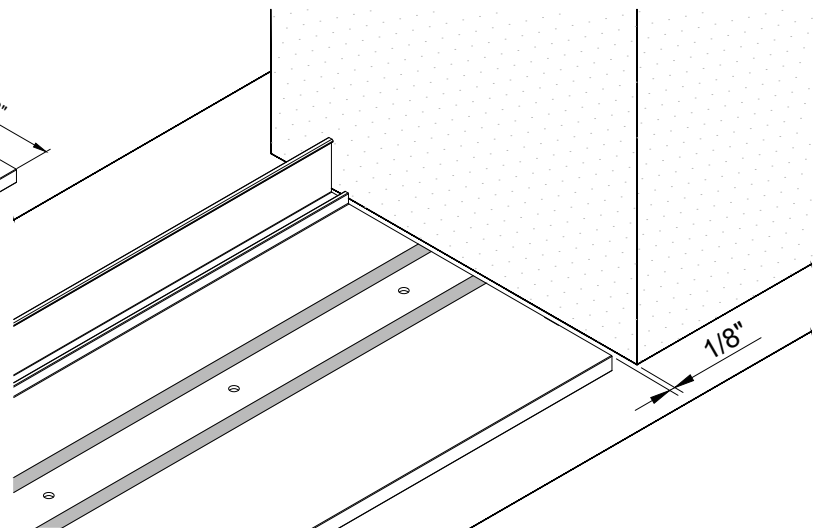
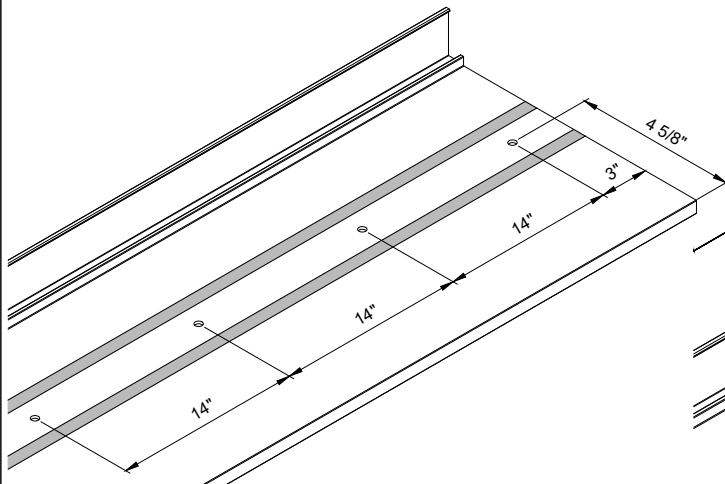

SP3B

Match drill into the surrounding conditions, then fill holes with sealant.
If needed, add support for Sill Frame. This support can be supplied by the installer, or Quaker Angle Bracket M4965-PCS.

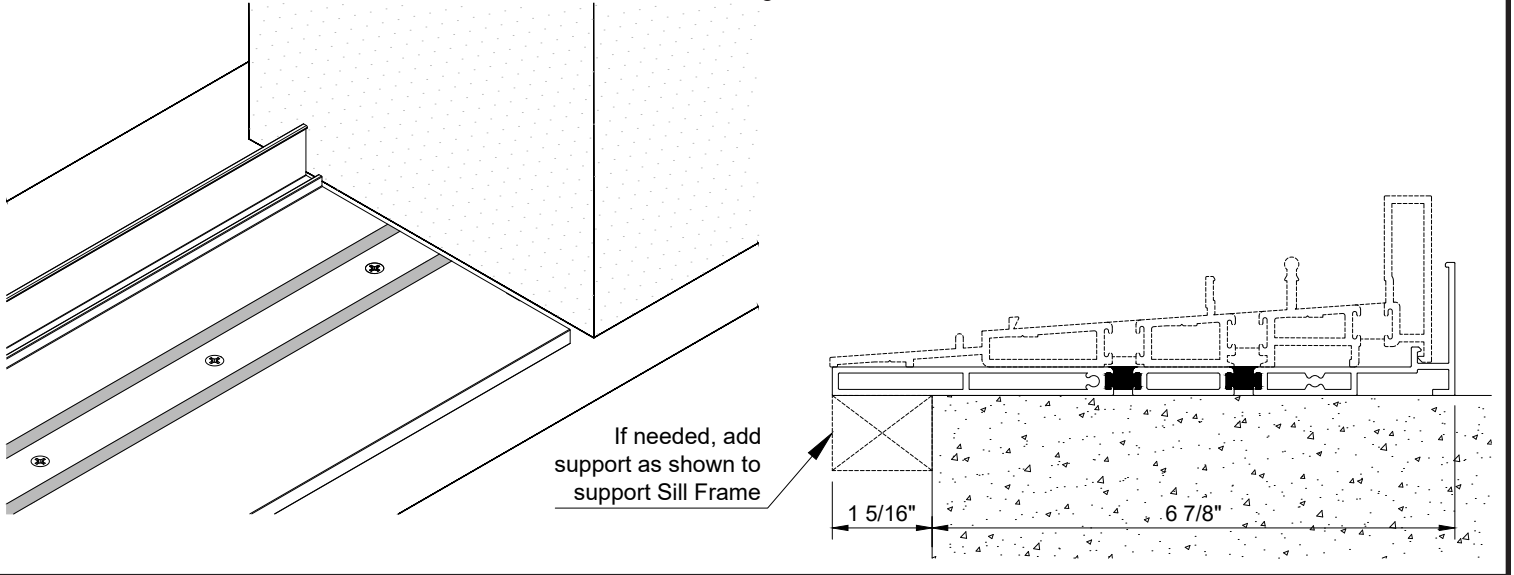

SP4B

Fasten the Sill Pan in place.
After installing the perimeter fasteners, apply silicone over the screw heads.

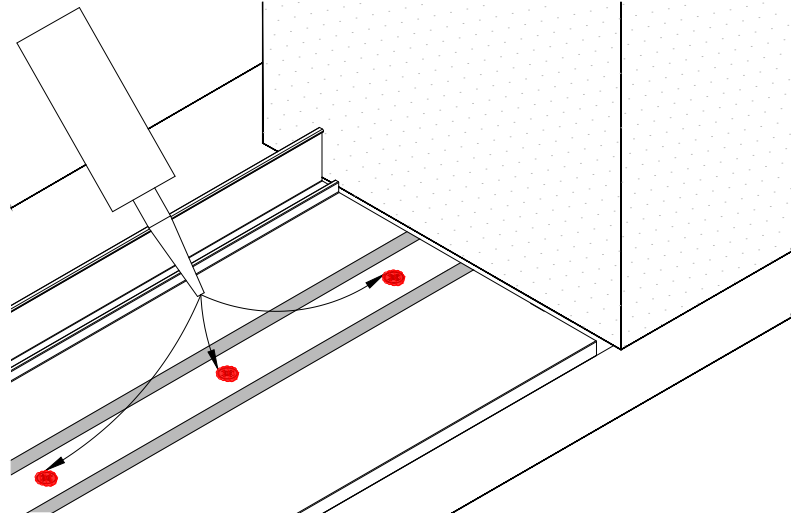

SP5B

With the Sill Pan in place,
apply silicone sealant along
the Sill Pan and along the
upturn leg.

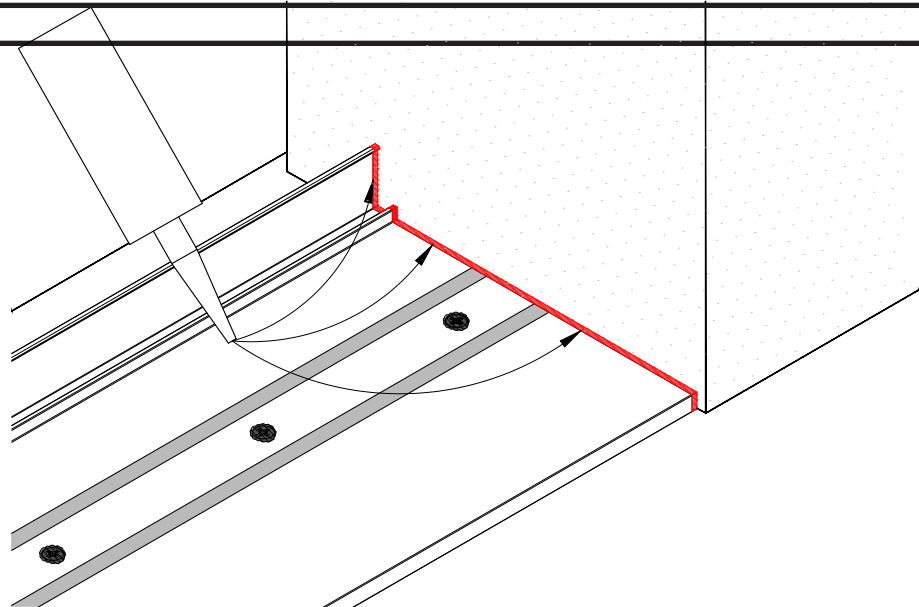

Frame Installation

FI1

Before inserting the frame assembly into the opening, run a bead of silicone sealant into the groove at the Sill Pan. The sealant should run jamb-to-jamb. Install the frame assembly by tilting top out and sliding it into the rough opening from the exterior side. Set the frame assembly onto the Sill Pan as shown below. Push the Wedge Gasket into place.

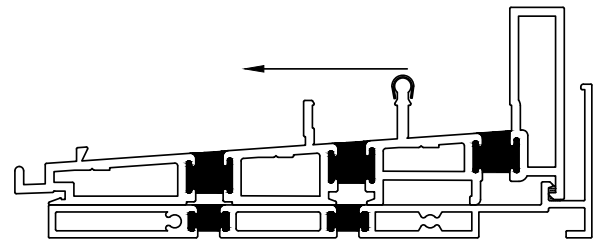
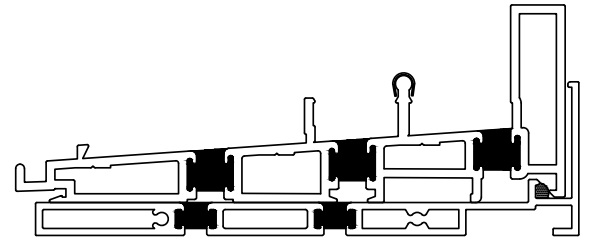
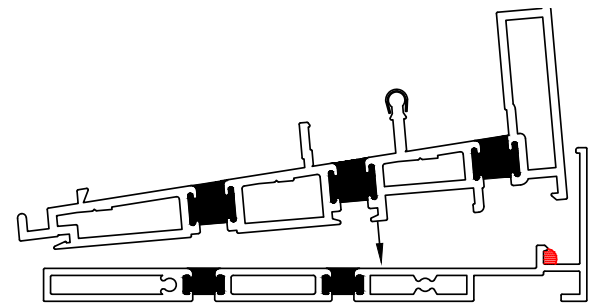
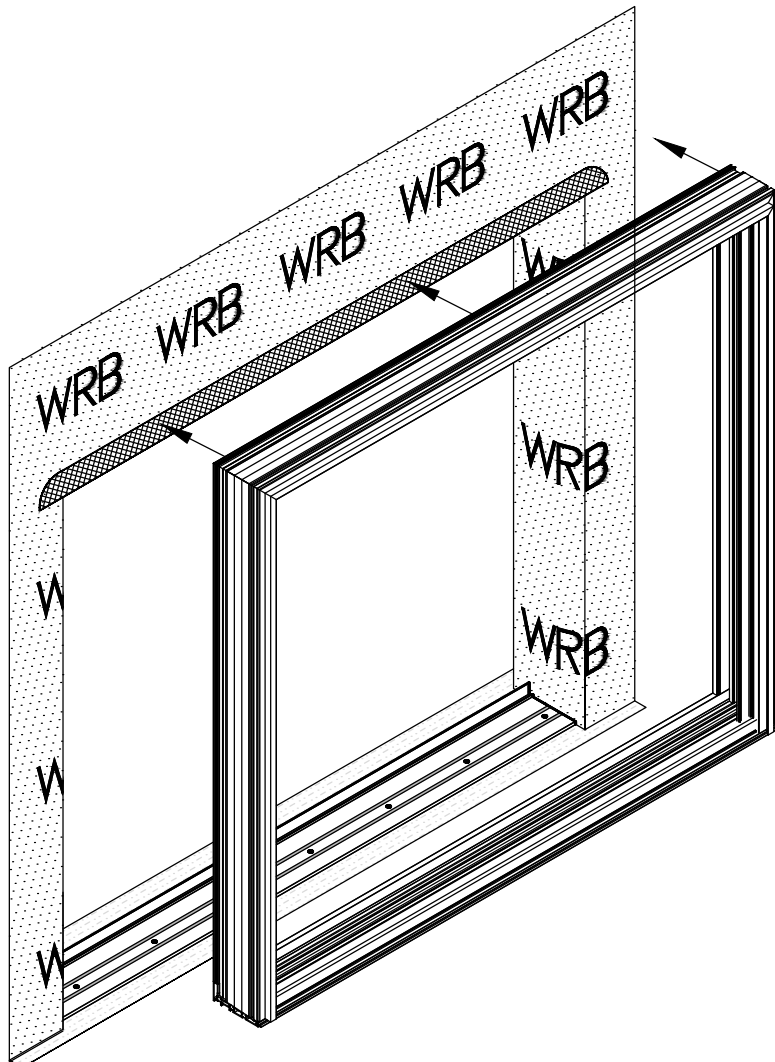

Wedge Gasket

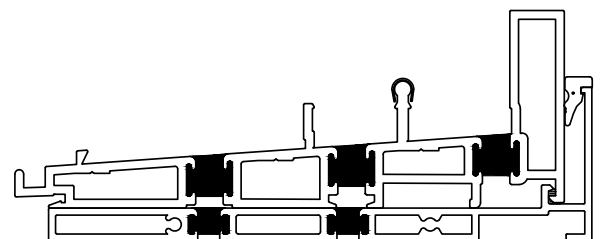
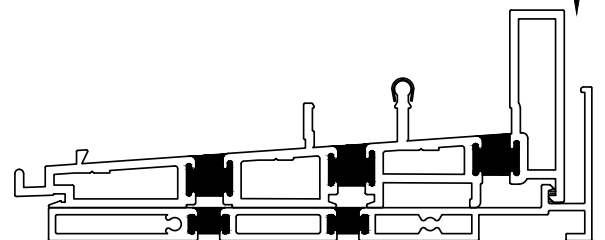

FI2

Verify head and jamb frames are level, plumb, and square. Use plastic shims as needed. Match drill into the surrounding conditions, and then fill holes with silicone sealant.

Temporarily insert required fasteners at the head and jamb frames just deep enough to hold the frame assembly in place.

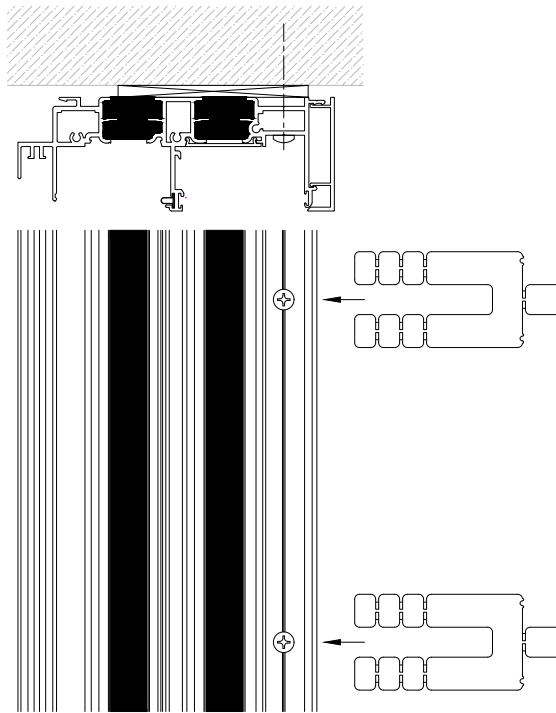

FI3

Before proceeding, again verify the frame assembly is level, plumb, and square. Measure diagonally, corner-to-corner, until the measurements are within 1/8" to each other. Adjust the plastic shims as needed. Measure vertically and horizontally at the 1/4 points to verify measurements are within 1/16" to each other.

Adjust the plastic shims as needed, then tighten all perimeter fasteners.

Verify the frame assembly is not bowed at the head or jambs.

Panel Installation

PI1

From the exterior, install the Active Panel by tilting the top into the inside Head Track channel. Drop the Active Panel onto the Sill Track, then slide the panel into the jamb.

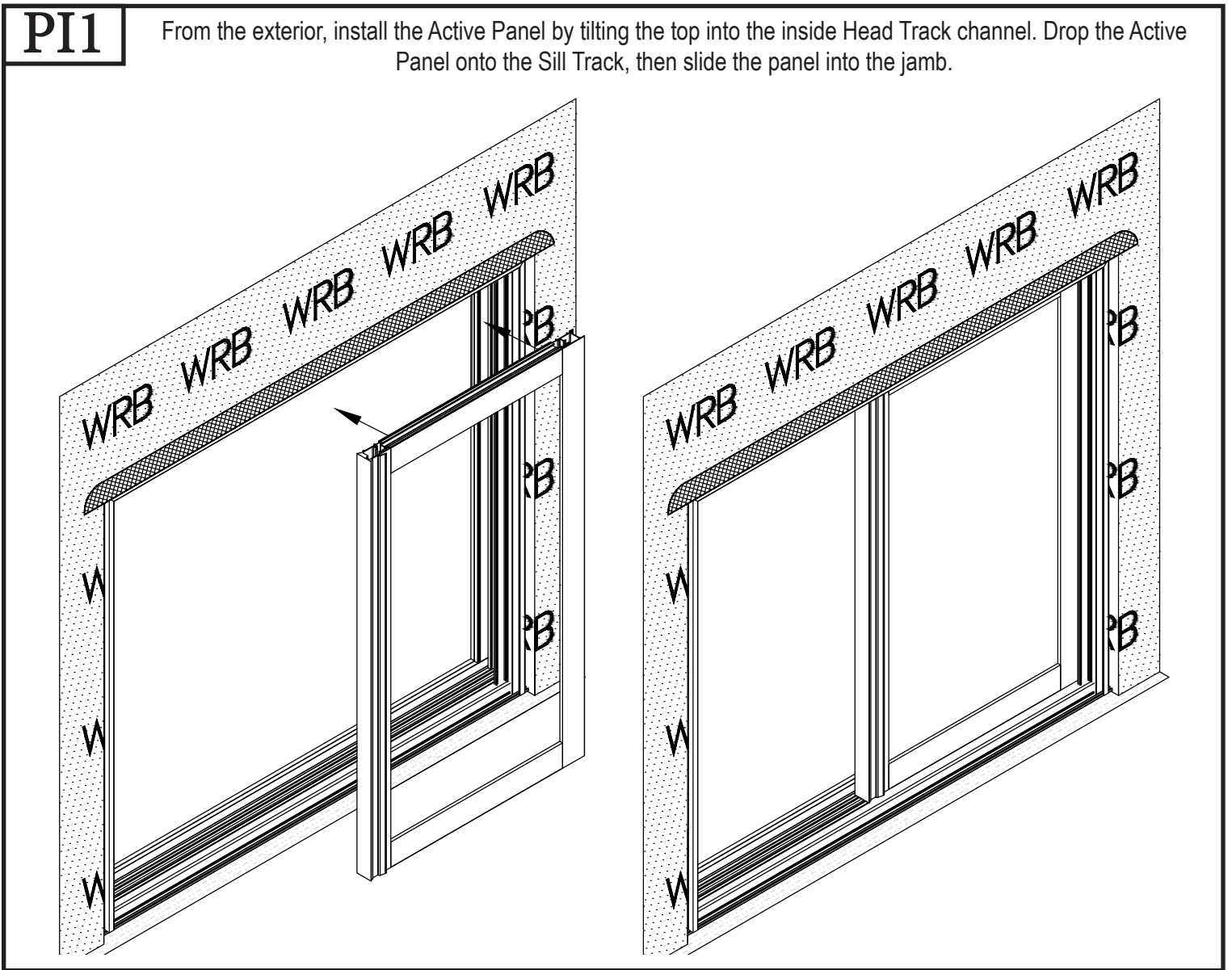

PI2

Insert the Fixed Panel Bracket (M26271-PCS) into the Meeting Stile slot as shown below.
Also, apply the supplied baffles (QWP-688X 15X25) into the Fixed Panel head and jamb.
Remove adhesive backing then apply where shown.

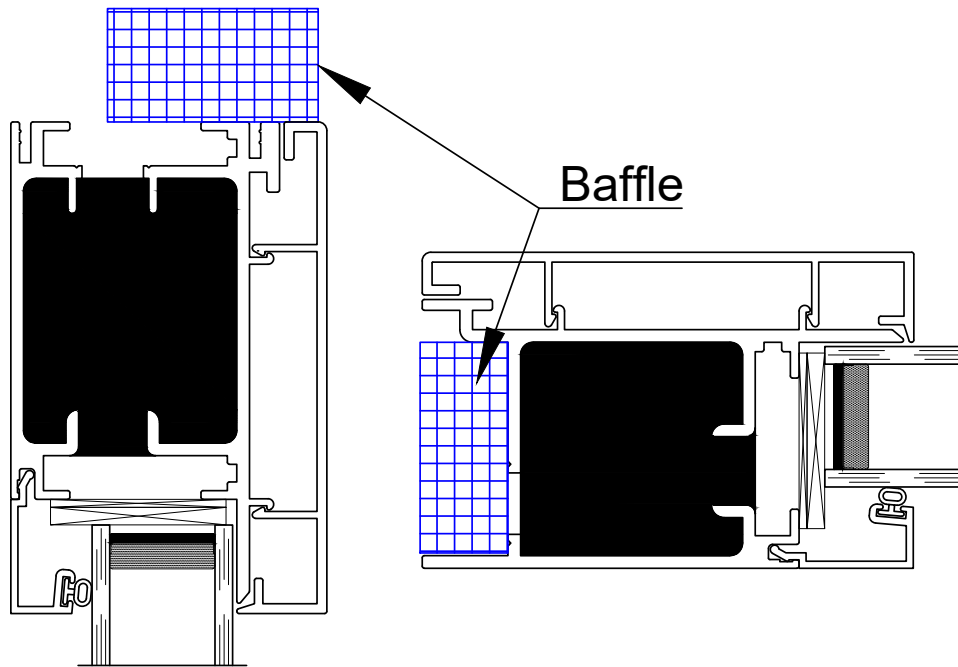
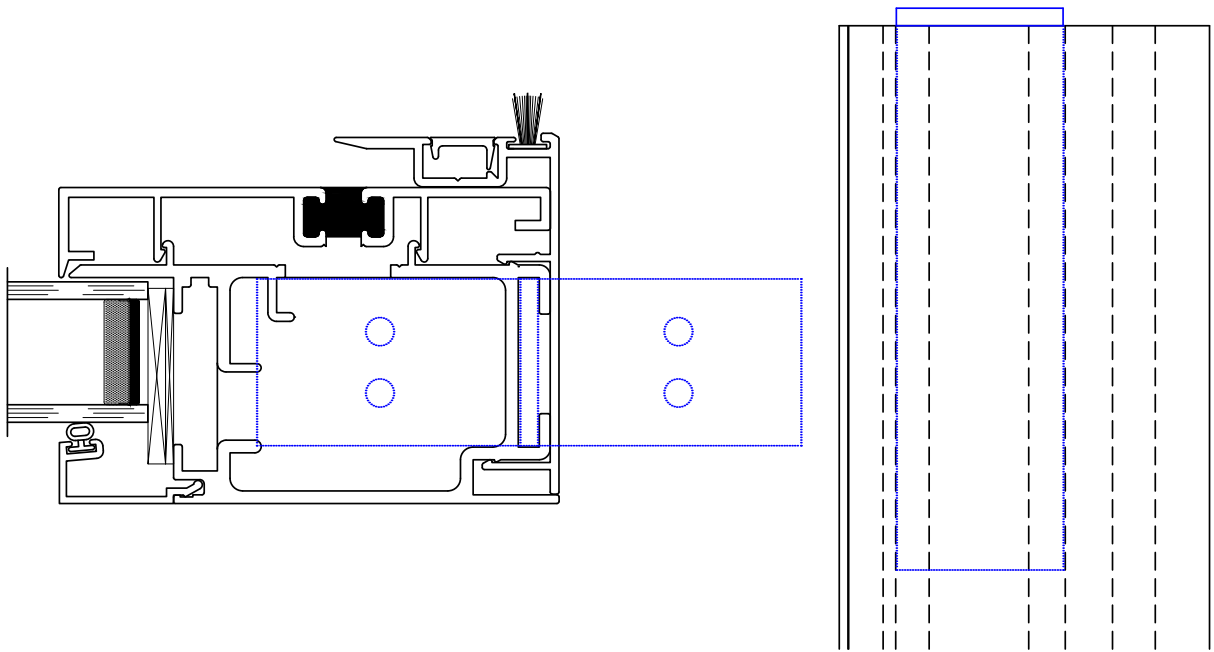

Before installing the Fixed Panel, add sealant as noted below.

From the exterior, install the Fixed Panel by tilting the top into the outside Head Track channel. Drop the Fixed Panel onto the Sill Track, then slide the Fixed Panel with the Setting Chair into to locking lip and slide into Fixed Jamb. After Fixed Panel is in place, add sealant as noted below.

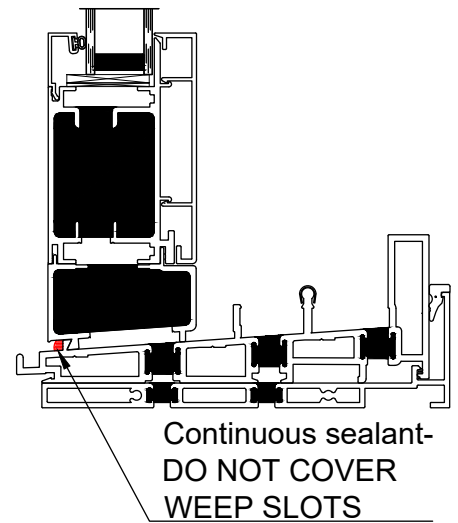
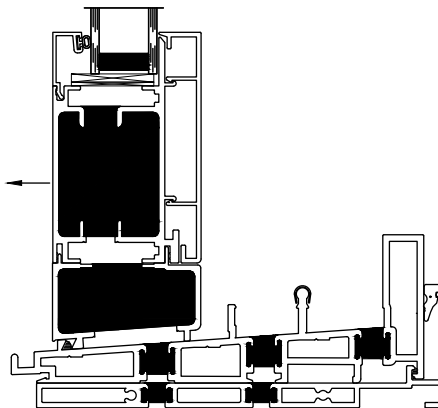
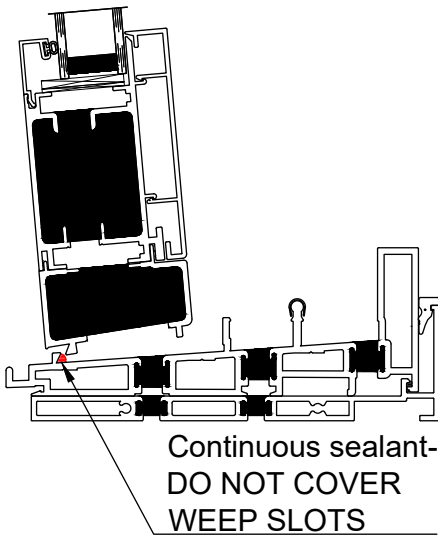
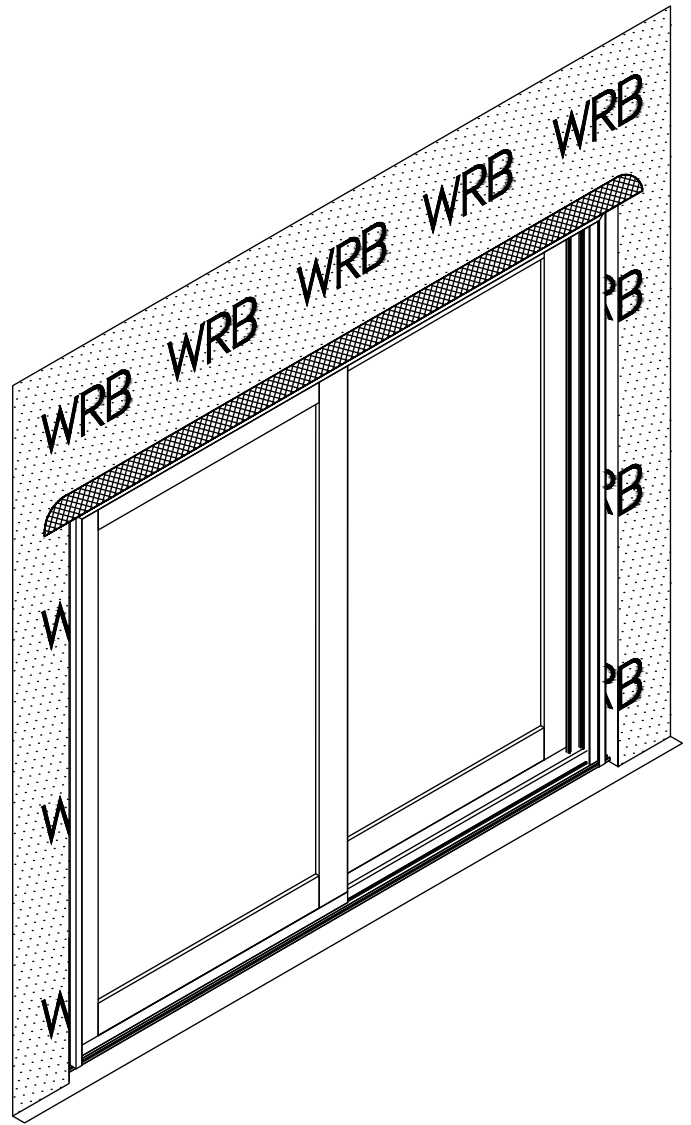
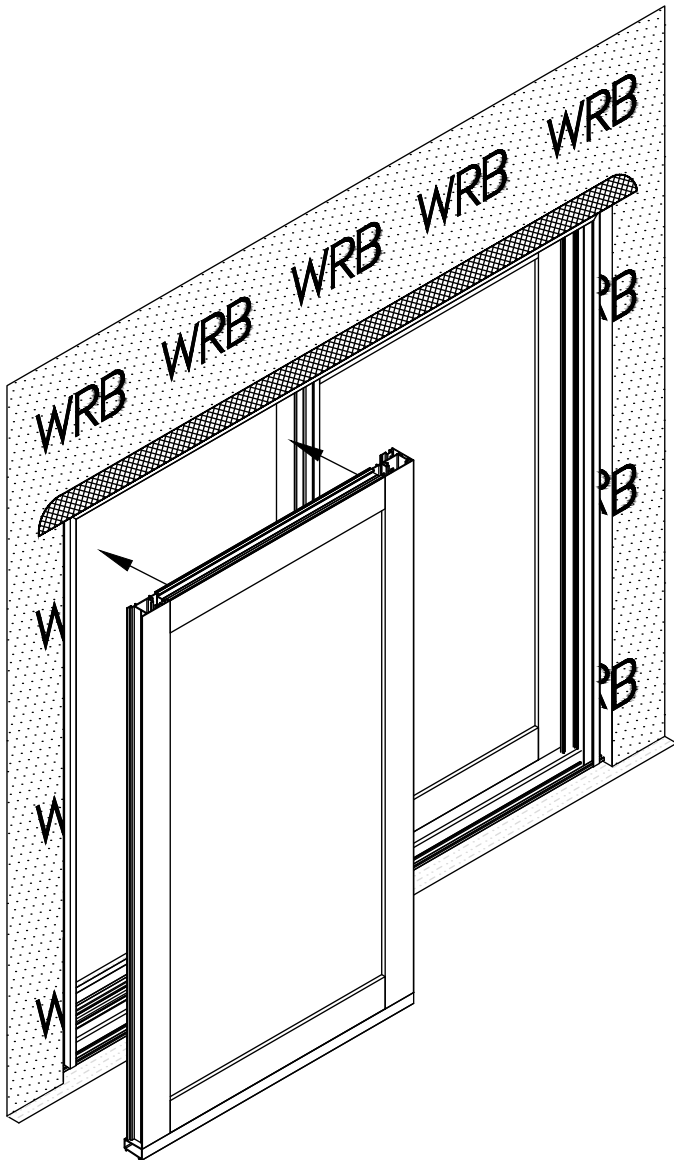

PI4

Insert the Fixed Panel Wedge (BRS-10638 shown -or- BRS-9897 Low Profile).

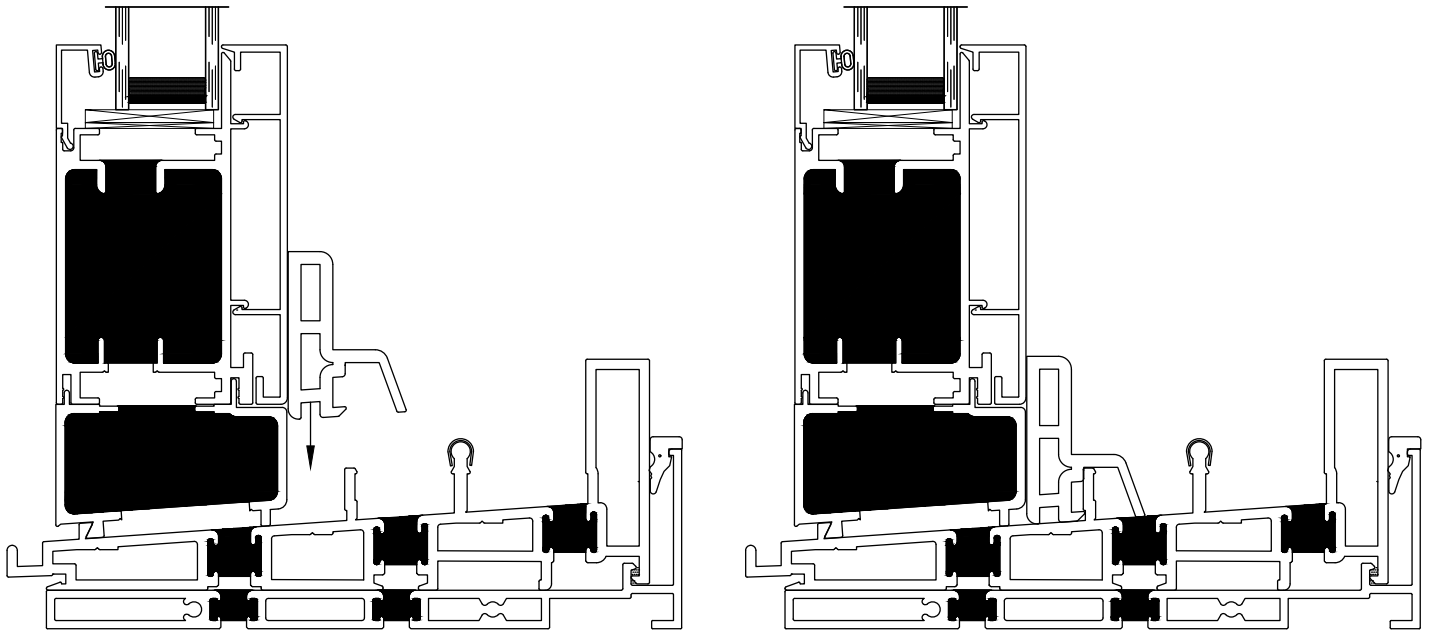

PI5

Slide the panel into the jamb. Locate the panel per the dimensions shown in the figure at right. After the Fixed Panel is in place, screw the Fixed Panel Bracket (M26271-PCS) in place with the supplied fastener as shown below.

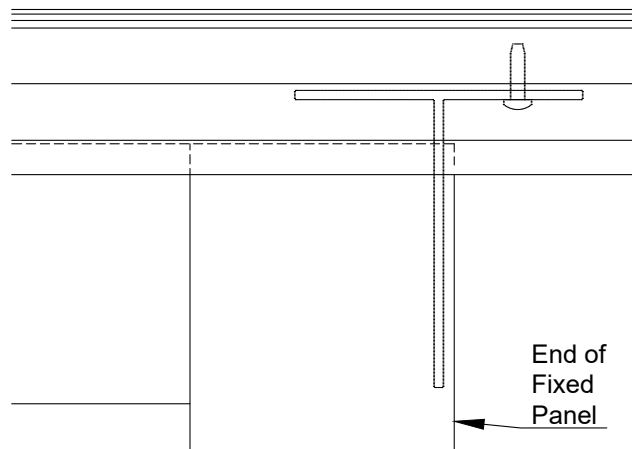
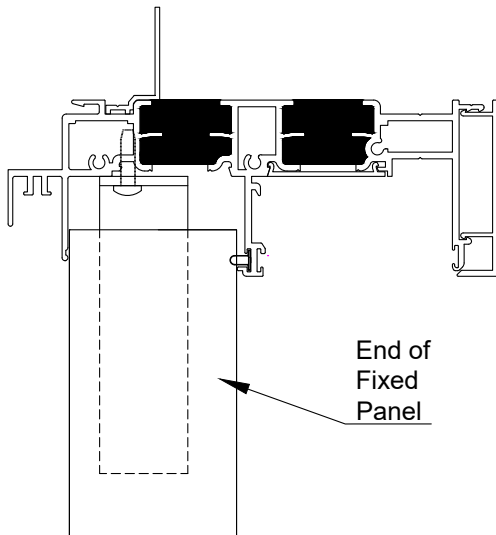
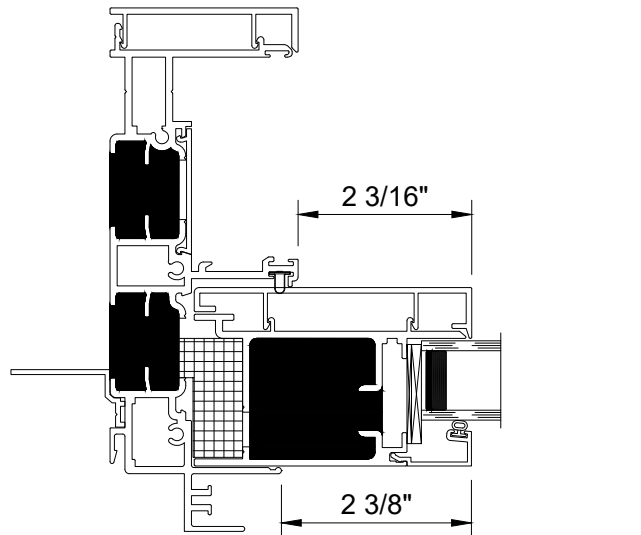

PI6

Seal around the end of the Sill Chair. Tool as needed.
Insert backer rod as needed at the head gap, then seal. Tool as needed.

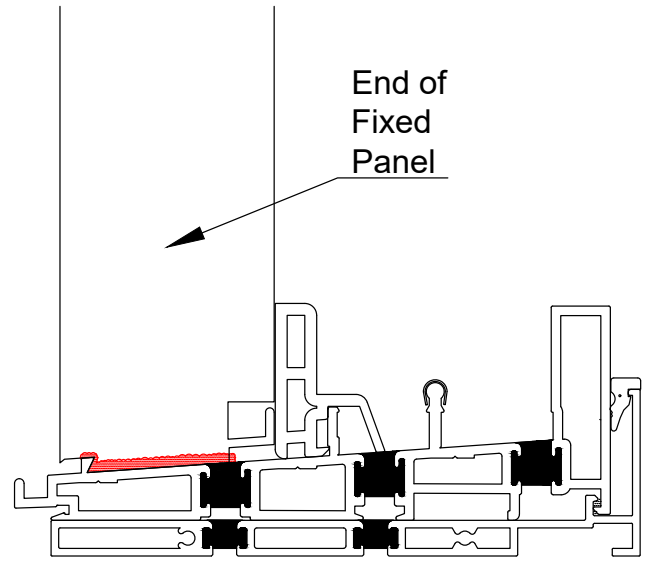
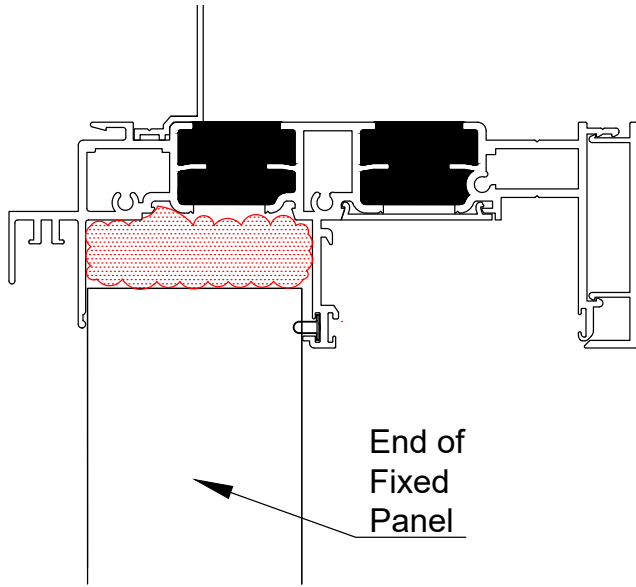

PI7

After installing, use a #2 Phillips Head Screwdriver to engage the roller adjustment on both sides of the active panel. Turn clockwise to raise the panel and provide smooth rolling. If possible, lift the panels slightly when adjusting to take pressure off the rollers. Roll panel back and forth 2 or 3 times to verify roller height is set correctly.

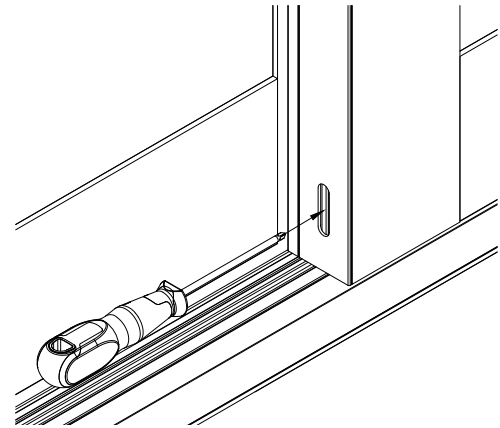

PI8

Once all panels have been adjusted, install the Roller Adjustment Cover (19547-604) into each roller adjustment hole.

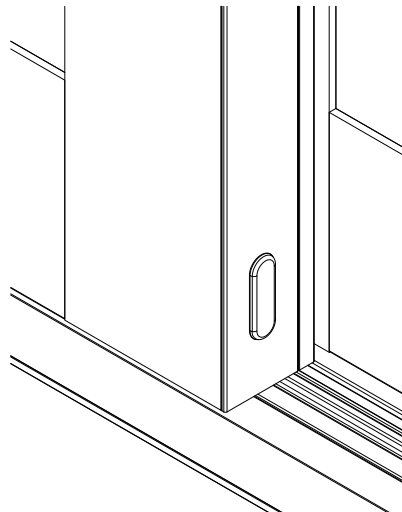
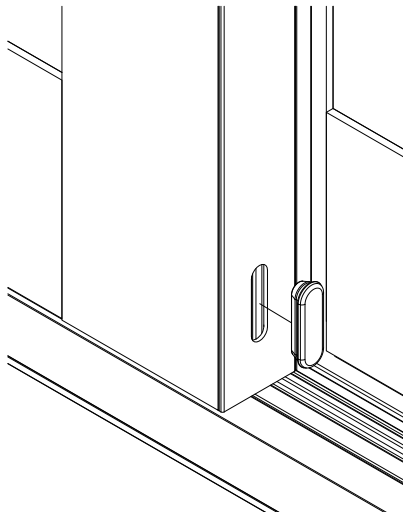

PI9

When using a Bi-Parting Panel application and all Panels are adjusted, Astragals need to be added as shown below (Aluminum part number M26262 -or- Wood part number M26263). The Astragals should be placed on the Panel and cut down if needed. Match drill into the Panel, and attach with the supplied #8-3/4" fasteners.

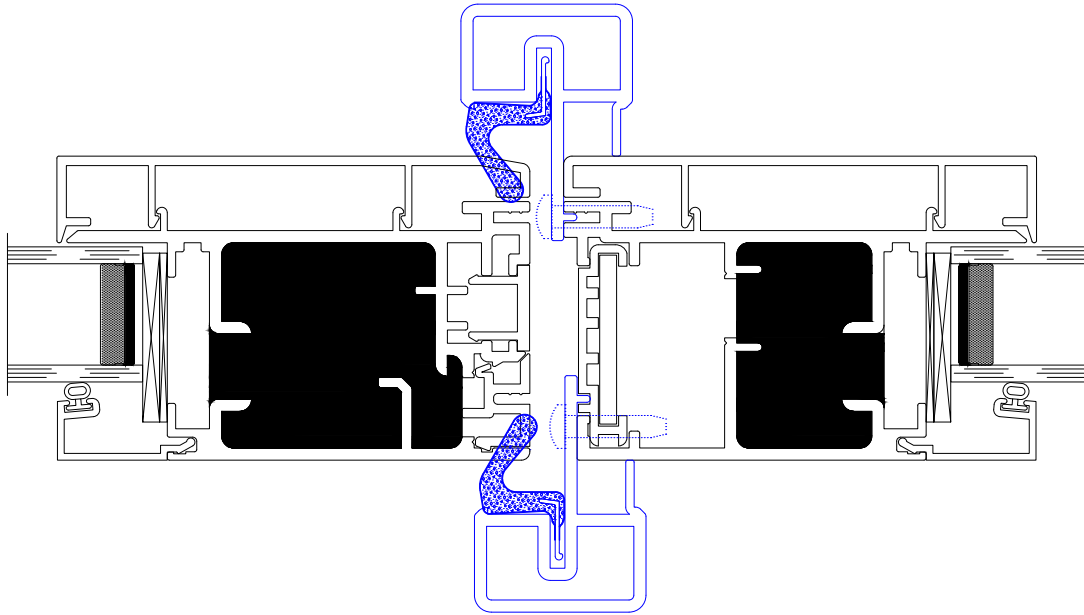

Trim Assembly

TA1

Install the Bumper (BRS-10639 at Standard Sill or BRS-10393-PCS at Low Profile Sill) at the Sill Track, then at the interior Fixed Jamb insert the provided trim as shown below. If a Mallet is needed to engage the trim, use a wood block in between the trim and the mallet.

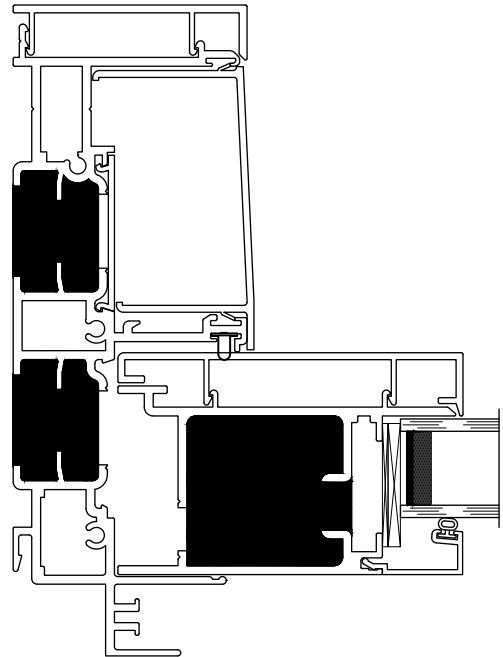
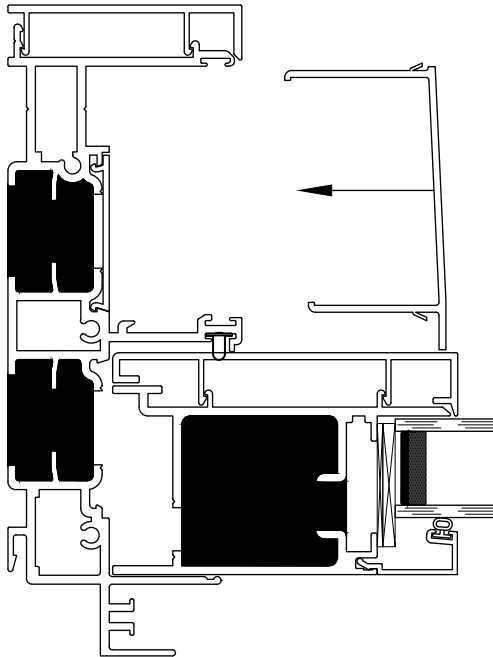
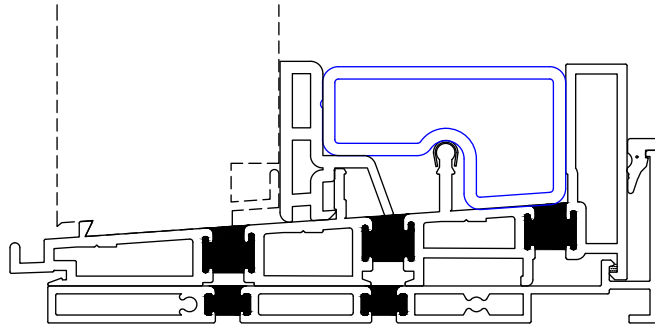

TA2

At the exterior Active Jamb insert the provided trim as shown below.
If a Mallet is needed to engage the trim, use a wood block in between the trim and the mallet.

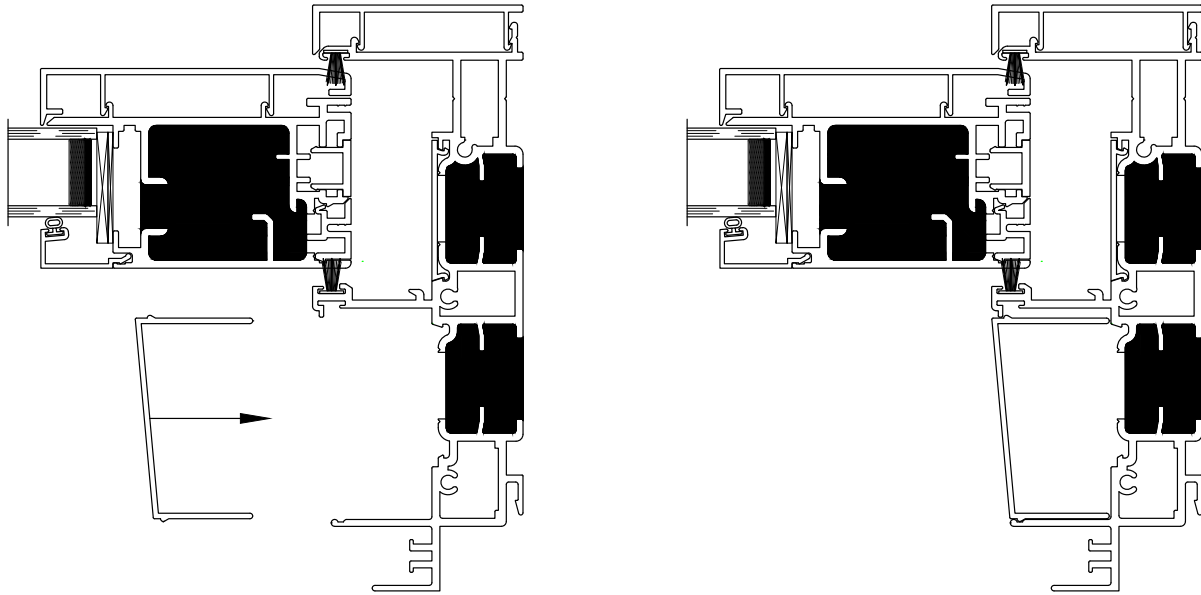

TA3

Roll the active panel away from the jamb. At the exterior Silld insert the provided trim as shown below.
If a Mallet is needed to engage the trim, use a wood block in between the trim and the mallet.

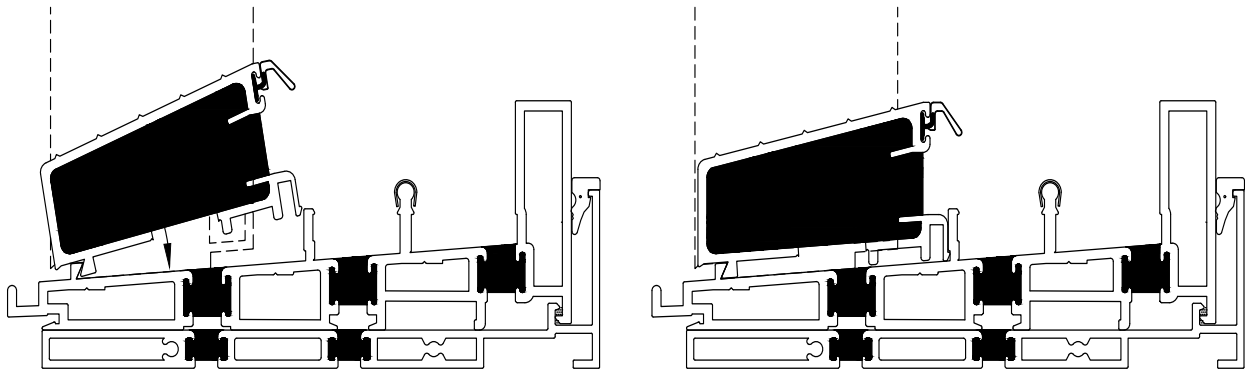

Sealing Instructions

SI1

Insert insulation at the head and jambs where shown below.

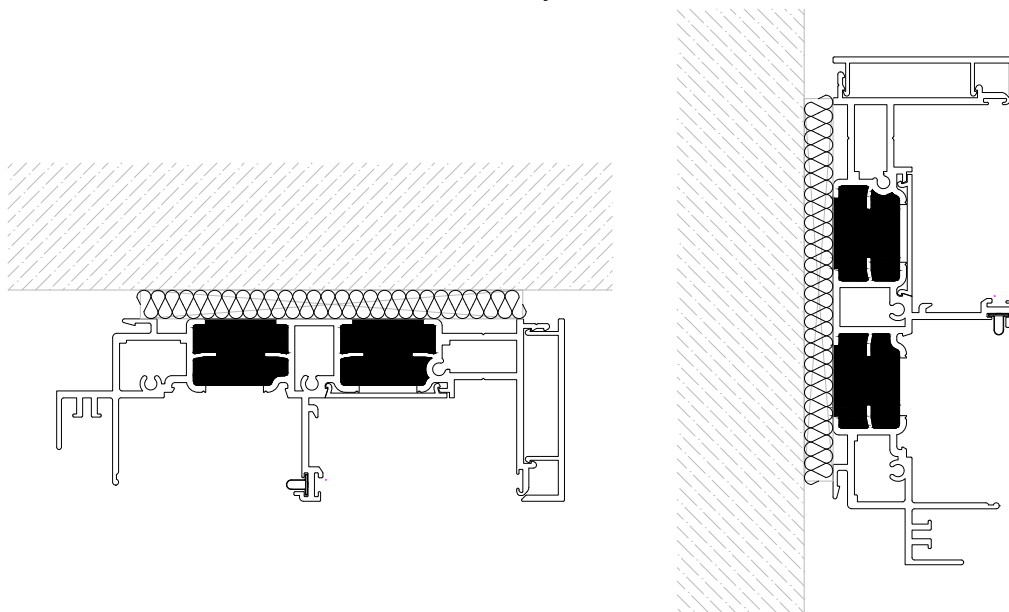

SI2

Refer to the Shop Drawings if additional flashing or other material is required. After exterior building construction is completed, install back rod, then apply a continuous bead of sealant around entire perimeter of window frame and tool in place.

Note:

Installer to verify that Sealant being used is compatible with Quaker window frame and the surrounding building construction materials.

Note:

Please inform the exterior facade installer that they must maintain a minimum 1/4" gap between the facade material and the Window Unit, and that the facade material should never come in contact with the Window Unit.

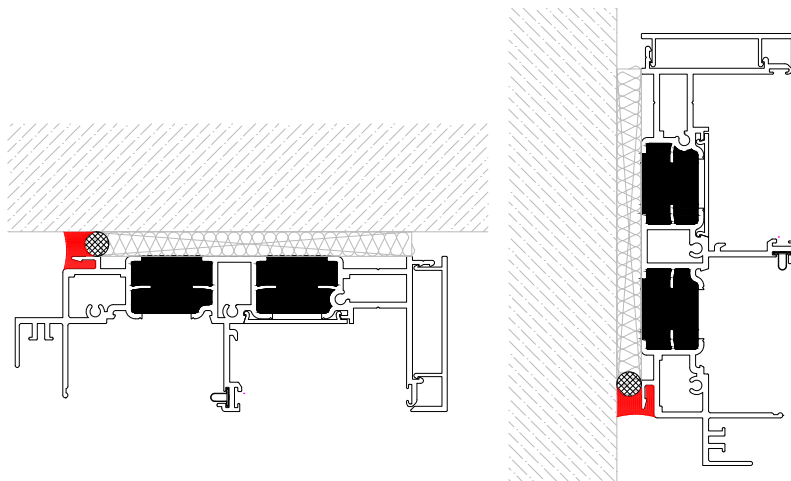
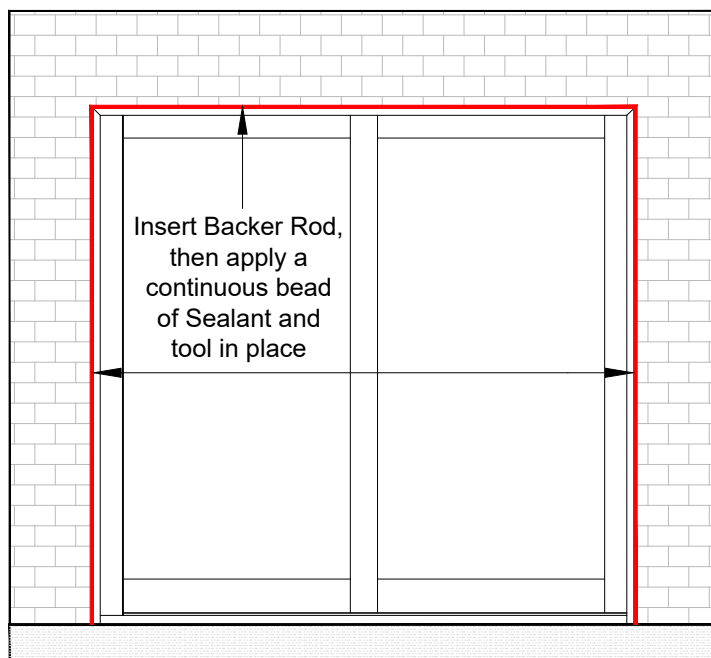

At the interior, install a Backer Rod, then apply a continuous bead of Sealant around the entire perimeter of the frame. Tool sealant in place as needed.

Note:

Installer to verify that Sealant being used is compatible with Quaker window frame and the surrounding building construction materials.

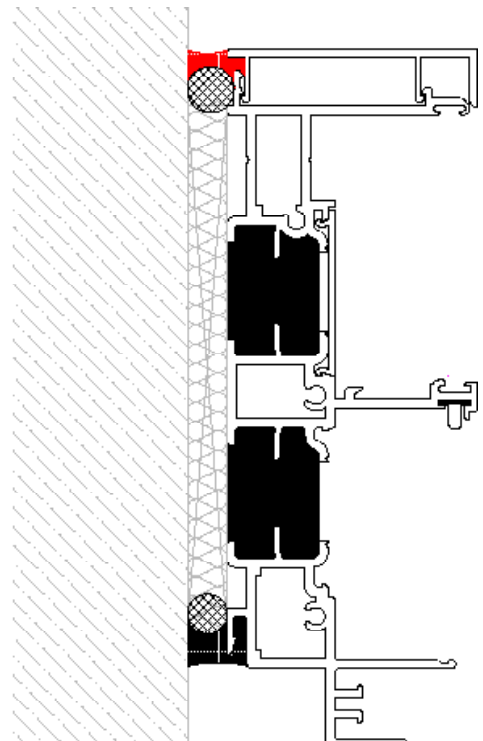
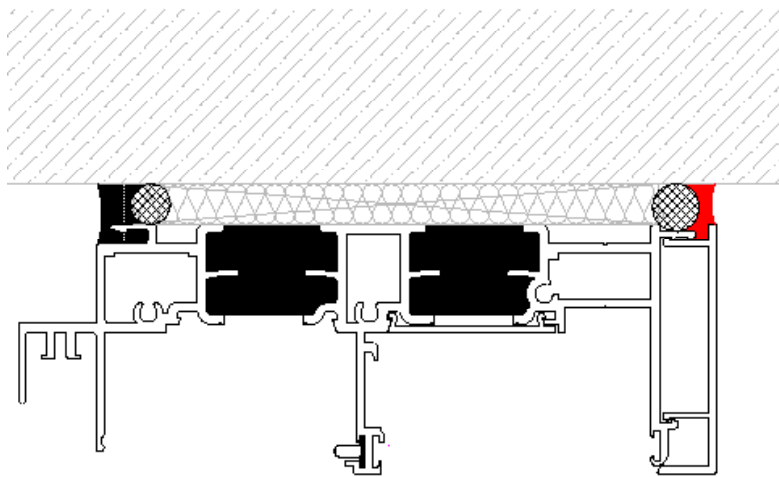
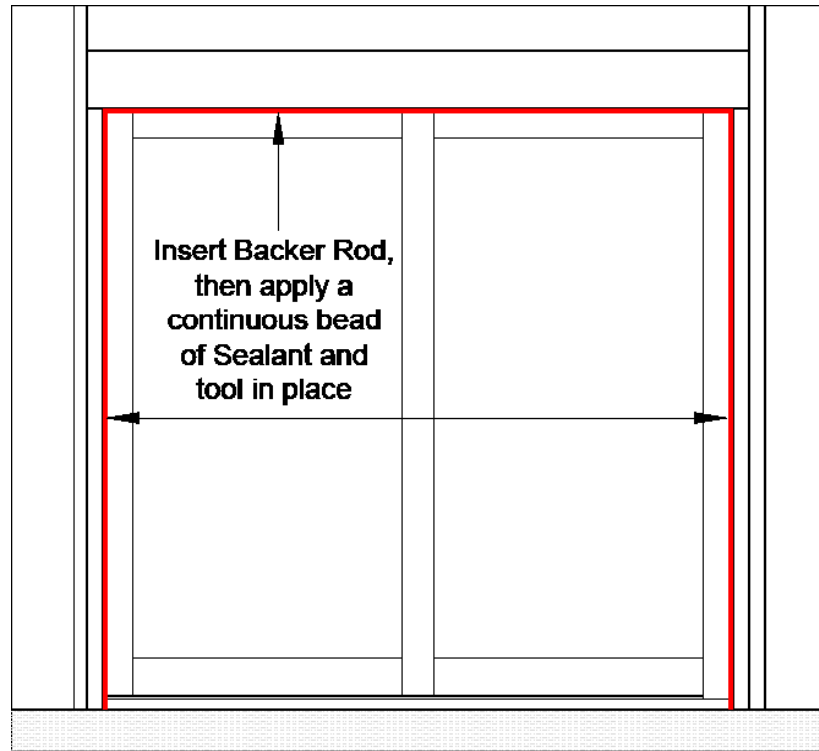

This Completes the Installation