

Head Receptor/Subsill with Square Cut Jamb Receptor for 3 1/4" Deep Systems Installation Guide

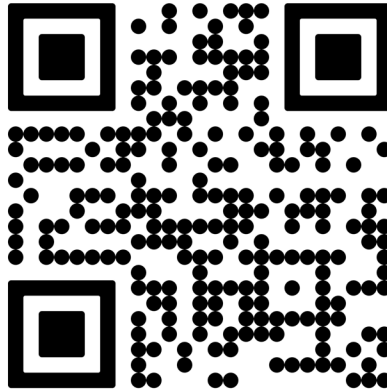

-Scan here for a digital version-

Part # IG-125 - V.1.0 6/22/2026

Pages 5 to 6 -- Weather Resistant Barrier Application (WRB)

Page 20 -- Liquid Barrier Application (LBA)

If this set of instructions does not match your installation method or the wall conditions of the job site, please call Quaker Customer Service for additional information.



Quaker Window Products
504 Highway 63 S
Freeburg, MO 65035
Phone: 800-347-0438
Fax: 573-469-4151
www.quakerwindows.com

Note:

While the details within these instructions are based on the M600 series window, the installation and sealing methods also apply for the other products that measure no deeper in depth than the 3 1/4".

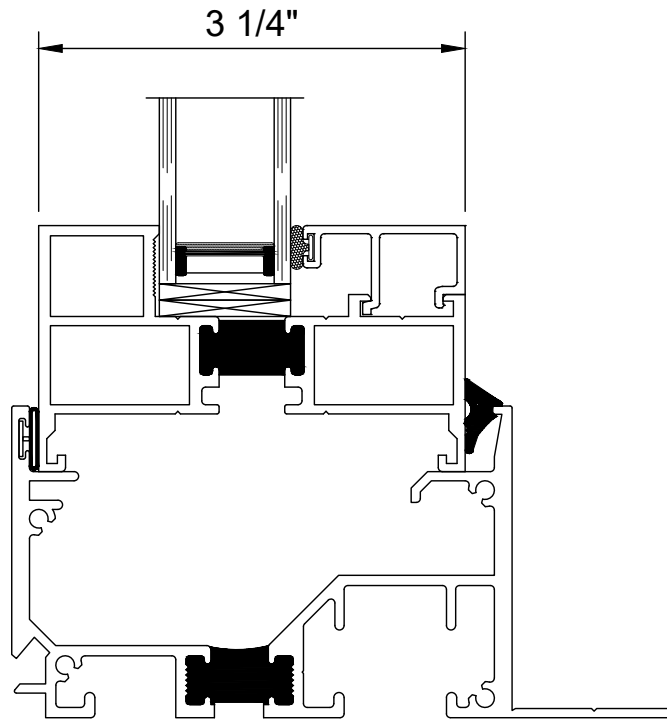

M600/M700

Tools Required by Installer



Materials Required by Installer



-Carefully read these instructions before starting any installation-

Failure to install and maintain QUAKER® products according to these instructions may void any product warranty. However, these are generic instructions that cover common situations and applications, aspects of which may not be appropriate for all installations due to building design, site conditions, construction materials, or installation methods used. Refer to shop drawings, if applicable, for additional notes and details. Please consult Quaker for specific applications not covered in these installation instructions, or visit our website at www.quakerwindows.com, or call 800-347-0438 for additional information.

Tools

- Follow manufacturer's instructions and safely operate tools, ladders, or scaffolding. Always wear safety glasses. Failure to do so could result in injury, product, or property damage.

Handling

- Do not store QUAKER products outside or in an unprotected, high moisture, or high heat environment prior to installation. Doing so could result in product damage.
- Do not carry, transport, or store QUAKER products in a flat (horizontal) position. Doing so could result in product damage or injury.
- Window and door units should be kept or stored in an upright (vertical) position, with support across the sill to avoid bowing. Do not lay any units in a flat position!

Glass

- If glass gets broken, please exercise caution, as glass fragments can cause lacerations or other injuries. In many areas, local building codes require safety glass to be used in certain applications. All QUAKER products are available with safety glass if they are ordered that way.

Fastening

- Metal fasteners and components could corrode when used in contact with preservative-treated lumber. Use approved and appropriate fasteners and components to fasten QUAKER products in this application. Failure to do so could result in a product performance failure, injury, or property damage.
- Quaker does not provide anchorage or fastener calculations.
- Quaker is not responsible for determining structural adequacy of the anchorage and fasteners used to install QUAKER products, or the openings into which they are installed.

Installation

- Report any damage to dealer immediately. Do not install product if damaged. Quaker is not responsible for addressing products that are damaged after delivery, or product that is installed in a damaged condition.
- Always support window or door products in an opening until fully fastened. Failure to do so could result in the product falling out of an opening and causing injury, product, or property damage.
- Nailing flanges and drip caps (integral or applied) do not take the place of window flashing. All QUAKER products must be properly flashed and sealed with material compatible sealant for protection against water and air infiltration around the entire exterior perimeter. Failure to do so could result in a product installation failure and property damage.
- Windows and doors must be properly shimmed. To properly shim a QUAKER product, follow relevant installation guidelines, and never set a window directly on a sill plate. Failure to shim properly is an installation failure that could result in product performance failure or property damage.
- Construction directly above an opening must be engineered and designed not to transfer loads directly to any windows or doors. If live or dead loads are transferred to a QUAKER product, this may affect functionality and result in glass failure or otherwise damage frame joinery, perimeter seals, or other aspects of the product. Proper construction of the rough opening must take place prior to the installation of the QUAKER product.
- Please confirm that any necessary vertical deflection of the head condition is consistent with the selected QUAKER product. Most QUAKER products are not designed to allow any deflection at the head condition. Shop drawings may indicate the maximum allowable vertical deflection at the head condition of a QUAKER product. If vertical deflection is a concern but shop drawings are not provided, please contact Quaker for assistance.
- Windows and doors have small parts that, if swallowed, could pose a choking hazard to young children. Please dispose of unused, loose, or easily removed small parts. Failure to do so could result in injury or death.
- Do not drill through or into the sill or frame of any QUAKER products, whether to install alarm wires or for any other reason.
- During installation and positioning of any window or door products with an aluminum frame, make sure to align the thermal break of the product, with the insulation plane or air barrier of the building itself, in order to maintain continuity and integrity of the thermal envelope, and prevent thermal bridging that leads to excessive thermal transfer and/or condensation. In other words, the thermal break of the product must be recessed from the exterior plane of the wall opening, remain fully embedded within the wall opening, and not be exposed directly to exterior elements.

Sealing

- Follow supplier instructions for proper application of minimally expanding foam, sealant, water resistant barrier or liquid barrier, and flashing products and systems to ensure safety, proper material application, compatibility, and to understand the need for periodic maintenance for continued weather resistance of their products. Failure to do so could result in product performance failure or property damage.
- Minimally expanding foam insulation must be compliant with AAMA 812.
- If silicone is selected as an appropriate sealant, Quaker recommends using 100% neutral cure silicone sealant, that is ASTM C920 compliant. Always clean and prepare the surfaces where the sealant will be applied per the manufacturer's recommendation. Once applied, properly tool the sealant in place. Failure to do so could result in product performance failure or property damage.
- Flashing tape must meet ASTM-D779 performance requirements.
- Maintain and properly seal a minimum of 1/4" gap (or whatever is specified within these installation instructions or shop drawings) around the perimeter of the window or door frame and the exterior finish materials. Failure to do so could result in product installation failure or property damage.

Joining

- Do not join any Quaker product to another product that is not designed for joining. Joined products must be individually supported in the opening. Failure to do so could affect operation and product performance and could result in a product installation failure or property damage.

Cleaning

- Do not use any cleaning agent other than a mild, non-abrasive window washing solution or glass cleaner applied in accordance with any product labeling instructions and Quaker's care and maintenance instructions. The use of harsh chemicals (such as brickwash, bleach, alcohol, hydrochloric acid, or muriatic acid) for cleaning or other purposes may damage QUAKER products, glass, fasteners, hardware, seals, sealant, or metal flashing. Please protect these products by following the cleaning product's instructions for its proper use.
- Do not use a razor blade to clean a glass surface, as damage to the glass may result.

IMPORTANT

- Buildings constructed prior to 1978 may contain lead paint which could be disturbed during window or door replacement. For more information on proper management of lead paint, go to: www.epa.gov/lead
- Care must be taken to properly recycle or dispose of used or old materials. Any recyclable material should be separated from non-recyclable or hazardous materials. Please consult with local or state authorities regarding proper disposal of non-recyclable or hazardous materials.
- Inspect all window and door units for any damage or defects prior to installation. Contact the nearest QUAKER distributor if there are any problems or issues.
- **WARNING:** This product can expose you to chemicals, including titanium dioxide or methanol, which are known to the State of California to cause cancer and birth defects or other reproductive harm. For more information go to www.P65Warnings.ca.gov
- **WARNING:** Drilling, sawing, sanding, or machining wood products can expose you to wood dust, a substance known to the State of California to cause cancer. Avoid inhaling wood dust or use a dust mask or other safeguards for your personal protection. For more information go to www.P65Warnings.ca.gov
- When installation is completed, operable window and door products, and related hardware or equipment, may require some adjustments. Confirming operability and making minor adjustments are within the scope of the installation services performed by others.
- **WARNING - OVERHANG NEEDED:** It is recommended that doors (swing and sliding) with ADA or Low-Profile Sills be installed with an overhang depth equal in length to the height of the door. If you choose to use an overhang depth less than the height of the door, you must confirm that it is appropriate based on code requirements and the expected local wind and rain conditions.

WB1

From the interior, measure and verify the size of the rough opening. The rough opening should be $\frac{3}{4}$ " wider and $\frac{3}{4}$ " taller than the Receptor Unit, unless otherwise specified on the shop drawings. Verify the rough opening is flat, plumb, level, and square. Take diagonal measurements to check for square.

The sill plate beneath the unit must be level for proper unit operation.

Go to the exterior and cut the Weather-Resistant Barrier (WRB) in an 'I' pattern.

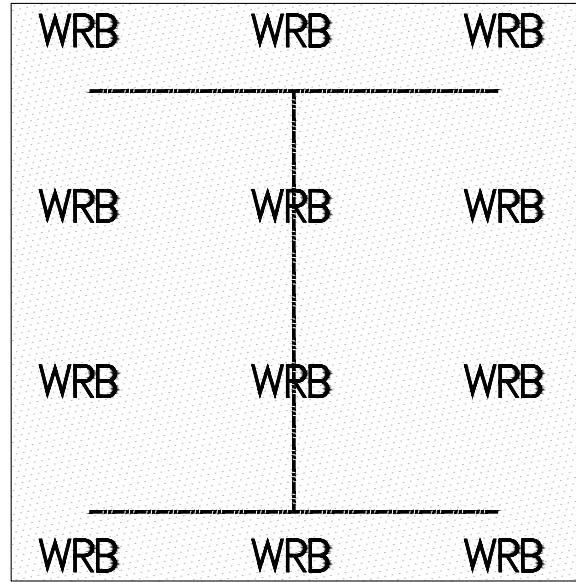
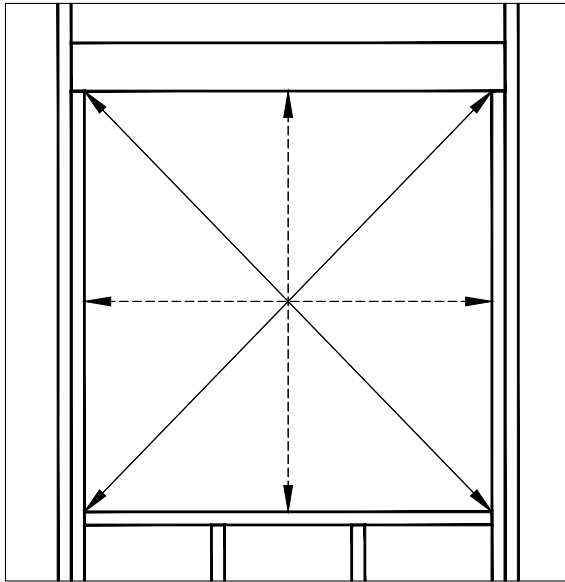

WB2

Fold the WRB sides towards the interior and trim as needed. Do not staple in place. Make 4"-6" horizontal cuts in the WRB at the head and sill jambs. Fold back WRB at the cut lines, and tape into place.

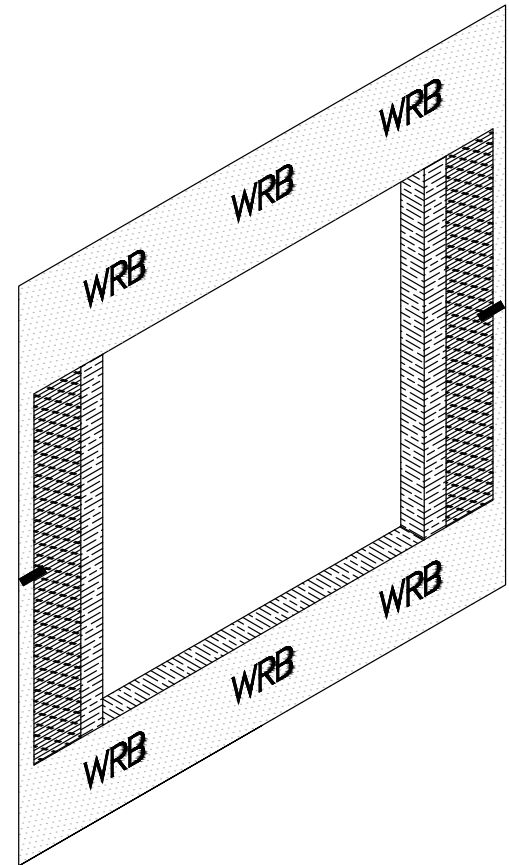
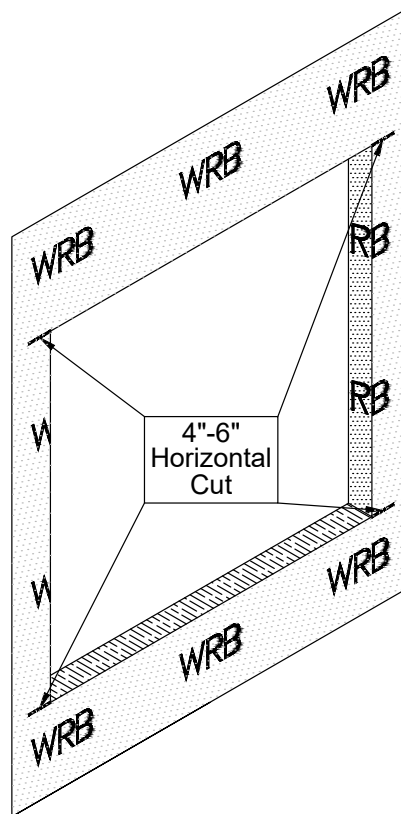
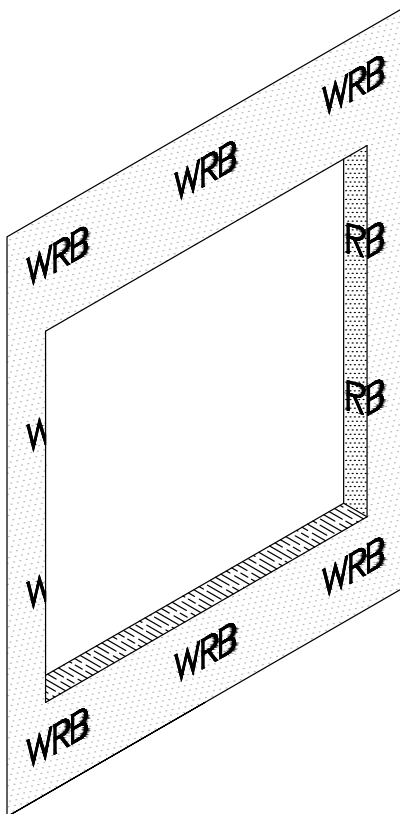

WB3

Measure the width of the rough opening, and cut two (2) lengths of self-adhering flashing that is 12", or more, than the width of the rough opening. This will allow the flashing to run 6"+ up/down each jamb condition. Apply the flashing to the exterior sill side first, allowing for a minimum of 3" below the sill and up each side. The flashing tape must cover the entire sill plate. Then apply the flashing to the exterior head side first, allowing for a minimum of 3" above the head and down each side. The flashing tape must cover the entire head member. If needed, apply an additional piece of flashing over the first one with a 1" minimum over-lap. Start from the exterior and work towards the interior. After applying the sill/head flashing, apply sealant at the jambs where shown. Fold the WRB jamb flaps back into place, over the sill flashing, and fix into place.

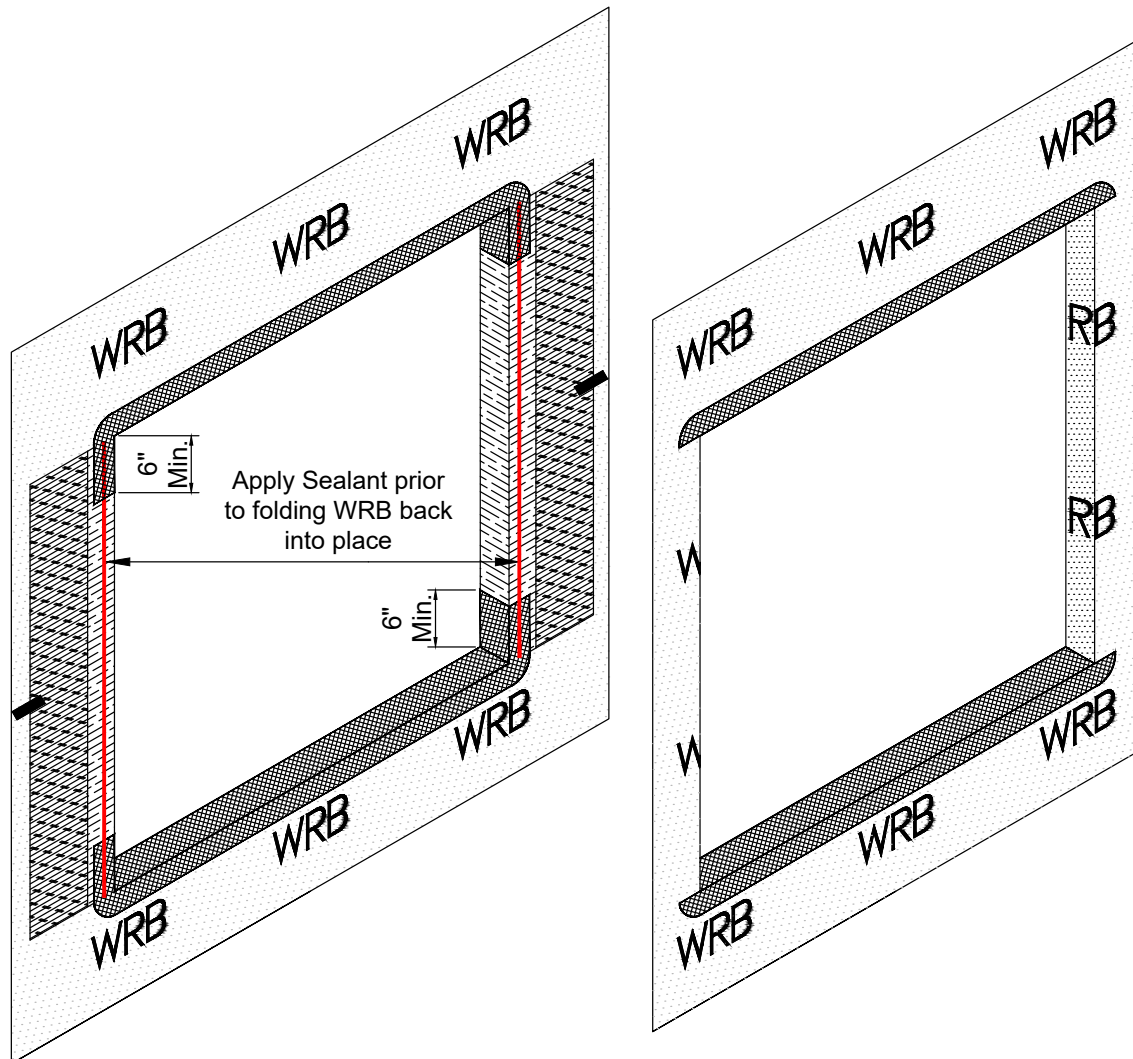

WB4

Before starting assembly and installation, the weathering in the exterior receptors must be cut back.

In most cases this weathering is longer than the receptors.

At the Head and Sill Receptors, the weathering should be cut back 1 1/2" from end of the part at each end.

At the Jamb Receptors, the weathering should be cut back to part length.

The interior weatherings should be cut to part length, unless noted otherwise.

FI1

Apply sealant to the entire end of the Sill and Head members where shown. Attach the End Dam with the supplied screws (MPT8Ax1/2), and tool sealant if needed. Repeat these steps on the other end.

Go to steps FI5 and FI6 if a splice is required.

When a T-Mullion is required, go to step FI8.

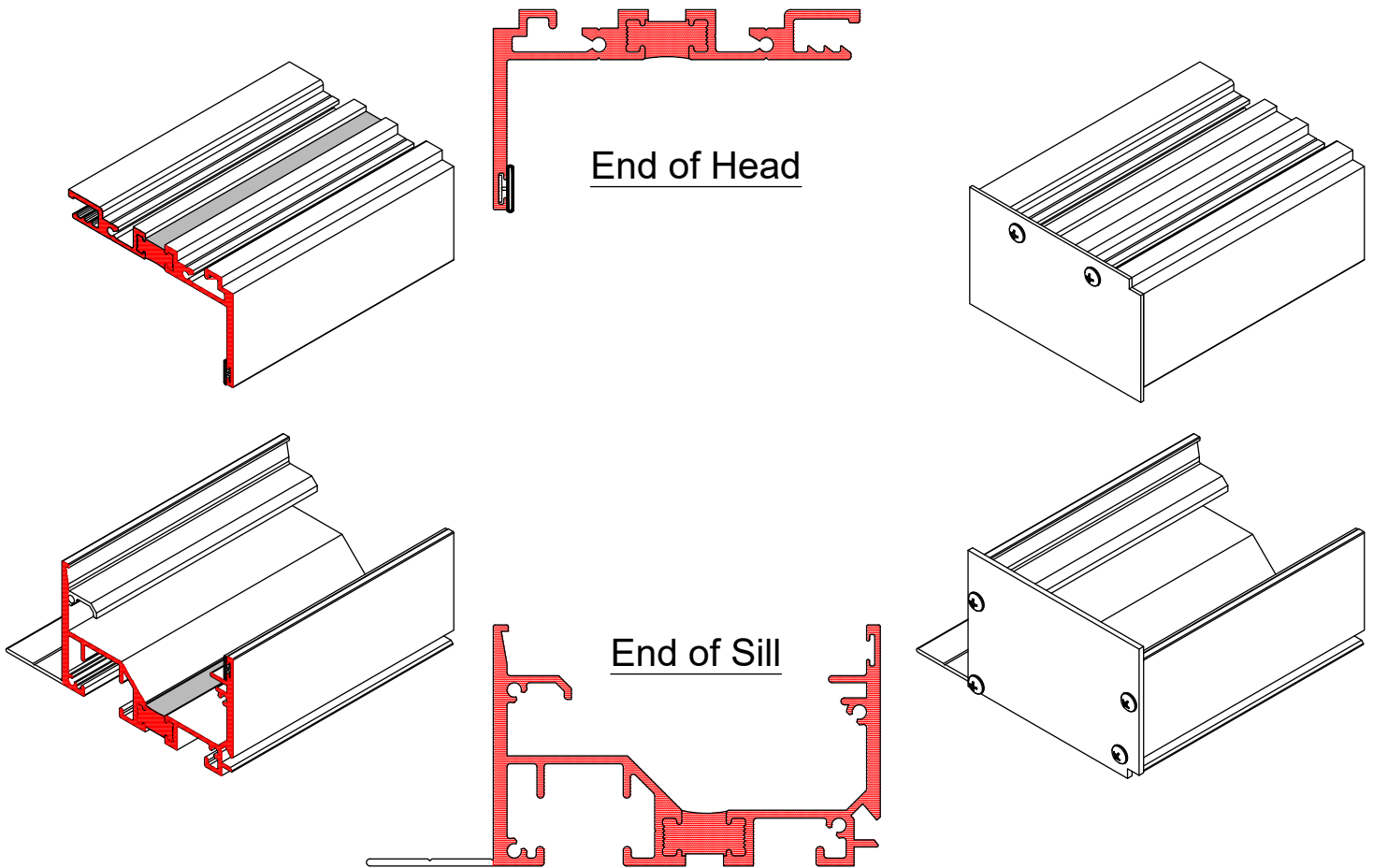

FI2

If not already done, drill holes into the perimeter of the Head Receptor as called out on the Shop Drawings or the Structural Calculations.

Install the Head Receptor into the opening. Use plastic shims to ensure it is plumb and level (**DO NOT PLACE RECEPTOR UNIT DIRECTLY ON THE BUILDING STRUCTURE WITHOUT SHIMS**).

When level, drill pilot holes in the surrounding conditions and fill with sealant. Check again to make sure the Head Receptor is plumb and level and anchor into place with the appropriate fasteners.

If a splice is required, leave a 1/4" gap between the frames (See FI5 and FI6 for Splice instructions)

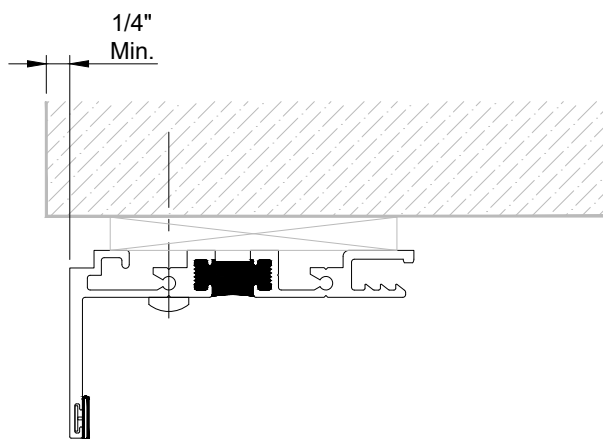

Fastener locations are for reference only. Locations should be located where shown on the Shop Drawings or the Structural Calculations, and should be inserted into a structural part of the surrounding conditions.

FI3

If not already done, drill holes into the perimeter of the Sill Receptor as called out on the Shop Drawings or the Structural Calculations. Install the Sill Receptor into the opening making sure to align the face with the Head Receptor Face. Measure distance between the bottom of the Head Receptor to the top of the Sill Receptor. If Jamb members are shipped already sized, verify this distance does not exceed the Jamb being used. If necessary, shim as needed to reduce the distance to equal the Jamb length. Jamb members can be field cut to fit in the field if needed. Use plastic shims to ensure it is plumb and level.

(DO NOT PLACE RECEPTOR UNIT DIRECTLY ON THE BUILDING STRUCTURE WITHOUT SHIMS).

When level, drill pilot holes in the surrounding conditions and fill with sealant. Check again to make sure the Head Receptor is plumb and level and anchor into place with the appropriate fasteners.

If a splice is required, leave a 1/4" gap between the frames (See FI5 and FI6 for Splice instructions)

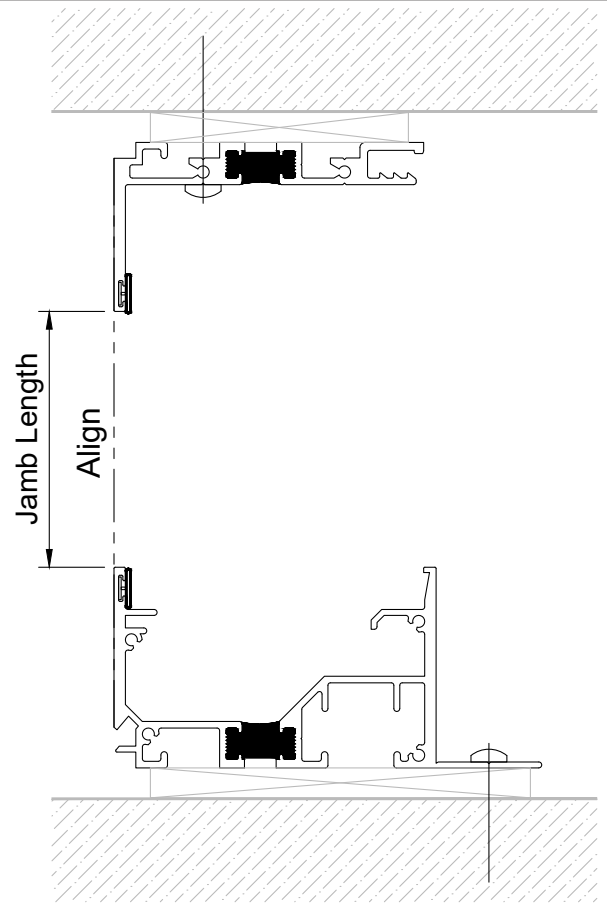

FI4

After Receptor Unit is fully installed, seal the End Dam-to-Sill and End Dam-to-Head joints. Tool sealant to assure the joint is sealed completely.

NOTE:

This step can be done prior to the Sill and Head being installed. If done prior to installation, please verify the seals are still intact after the Sill and Head are in place. Re-seal if needed.

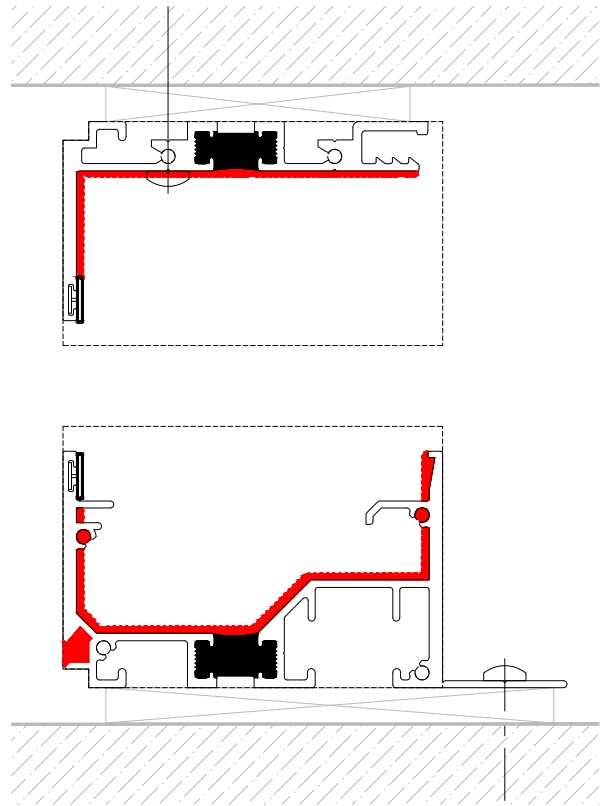
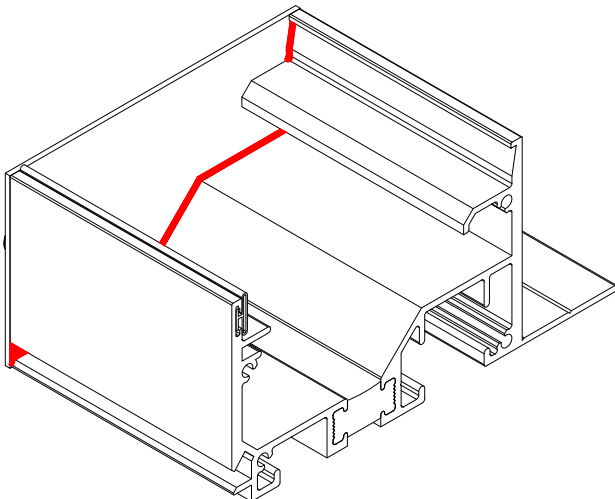

FI5

When a splice is required, make sure there is a 1/4" gap between the Receptor Units.
Cut (2) Dowsill-123 (or equivalent) Splice Sheet to size, approximately 5 1/4" long and 4" wide for the Sill and 4 1/2" long and 4" wide for the Head. Apply silicone sealant to the ends of both Sills (sealant not required at the Head), and set the Sill Splice Sheet in place. After the Splice Sheet is pressed into place, apply silicone sealant to the edges of the Splice Sheet and tool as needed.
Now set the Head Splice Sheet in place and apply silicone sealant to the edges of the Splice Sheet and tool as needed.

-DO NOT LOCATE SPLICE AT T-MULLION LOCATION-

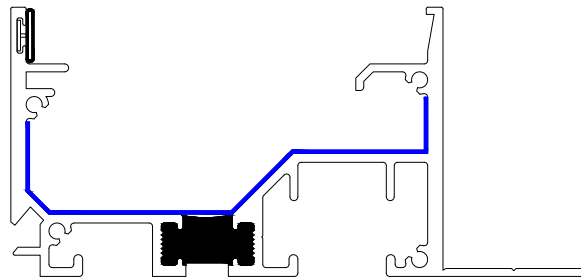
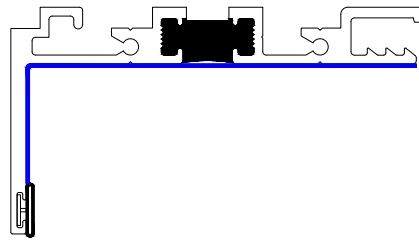
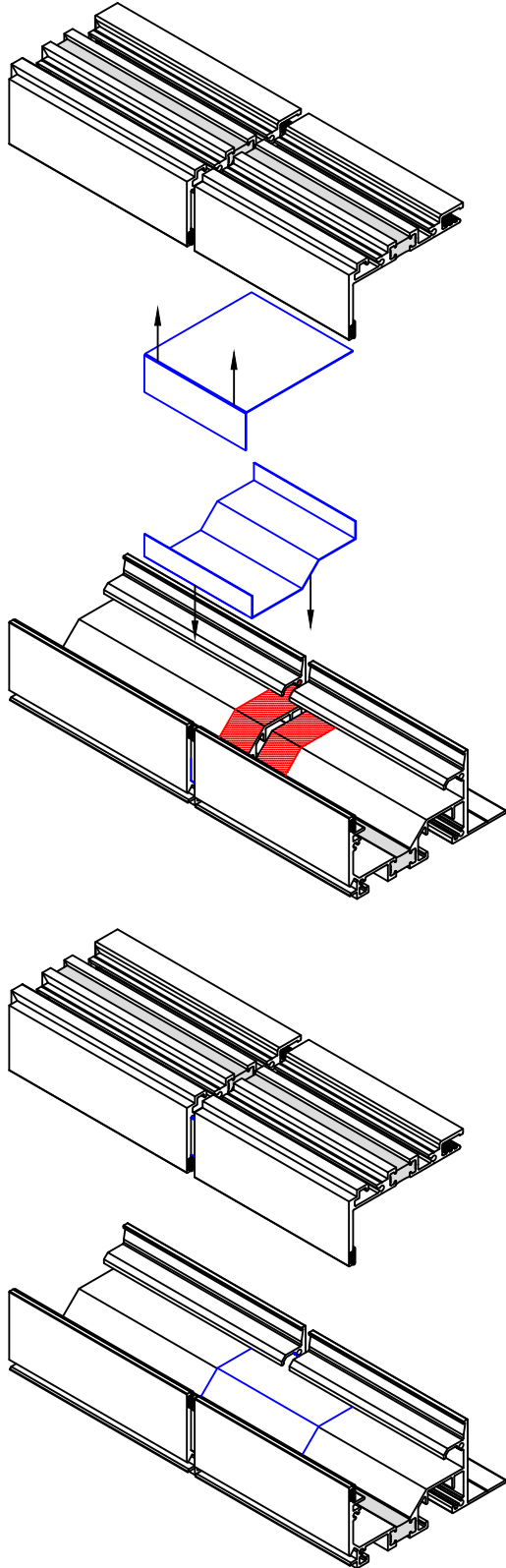

FI6

After the Splice Sheets are in place, push backer rods into the splice joints as shown below. Then apply sealant to all exposed exterior Head and Sill Receptor joints, and at the interior Sill Receptor joint. Tool sealant as needed.

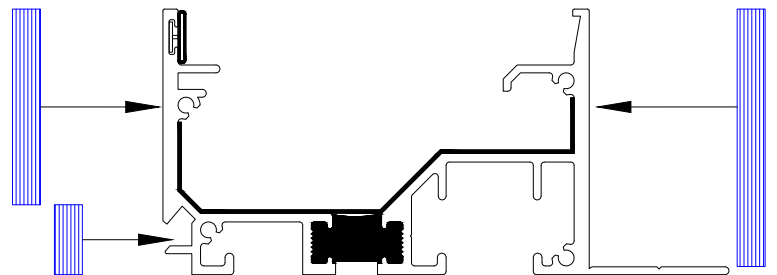
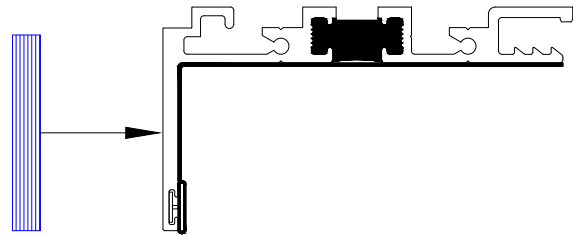
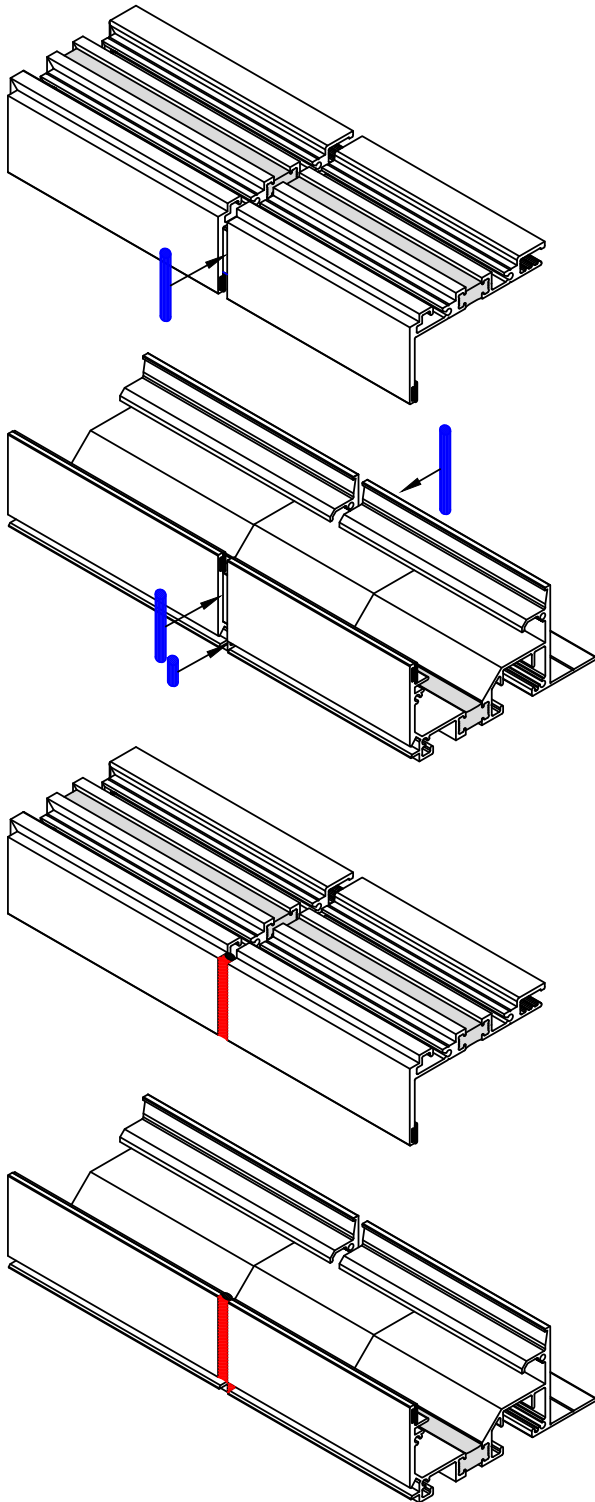

FI7

Before proceeding, verify that all of the Weep Baffles are in place. If not, Weep Baffles must be installed. Pull the backing off and center at the weep slots.

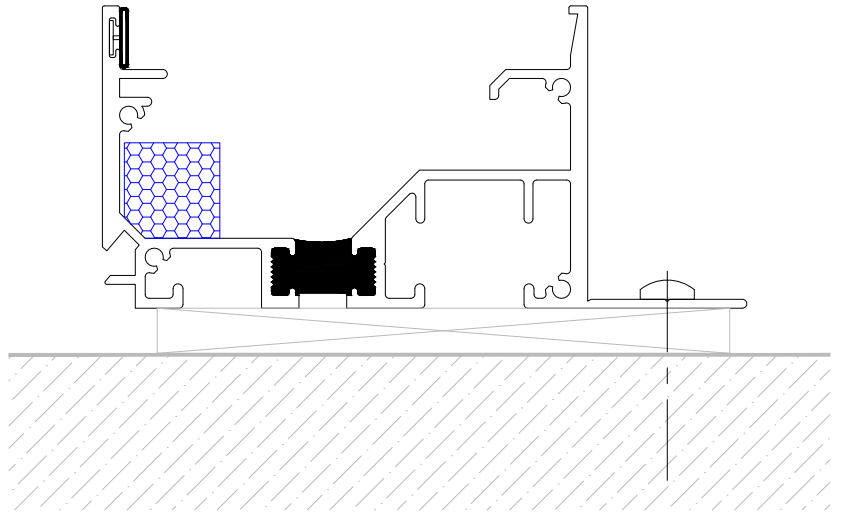

FI8

When a T-Mullion is required, locate the supplied Anchor Plate where indicated on the Shop Drawings. The centerline of the Anchor Plate should align with the centerline of the T-Mullion.

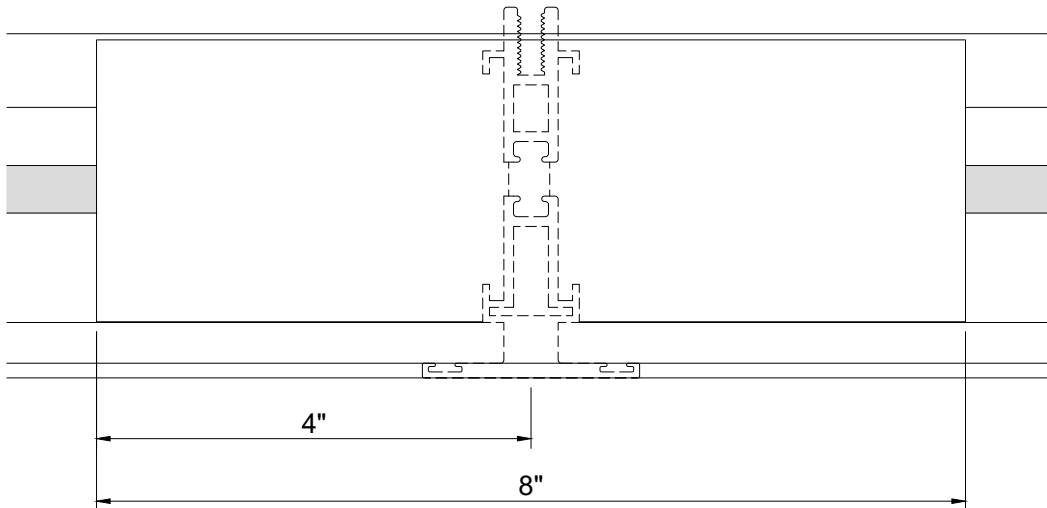
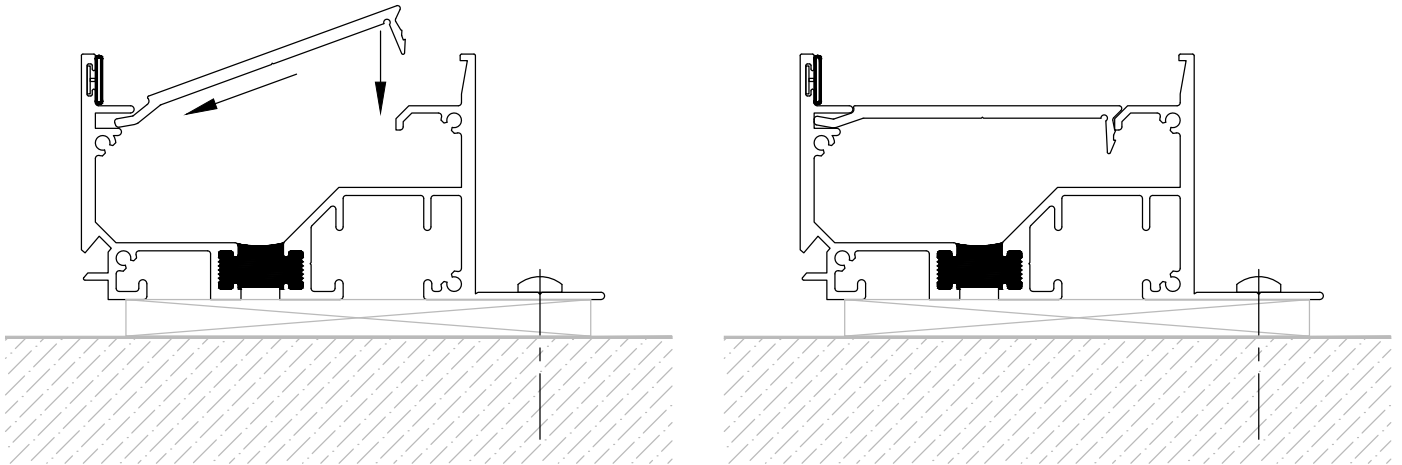

FI9

Attach the bottom (Sill) Angle to the T-Mullion with the supplied fasteners. If not already done, drill pilot holes into the T-Mullion where needed. Then apply to sealant to each end as shown below.

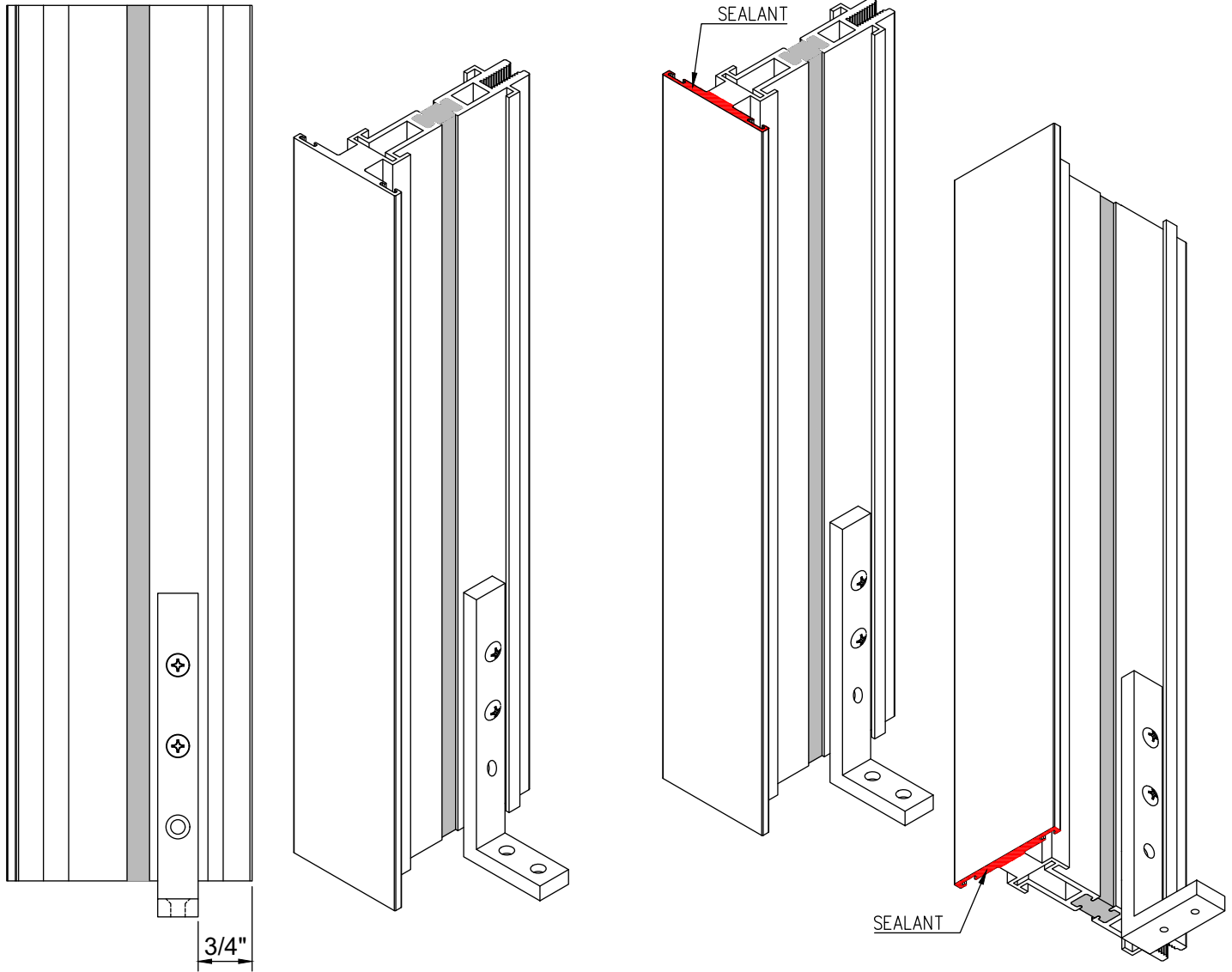

FI10

Install the T-Mullion into the Receptor Unit and fasten to the Anchor Plate with the supplied fasteners.
If not already done, drill pilot holes into the Anchor Plate where needed.
Tool sealant at top and bottom of the T-Mullion as needed.

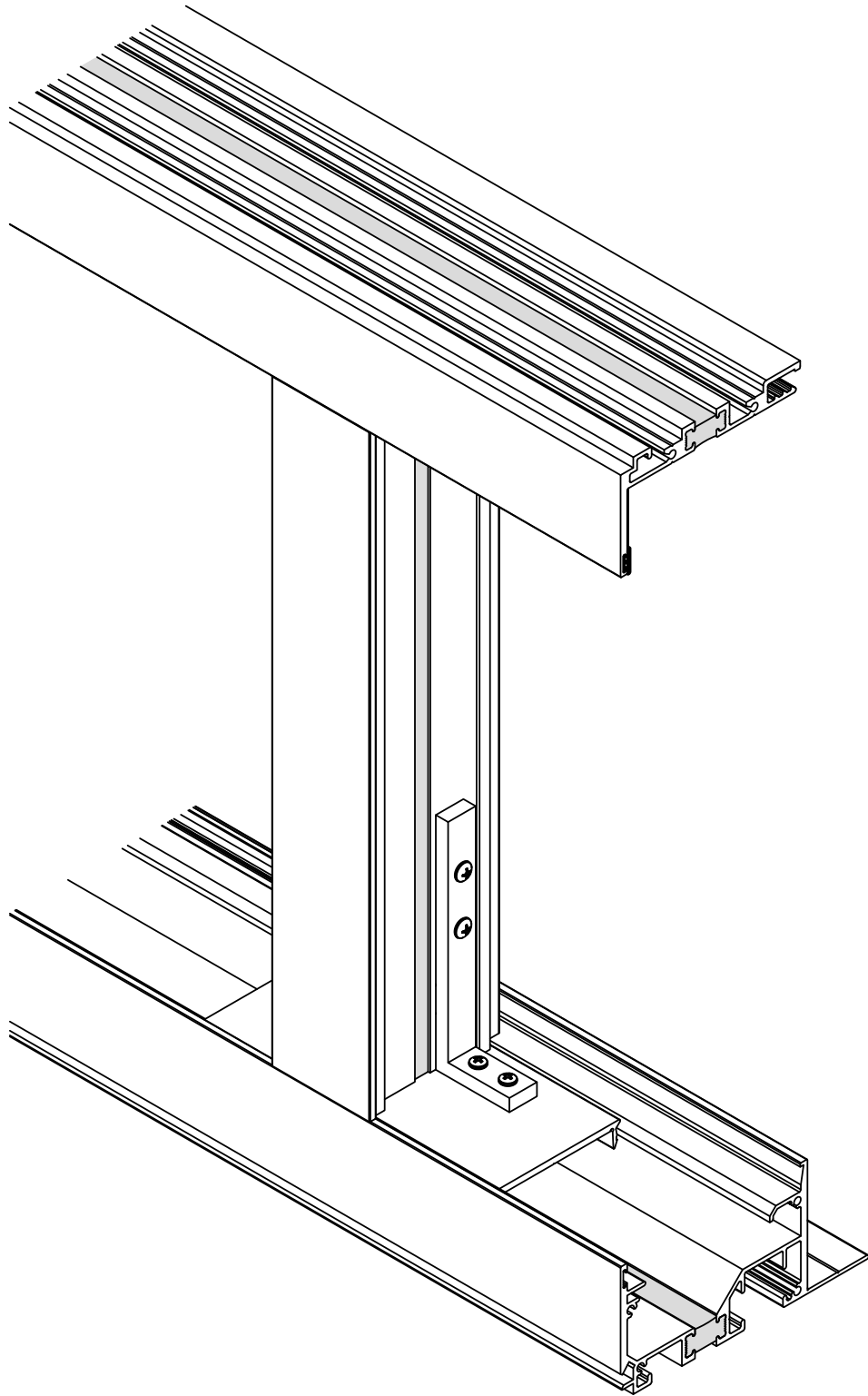

FI11

Square and level the T-Mullion and fasten to the Head Receptor with the supplied fasteners.
If not already done, drill pilot holes into the T-Mullion and Head Receptor.

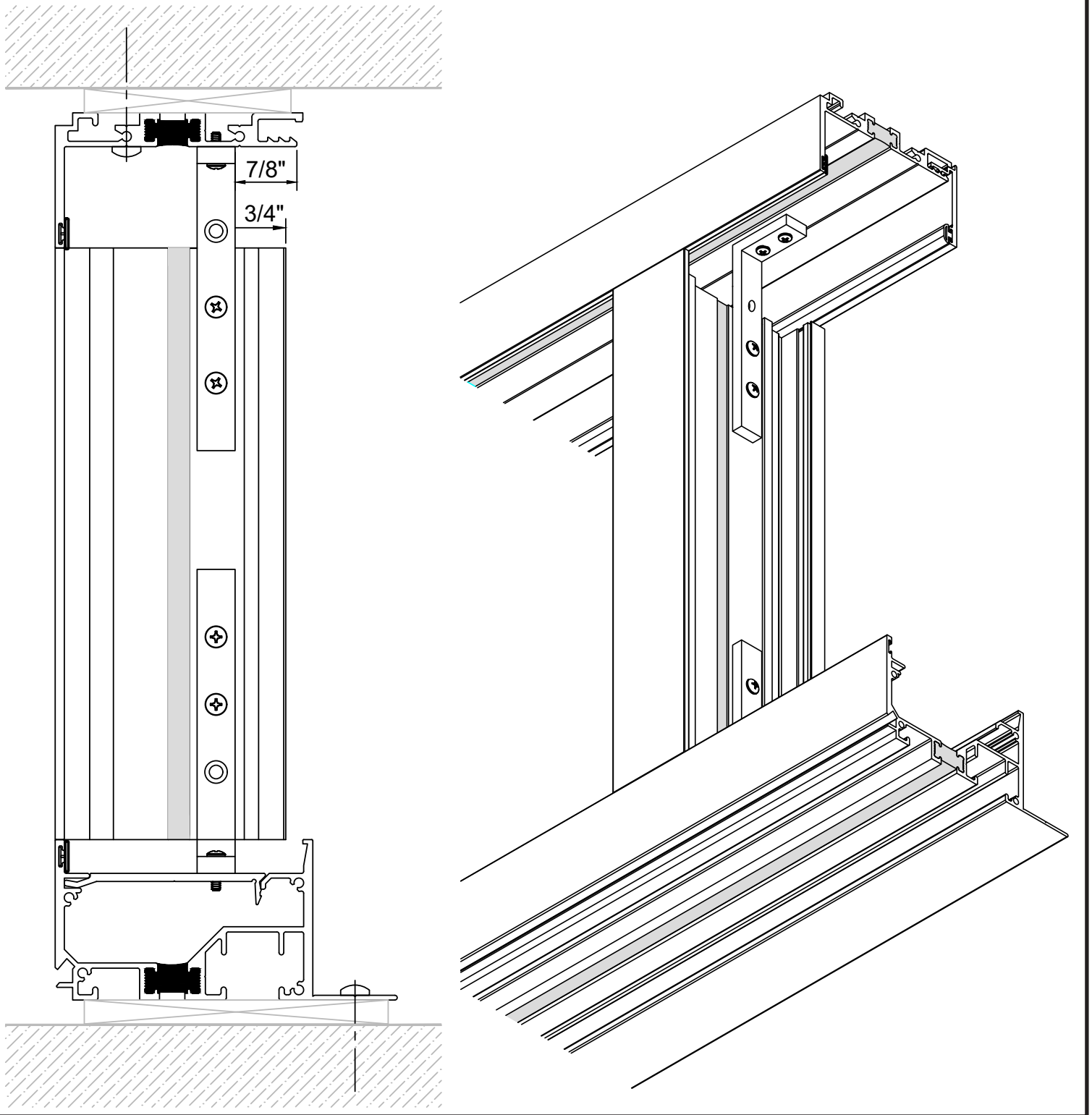

Repeat Instruction FI7 through FI10 where all T-Mullions are required.

FI12

Measure each jamb condition from bottom of Head Receptor to top Sill Receptor. Verify that the Jamb members are the correct size. Cut to length if needed. If not already done, drill holes into the perimeter of the Jamb Receptor as called out on the Shop Drawings or the Structural Calculations. Before placing the Jamb Receptor in place, apply sealant to the ends as shown. Install the Jamb Receptor into the opening. Use plastic shims to ensure it is plumb and level, and tool sealant as needed.

(DO NOT PLACE RECEPTOR UNIT DIRECTLY ON THE BUILDING STRUCTURE WITHOUT SHIMS).

When level, drill pilot holes in the surrounding conditions and fill with sealant.

Apply sealant at the sill end of the Jamb Member where shown below.

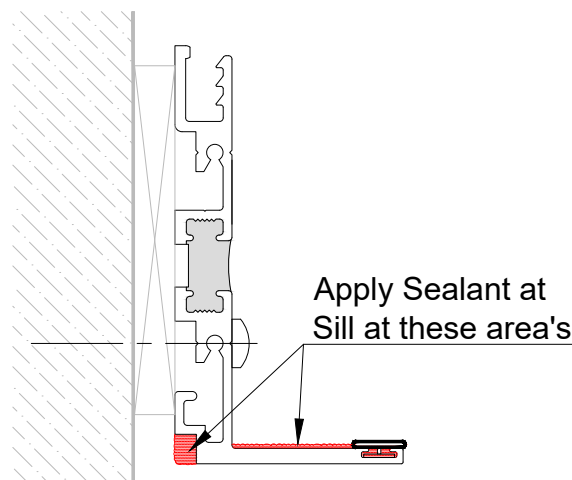
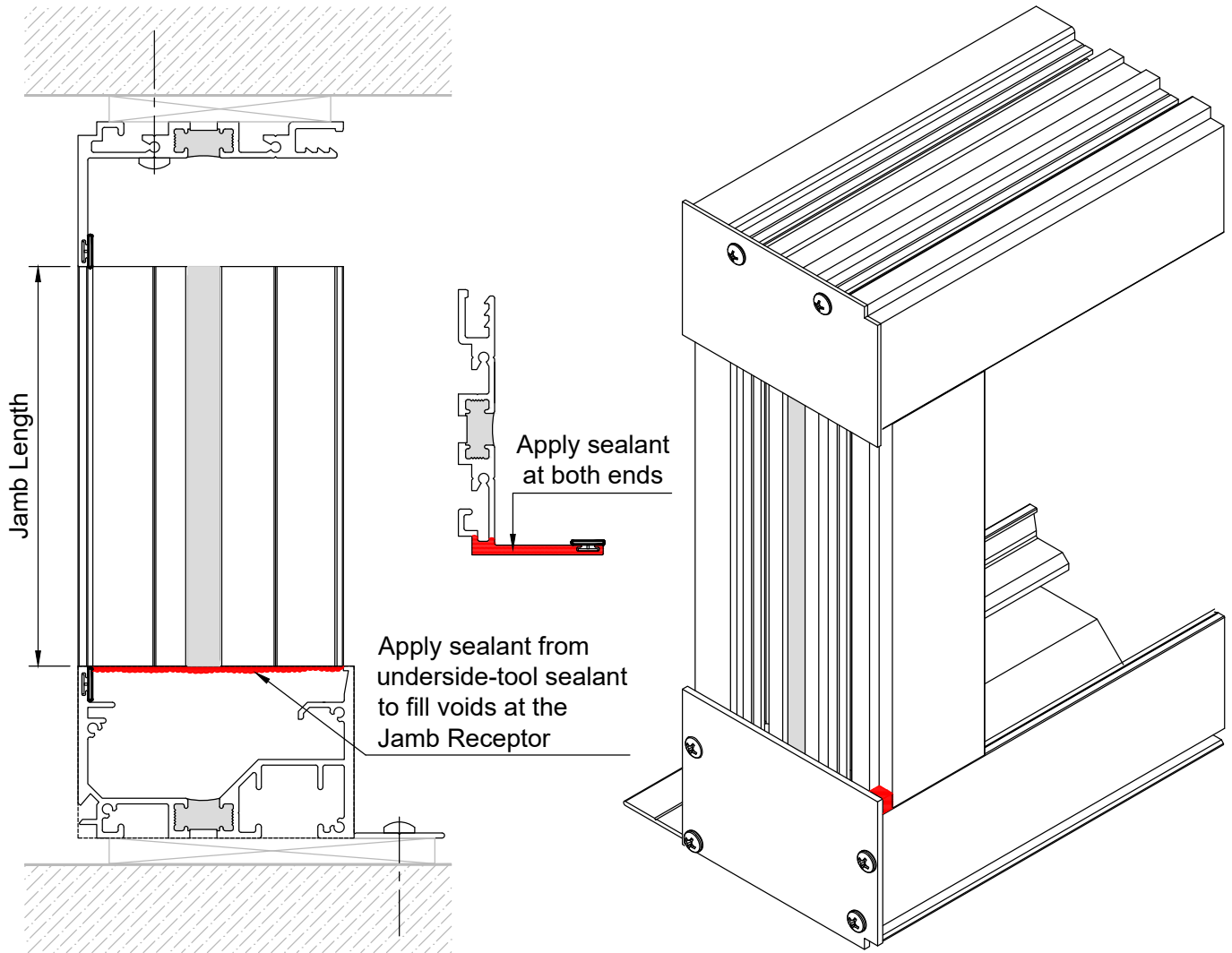

Fastener locations are for reference only. Locations should be located where shown on the Shop Drawings or the Structural Calculations, and should be inserted into a structural part of the surrounding conditions.

WI1

NOTE:

Window installation instructions are based on two or more Window Units.

If only one Window Unit is required, skip instruction WI3 and proceed to instruction WI4.

Before installing the Window Unit, apply sealant full height at the T-Mullion and across the Head, Jamb, and Sill Members as shown below. Sealant should be continuous, with jamb sealant marrying with head and sill sealant.

Install the 1st Window Unit into the Receptor Frame from the interior. Tilt the top of the unit in and lift the unit over the inside leg of the Sill Receptor. Push the Window Unit tight against the outside weathering.

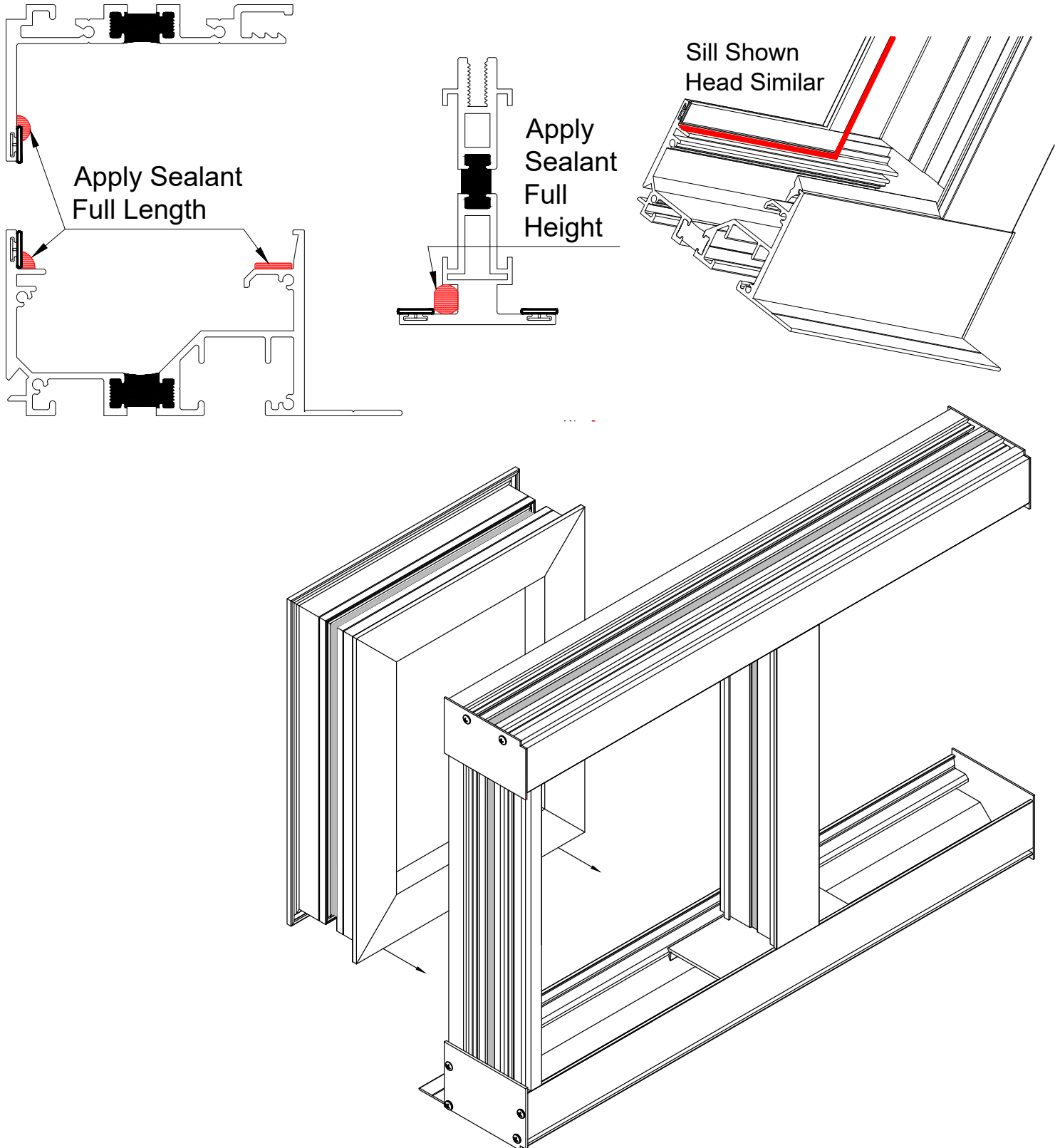

WI2

At the centerline of the Window Unit install a temporary 6" peice of Head Stop, and a 6" peice of Wedge Gasket at the sill.

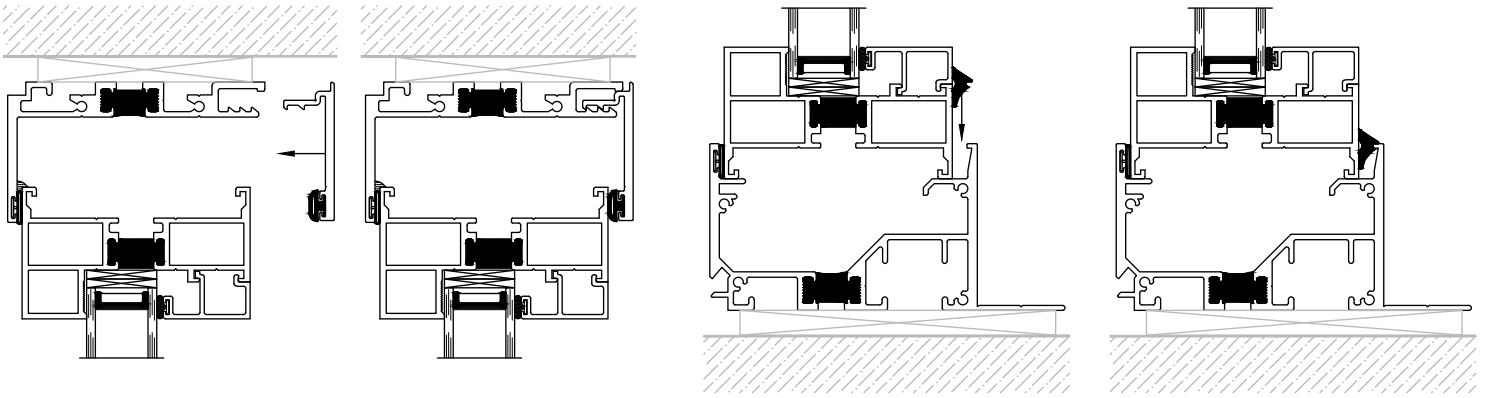

WI3

NOTE:

**Window installation instructions are based on two or more Window Units.
If only one Window Unit is required, skip instruction WI3 and proceed to instruction WI4.**
After installing the 1st Window Unit, continue to install the remaining units as directed in instructions WI1 and W2.

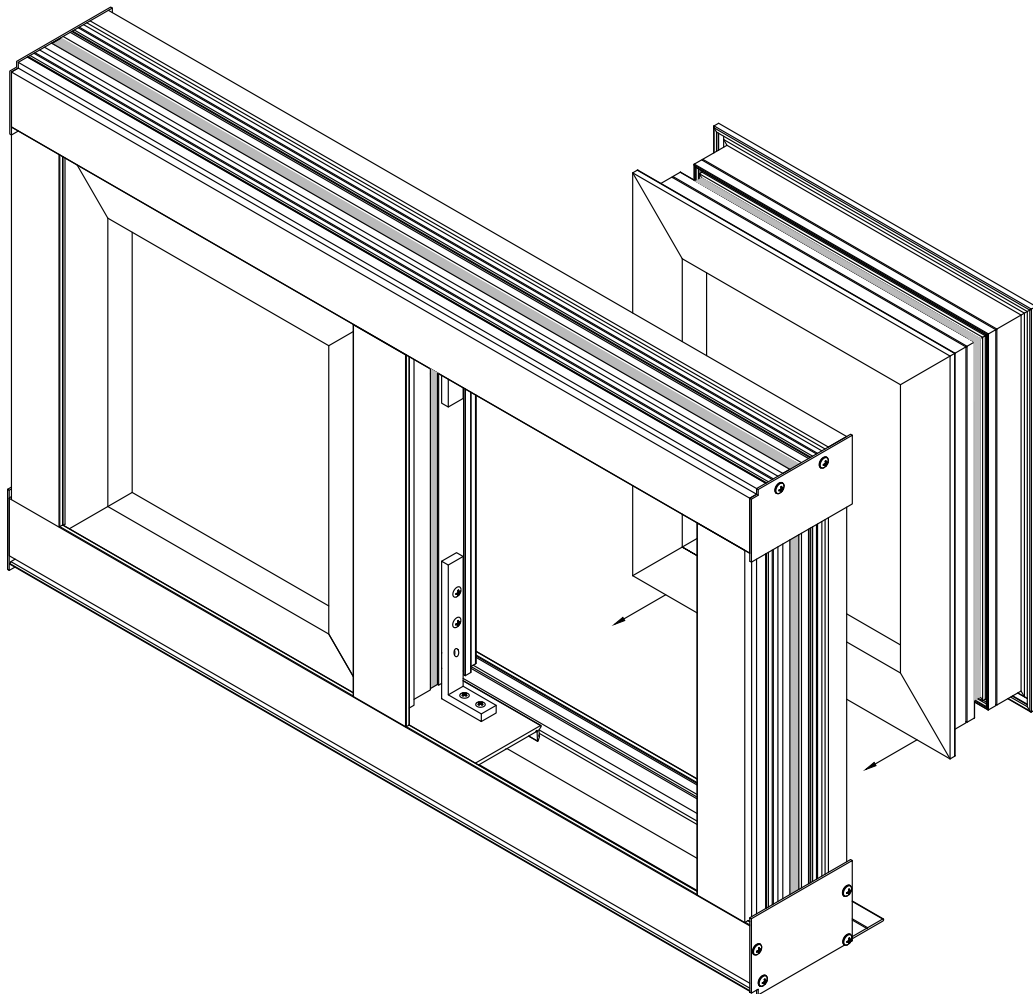

WI4

Measure and cut (if needed) the Head Stop. The length should be equal to the length of the Head Receptor.

Apply sealant to the Head End Dam where the Head Stop will contact it, and push Stop into place. After pushing the Head Stop in place, tool as needed. If the opening requires two Head Stops, they should be butted tight together in a different area than the splice joint. Apply sealant to the end of one of the Head Stops before pushing into place. Tool as needed.

Measure and cut (if needed) the Jamb Stops. The length should be equal to the distance between the Head Stop and Sill Receptor. Apply sealant to both ends of the Jamb Stops, and 6" up the snap pocket at the Jamb Receptor. Push into place. After pushing the Jamb Stop in place, tool as needed.

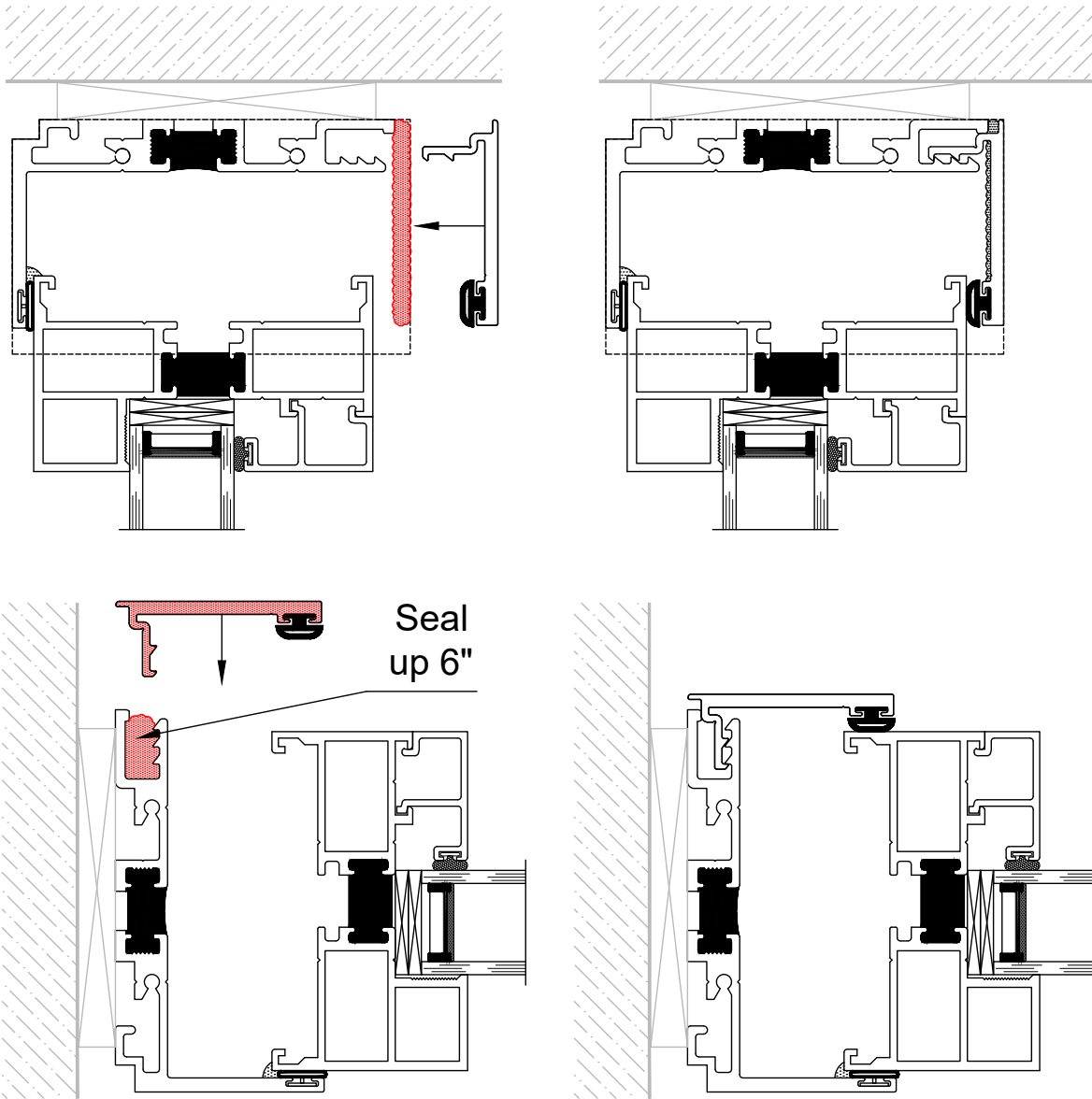

WI5

Measure and cut (if needed) the T-Mullion Pressure Plate and Cover. The length should be equal to the vertical opening between the Head Stop and the Sill Receptor minus 1/16".

Fill the voids between the T-Mullion and the Window Frames with backer rod and apply sealant in the void.

Apply sealant full height at the window to T-Mullion area, and 6" from the top and bottom at the T-Mullion raceway as shown below.

Apply the Pressure Plate with the supplied fasteners, 3" from the ends and 12" O.C.

Make sure the fasteners are installed straight, and do not over-tighten the fasteners to ensure a uniform seal of the weathering to the mullions.

After the Pressure Plates are in place, snap the on cover.

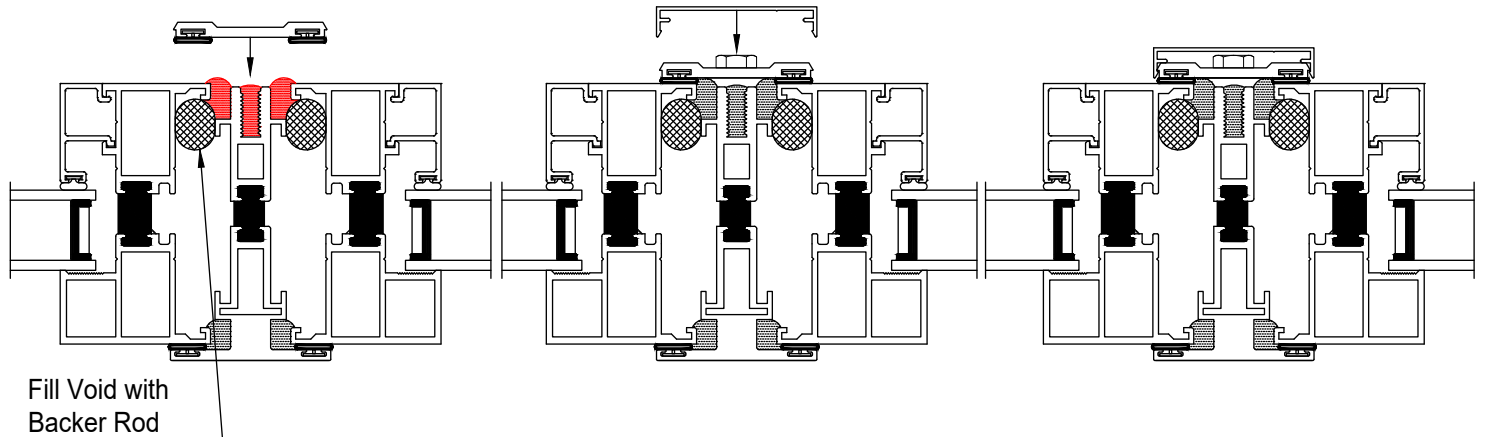

WI6

Measure and cut the wedge Gasket for the Sill Receptor. The length should be 1" longer than the opening from the Jamb Stop to Jamb Stop, or Jamb Stop to T-Mullion Cover.

Remove the temporary Wedge Gasket at the Sill Receptor, and press/crowd the final Wedge Gasket into place.

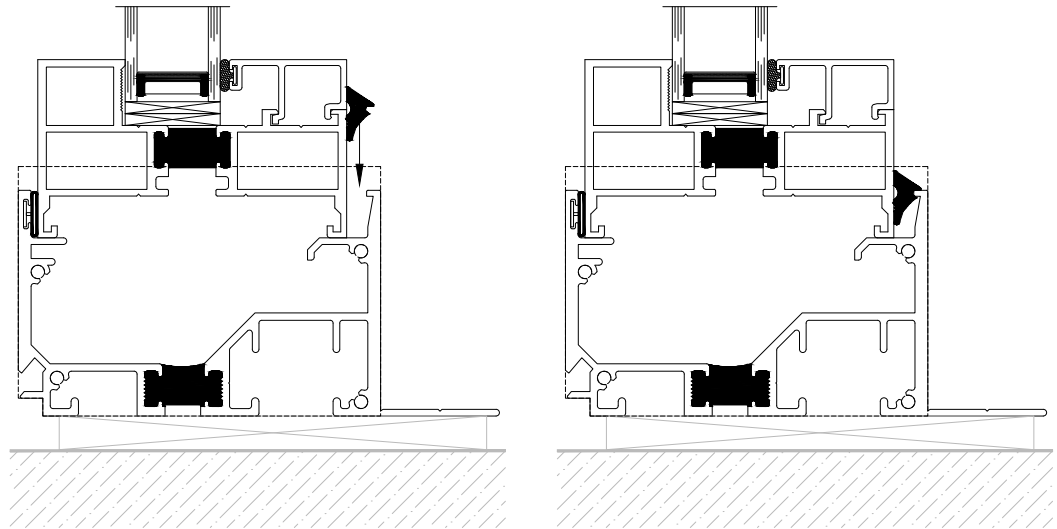

Proceed to Sealing Instructions on page 21

With Liquid Barrier Application (LBA) (Page 20)

LB1

After the initial LBA has been applied, from the interior measure and verify the size of the rough opening. The rough opening should be a 3/4" wider and 3/4" taller than the Window Unit, unless otherwise noted on the shop drawings. Verify the rough opening is flat, plumb, level, and square. Take diagonal measurements to check for square. The sill plate beneath the unit must be level for proper unit operation.

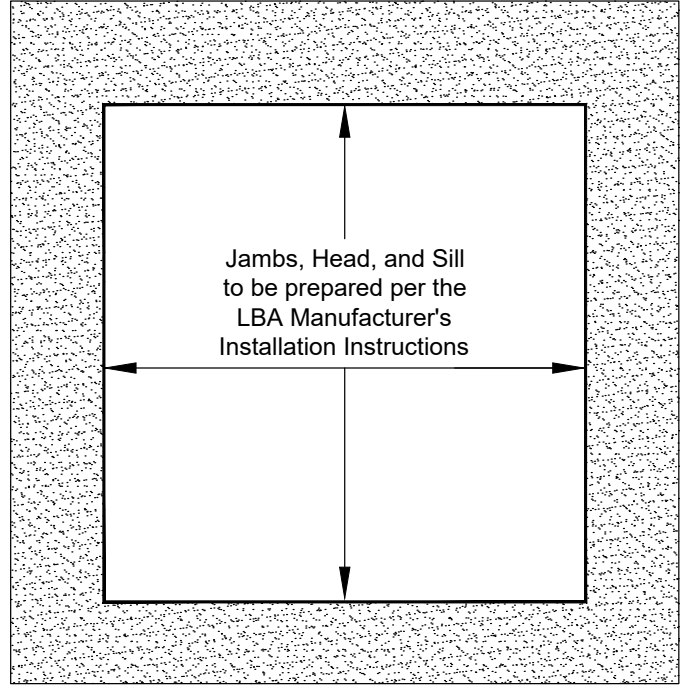
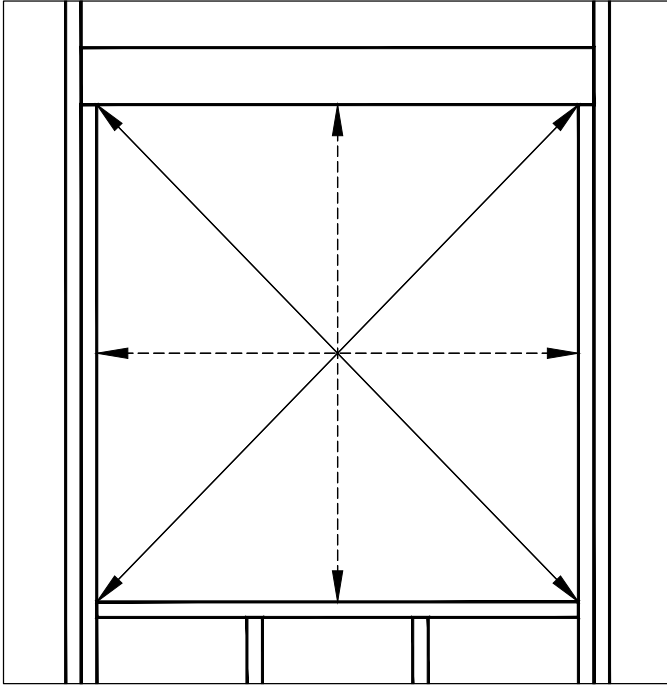

LB2

Refer to instructions FI1 (Page 7) to FI12 (Page 15) and WI1 (Page 16) to WI5 (Page 19) for the remainder of the Liquid Barrier installation.

SI1

Refer to the Shop Drawings if additional flashing or other material is required. After exterior building construction is completed, install back rod, then apply a continuous bead of sealant around entire perimeter of the exterior receptor frame and tool as needed.

Note:
Installer to verify that Sealant being used is compatible with Quaker window frame and the surrounding building construction materials.

Note:
Please inform the exterior facade installer that they must maintain a minimum 1/4" gap between the facade material and the Receptor Unit, and that the facade material should never come in contact with the Window Unit.

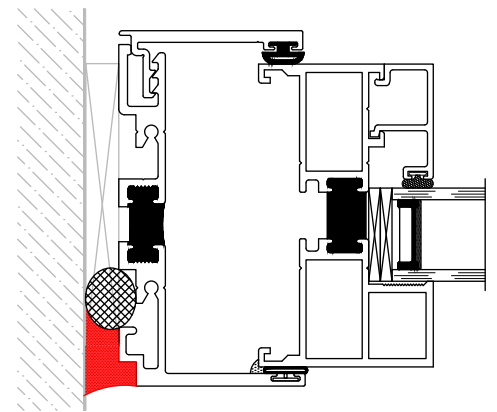
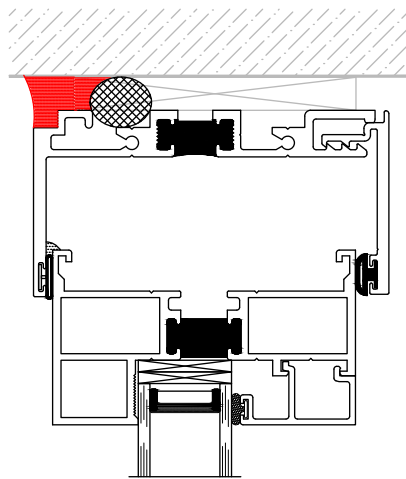
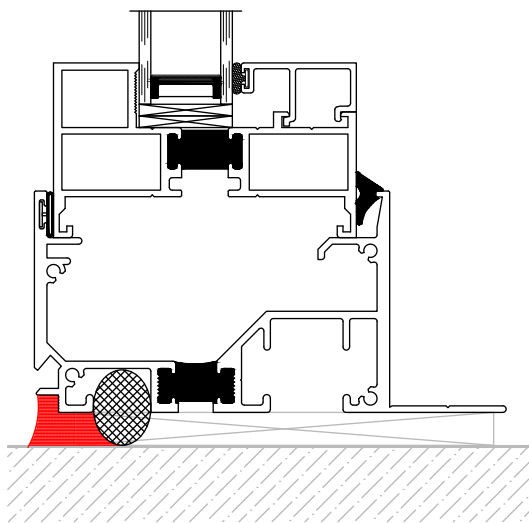
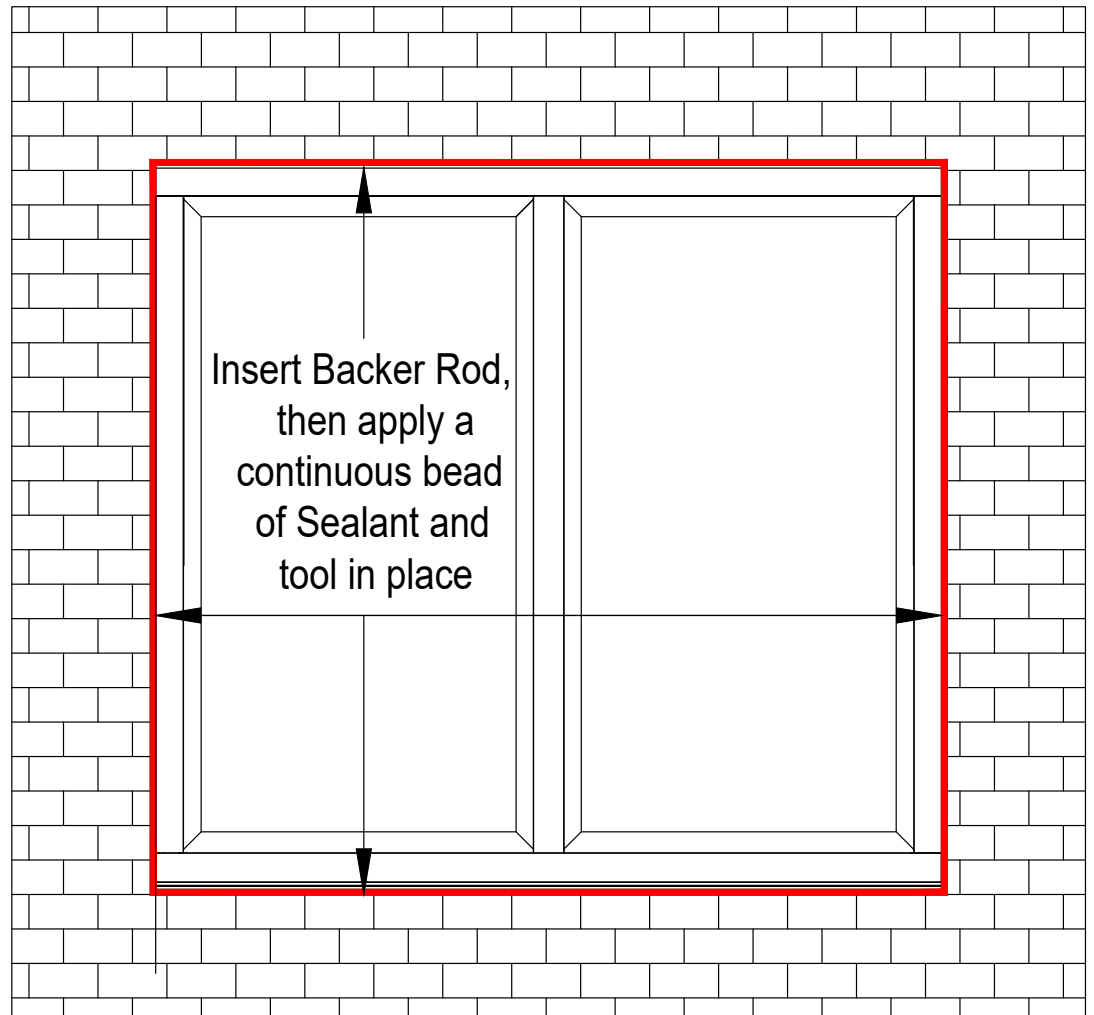

At the interior head and jambs, insert insulation between the frame and the building conditions (no insulation at the sill).

Install back rod, then apply a continuous bead of sealant around entire perimeter of the interior receptor frame and tool as needed.

Note:
Installer to verify that Sealant being used is compatible with Quaker window frame and the surrounding building construction materials.

