



H650

HISTORICAL ALUMINUM SERIES

Single Hung | Fixed | Fixed Simulated Hung









 **Product Material**
Aluminum

 **Frame Depth**
4 1/8"

 **Rating**
Single Hung: up to AW75
Fixed: up to AW90

Temple Detroit Hotel
(formerly Standard Insurance Bldg.)
Detroit, MI
Developers: Temple Group Holdings
Architect: McIntosh Poris Associates
Contractor: Rockford Const. Co.
Dealer: Blackberry Systems



 Design Pressure Single Hung: up to 75 Fixed: up to 90	 U-Value* Single Hung: .28 - .43 Fixed: .22 - .43
 Air Infiltration Single Hung: <0.30 Fixed: <0.10	 SHGC* Single Hung: .15 - .32 Fixed: .16 - .36
 Water Resistance Single Hung: 12 Fixed: up to 15	 CR* Single Hung: 42-60 Fixed: 44-70
 OITC^x Single Hung: 24-31 Fixed:	 STC^x Single Hung: 31-35 Fixed:
<small>*-Ranges based on multiple Low-E/Argon I.G. combinations <small>x-Ranges based on multiple I.G. combinations</small> </small>	

FEATURES:

- ▶ Historically-correct bevel exterior frame
- ▶ Architectural grade aluminum frame
- ▶ Thermally-broken frame and sash with pour-and-debridge technology
- ▶ No fin main frame for retro-fit purposes
- ▶ Alternative model with Nail fin (H655 Series)
- ▶ 1" insulating glass
- ▶ Heavy-duty Class 5 balancers
- ▶ Auto lock sill
- ▶ Standard High-Performance 2604 Powder Paint Finish (an FGIA Specification)
- ▶ Optional Upgrade to 2605 Powder Paint Finish (an FGIA Specification)
- ▶ 30+ "Quick-Pick" colors, with unlimited custom colors available

www.QuakerCommercialWindows.com

Information listed is deemed accurate as of date shown. Quaker Windows reserves the right to change or discontinue any product, feature or option without notice.

March, 2026 V11



H650

HISTORICAL ALUMINUM SERIES

Single Hung (AW60)

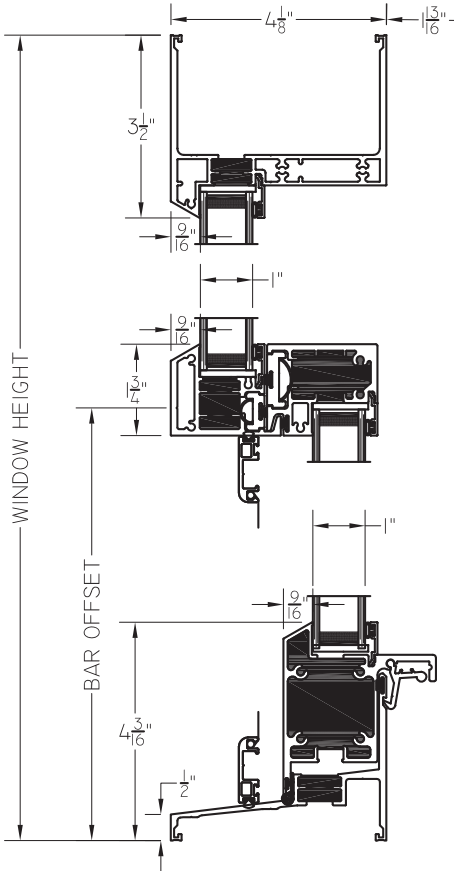

Fixed Offset Hung

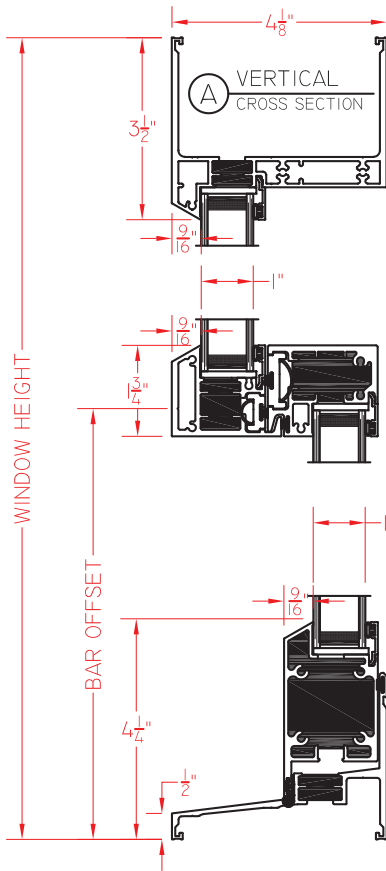

Fixed

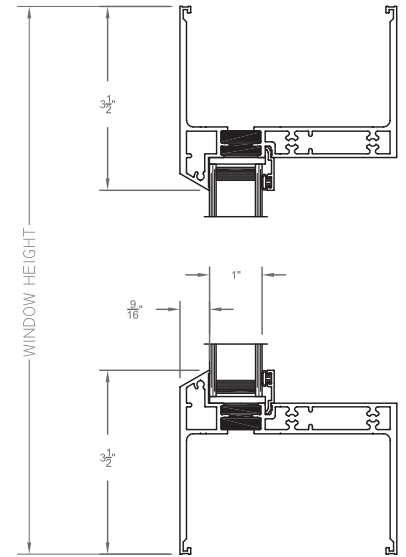

All ratings listed are NAFS certified.

The Lofts at Centennial Yards
 (formerly Southern Railways Building)
 Atlanta, GA
 Developers: CIM Group
 Architect: Surber Barber Choate + Hertlein
 Contractor: Whiting Turner Contracting
 Dealer: LJW Sales



QuakerCommercialWindows.com
 1-800-347-0438
 Commercial@quakerwindows.com