



# V200

COMMERCIAL VINYL SERIES

## Casement | Project-Out | Fixed









 **Product Material**  
uPVC Vinyl

 **Frame Depth**  
3 1/4"

 **Rating**  
Casement: R40  
Project-Out: R40  
Fixed: R40 / CW50

LH44 Apartments  
Minneapolis, MN  
Developer: 2620 at Harriett, LLC  
Contractor: Greiner Construction  
Architect: Tushie Montgomery



 <b>Design Pressure</b> Casement: 40 Project-Out: 40 Fixed: Up to 50	 <b>U-Value*</b> Casement: .24 - .46 Project-Out: .25 - .46 Fixed: .22 - .49
 <b>Air Infiltration</b> Casement: <.30 Project-Out: <.30 Fixed: <.10	 <b>SHGC*</b> Casement: .10 - .52 Project-Out: .10 - .52 Fixed: .11 - .62
 <b>Water Resistance</b> Casement: 6.06 Project-Out: 6.06 Fixed: up to 7.5	 <b>CR*</b> Casement: 31 - 61 Project-Out: 30 - 61 Fixed: 31 - 62
 <b>OITC<sup>x</sup></b> Casement: Contact Quaker Project-Out: Contact Quaker Fixed: Contact Quaker	 <b>STC<sup>x</sup></b> Casement: Contact Quaker Project-Out: Contact Quaker Fixed: Contact Quaker
<p>*-Ranges based on multiple Low-E/Argon I.G. combinations x-Ranges based on multiple I.G. combinations</p>	

## FEATURES:

- ▶ Versatile uPVC vinyl window series with built-in budgetary advantages
- ▶ 3/4" insulating glass on all models except Fixed Direct Set (1")
- ▶ Mitered and welded corners
- ▶ Integral nail fin
- ▶ Metal reinforcements in pivotal areas for additional strength
- ▶ Numerous mull systems for multi-unit combos
- ▶ Roto, fold-down hardware on Casement and Project-Out models
- ▶ White or Sandstone vinyl
- ▶ Optional painted exterior (meets FGIA 615 finish)
- ▶ Textured laminate options for exterior and interior
- ▶ Use up to 4 floors

[www.QuakerCommercialWindows.com](http://www.QuakerCommercialWindows.com)

Information listed is deemed accurate as of date shown. Quaker Windows reserves the right to change or discontinue any product, feature or option without notice.

May 2026, V5



# V200

COMMERCIAL VINYL SERIES

## Casement

Test size = 24" x 60"

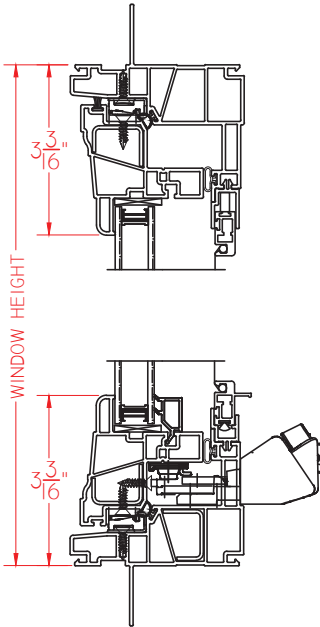

## Project-Out

Test size = 48" x 18"

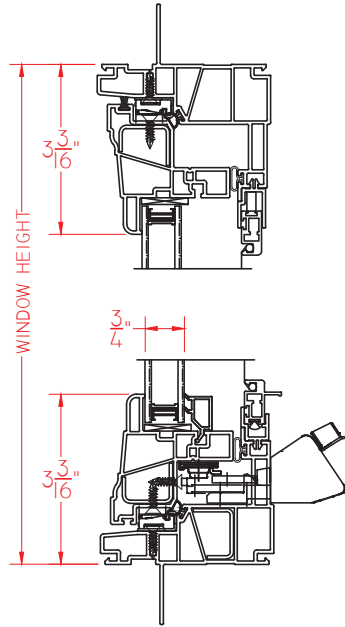

## Fixed

Test size = 48" x 48"

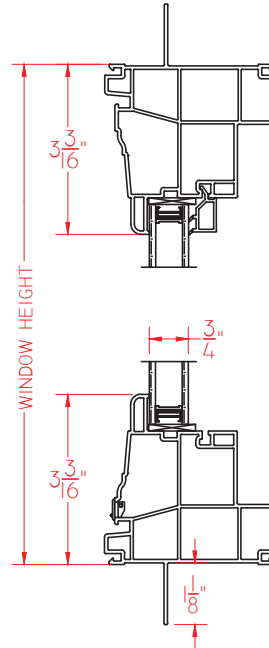

## Fixed Narrow

Test size = 60" x 60"

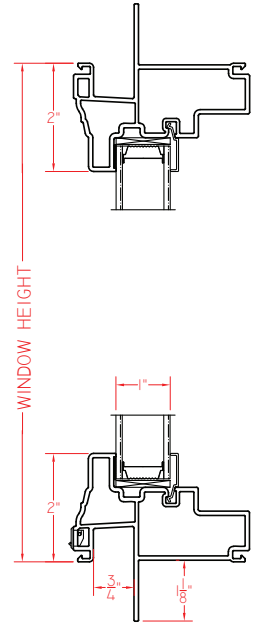

Founders Park  
Columbus, OH  
Developer: Thrive Companies  
Contractor: Daimler Group  
Dealer: Northern Window & Door Ltd.



[QuakerCommercialWindows.com](http://QuakerCommercialWindows.com)  
1-800-347-0438  
[Commercial@quakerwindows.com](mailto:Commercial@quakerwindows.com)